

# Accelerated Adult Learning (Basic Literacy) **Lesson 1-10** Flipchart



**ISEC** 

Improving Skills and  
Economic Opportunities  
for Cox's Bazar



# Accelerated Adult Learning - Basic Literacy

## Lesson 1

### Literacy and Livelihood Skills

Name the letter and its sound.

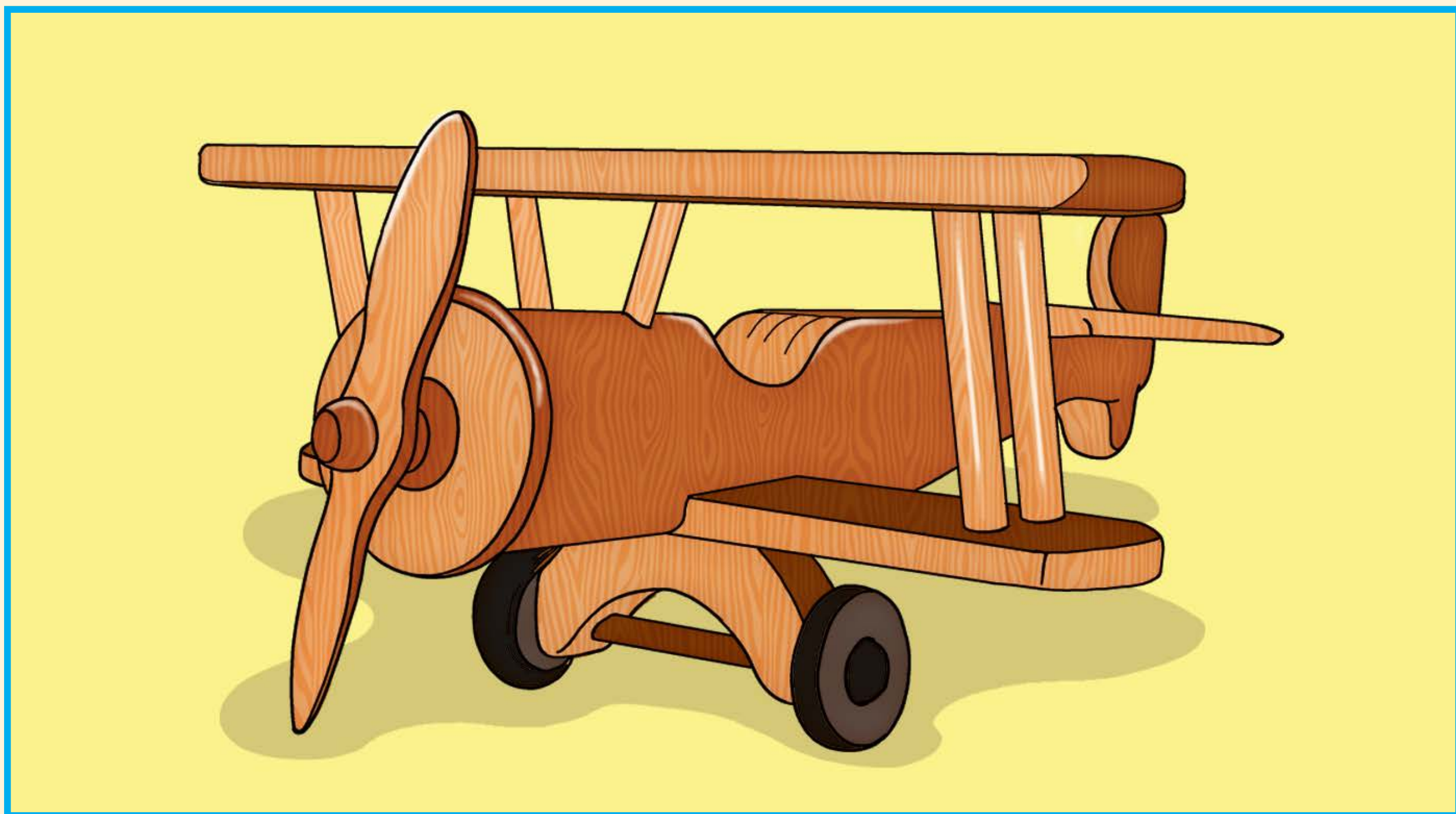

Father made an airplane.

airplane

a

A

Name the pictures and match them with the letters.

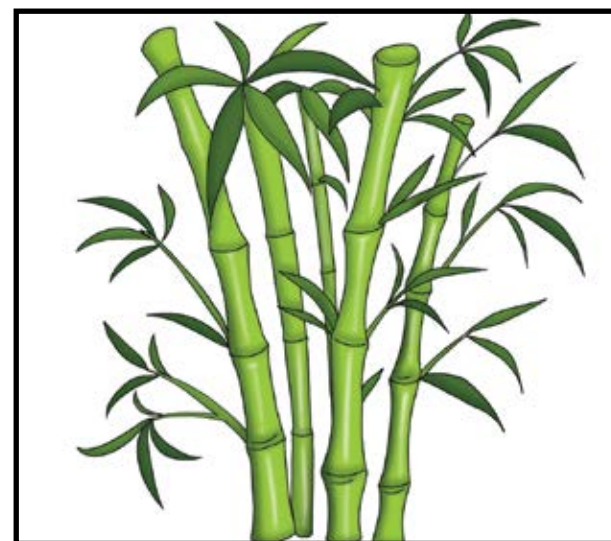
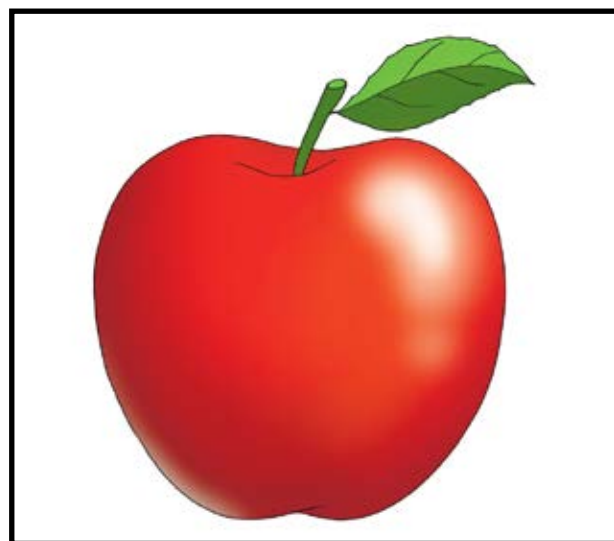
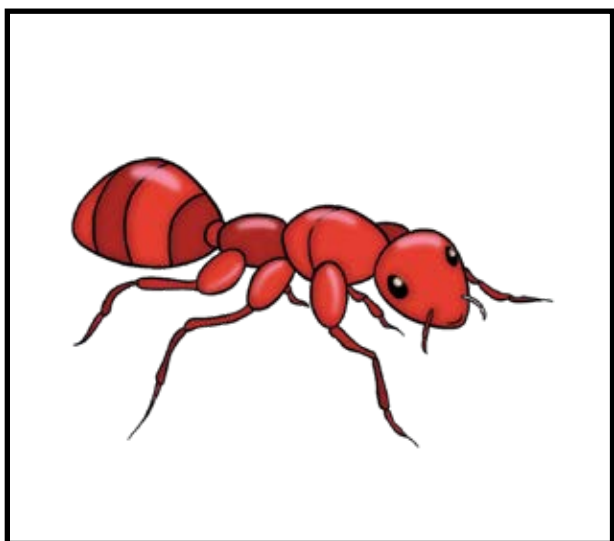

A

B

a

b

A

B



# Accelerated Adult Learning - Basic Literacy

## Lesson 2 Carpentry

Name the letter and its sound.

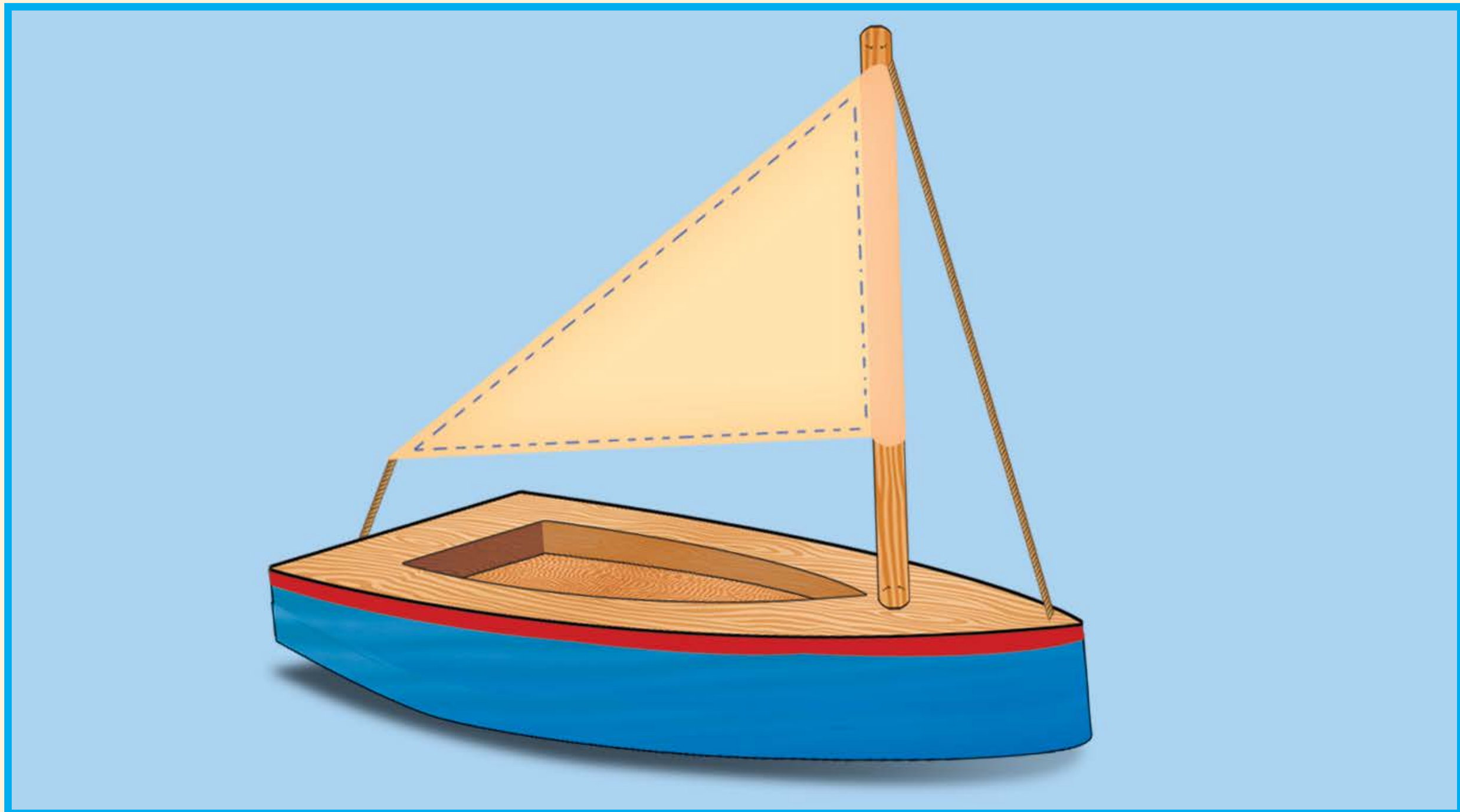

Mother made a **b**oat.

**b**oat  
b  
B

Name the pictures and match them with the letters.

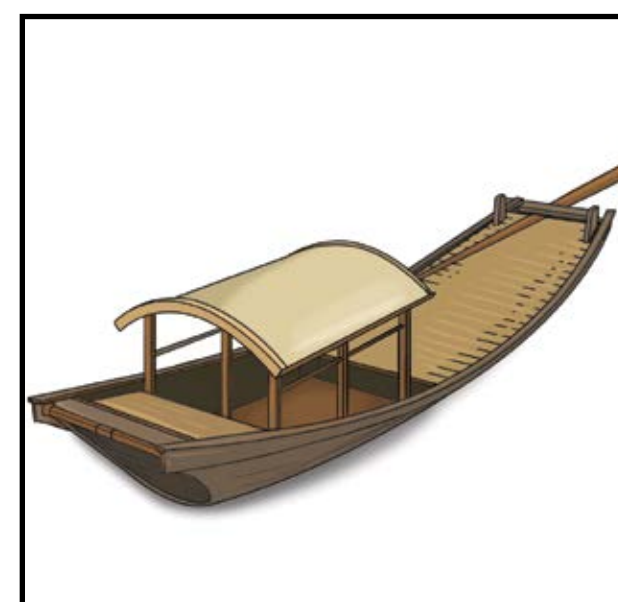
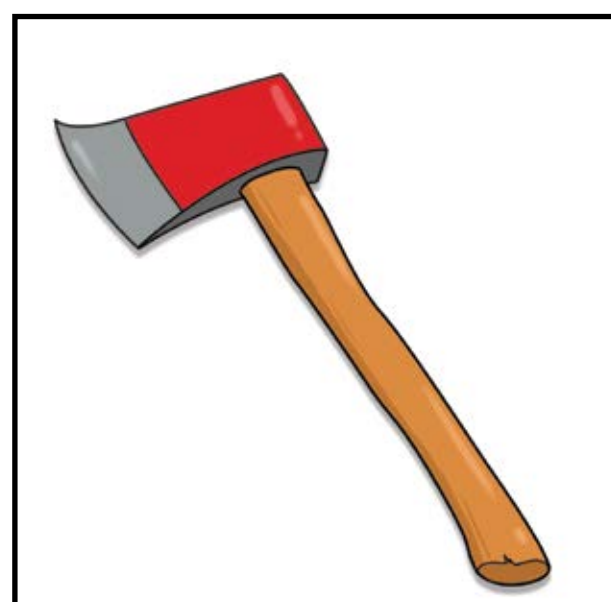
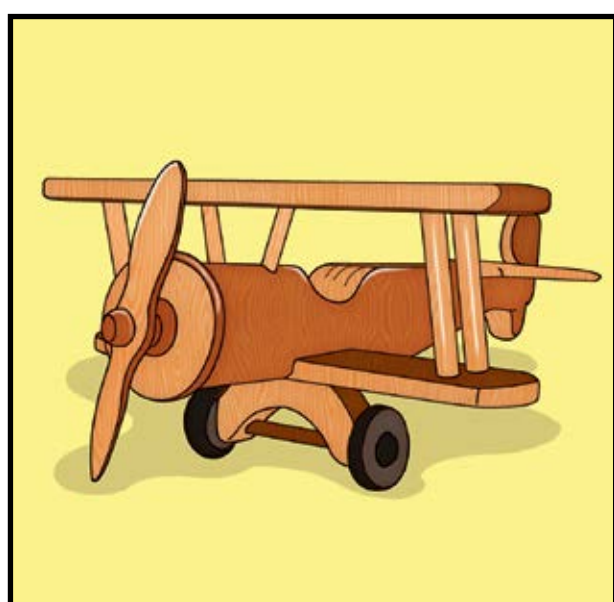

A      B      C      a      b      c



# Accelerated Adult Learning - Basic Literacy

## Lesson 3 Toys and Play

Name the letter and its sound.

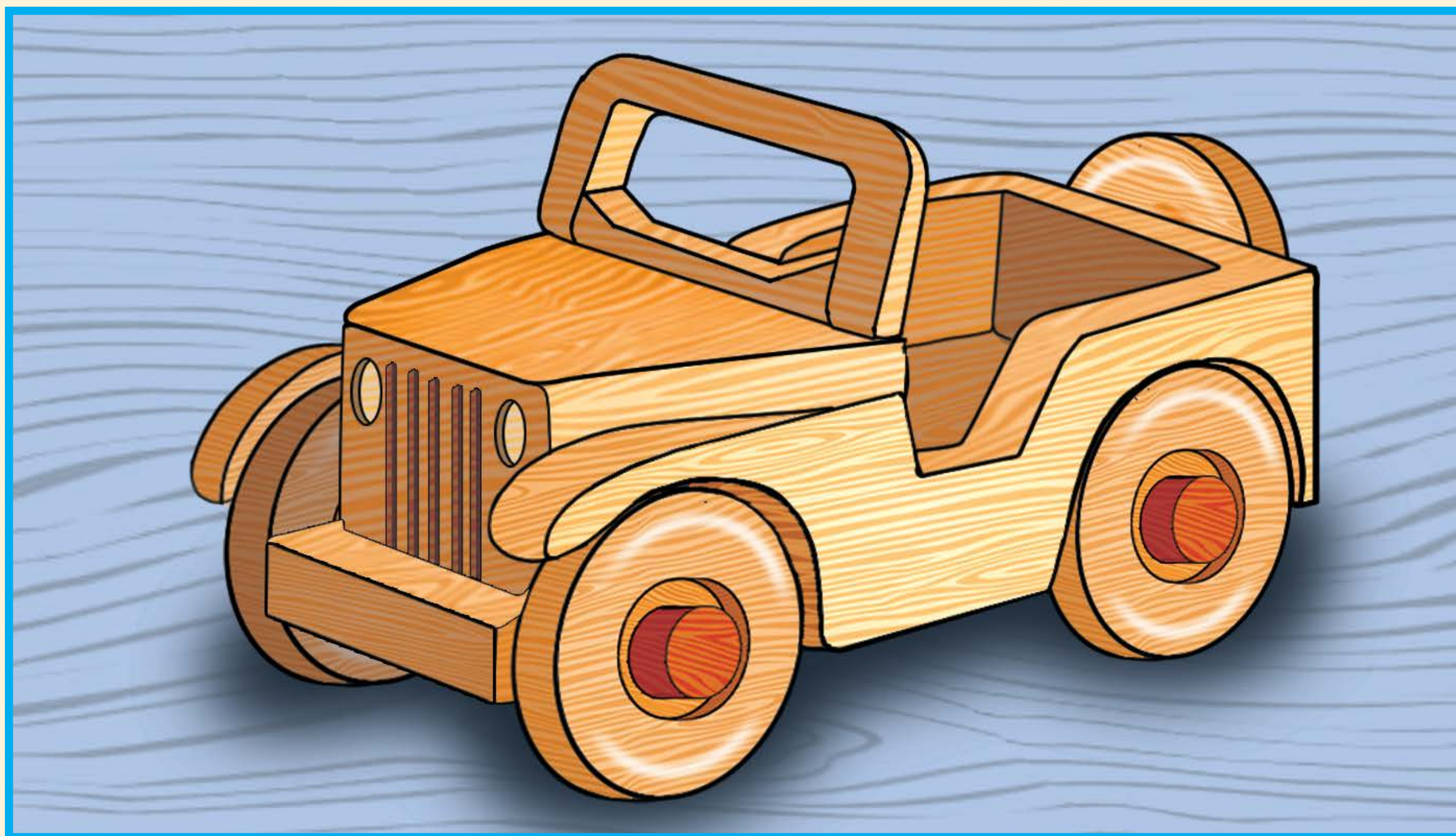

Sister made a **c**ar.

**c**ar

c

C

Name the pictures and match them with the letters.



B

C

D

b

c

d



# Accelerated Adult Learning - Basic Literacy

## Lesson 4 Self Employment

Name the letter and its sound.

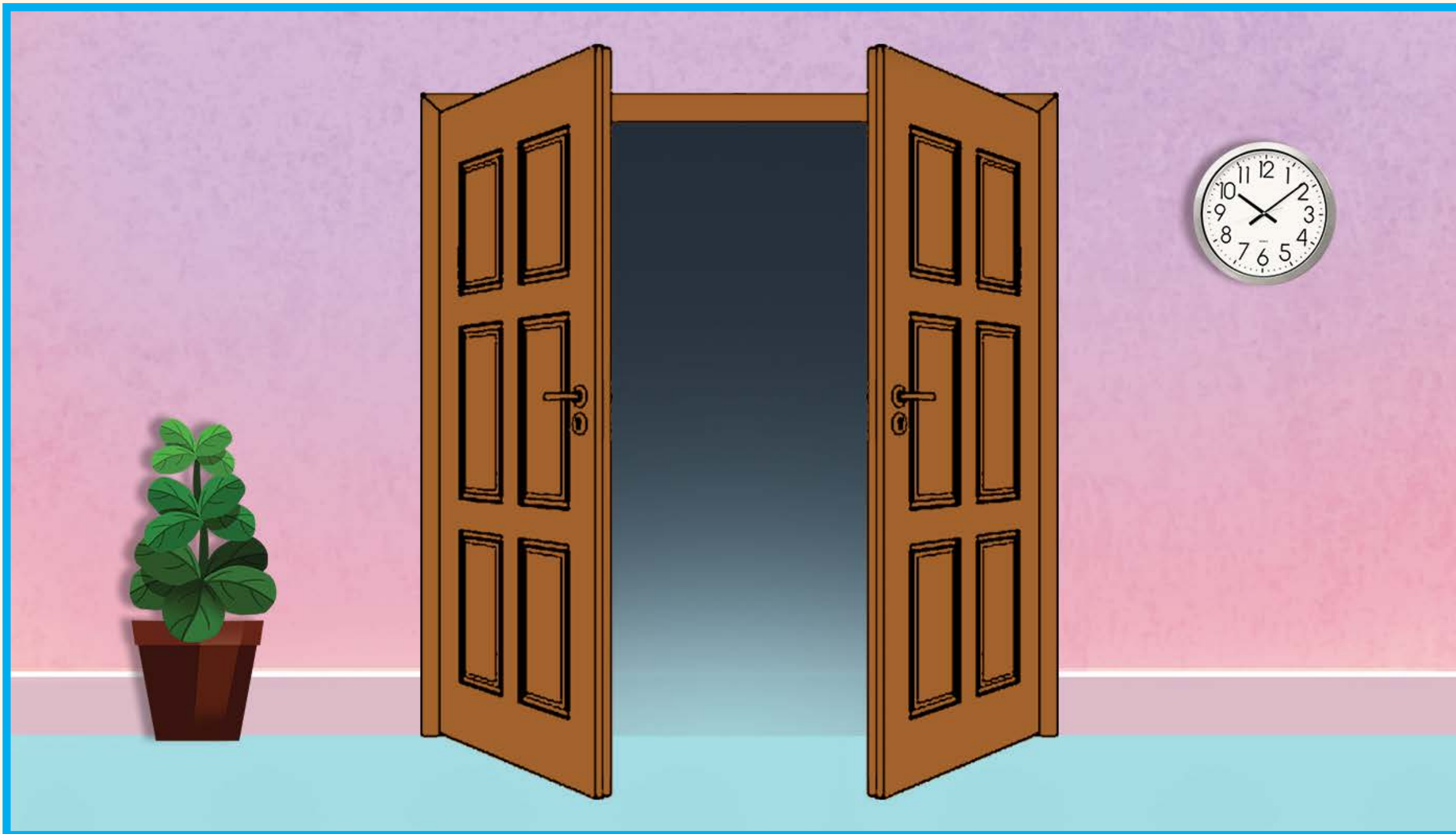

A carpenter made this **d**oor.

door  
d  
D

Name the pictures and match them with the letters.

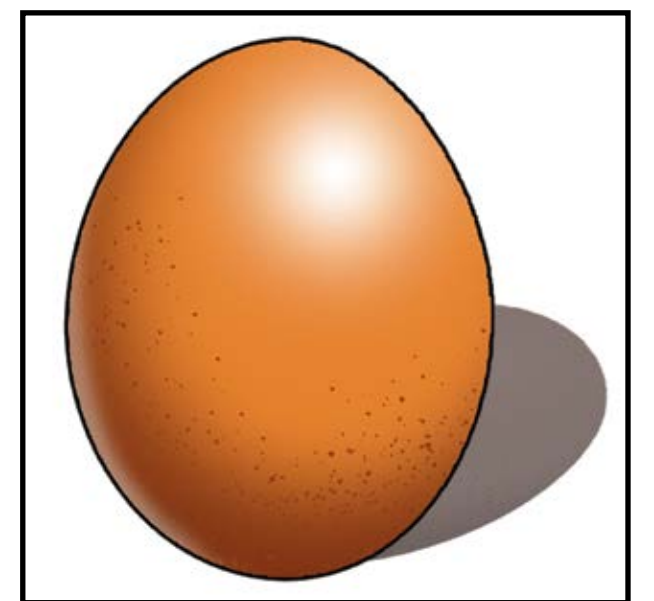
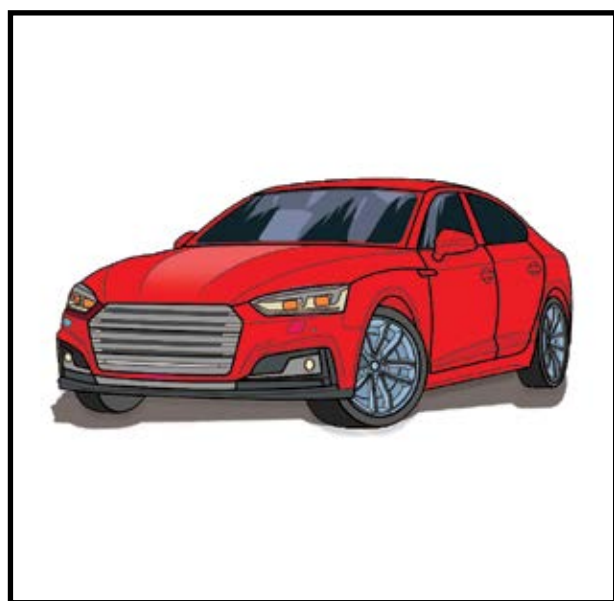

C

D

E

C

d

e



# Accelerated Adult Learning - Basic Literacy

## Lesson 5

### Eggs and Nutrition

Name the letter and its sound.



This is a quail **e**gg.

e  
e  
E

Name the pictures and match them with the letters.

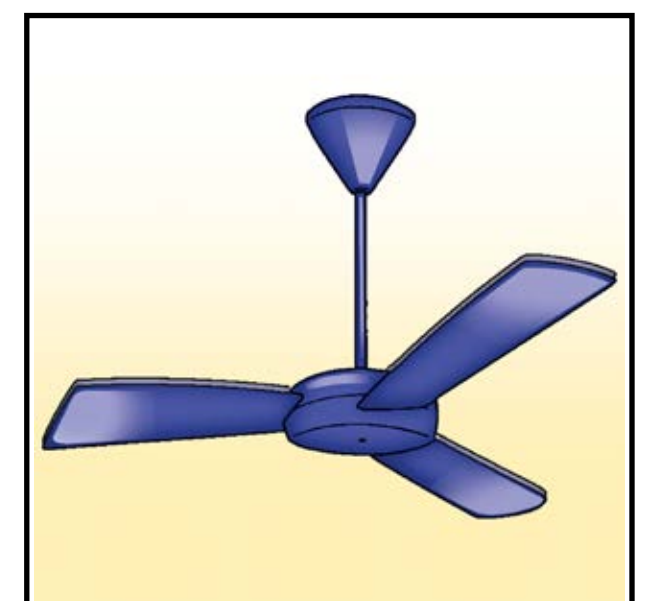
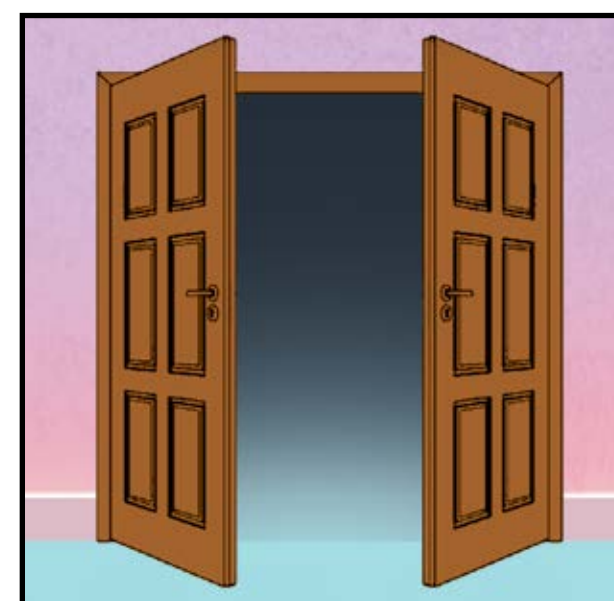
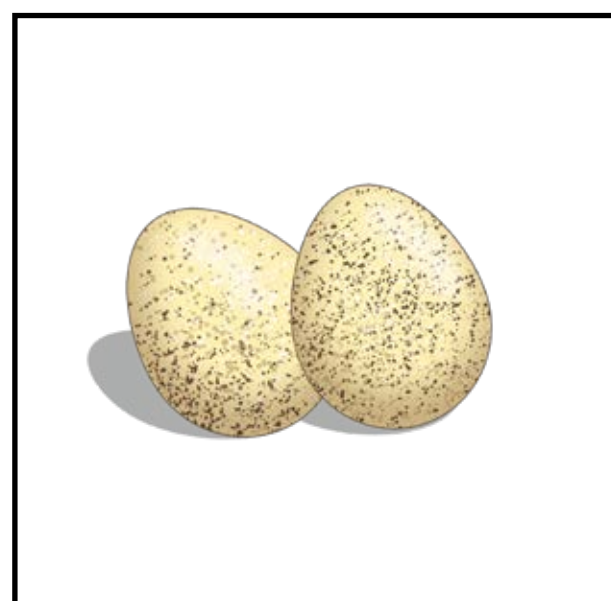
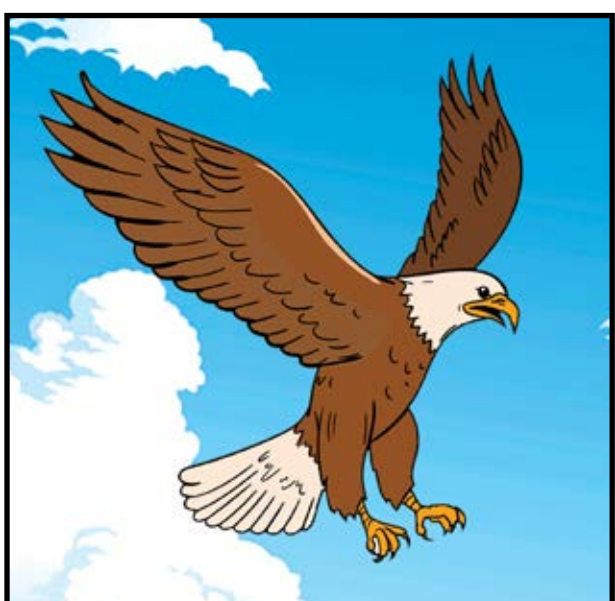

D

E

F

d

e

f



# Accelerated Adult Learning - Basic Literacy

## Lesson 6 Handicrafts

Name the letter and its sound.

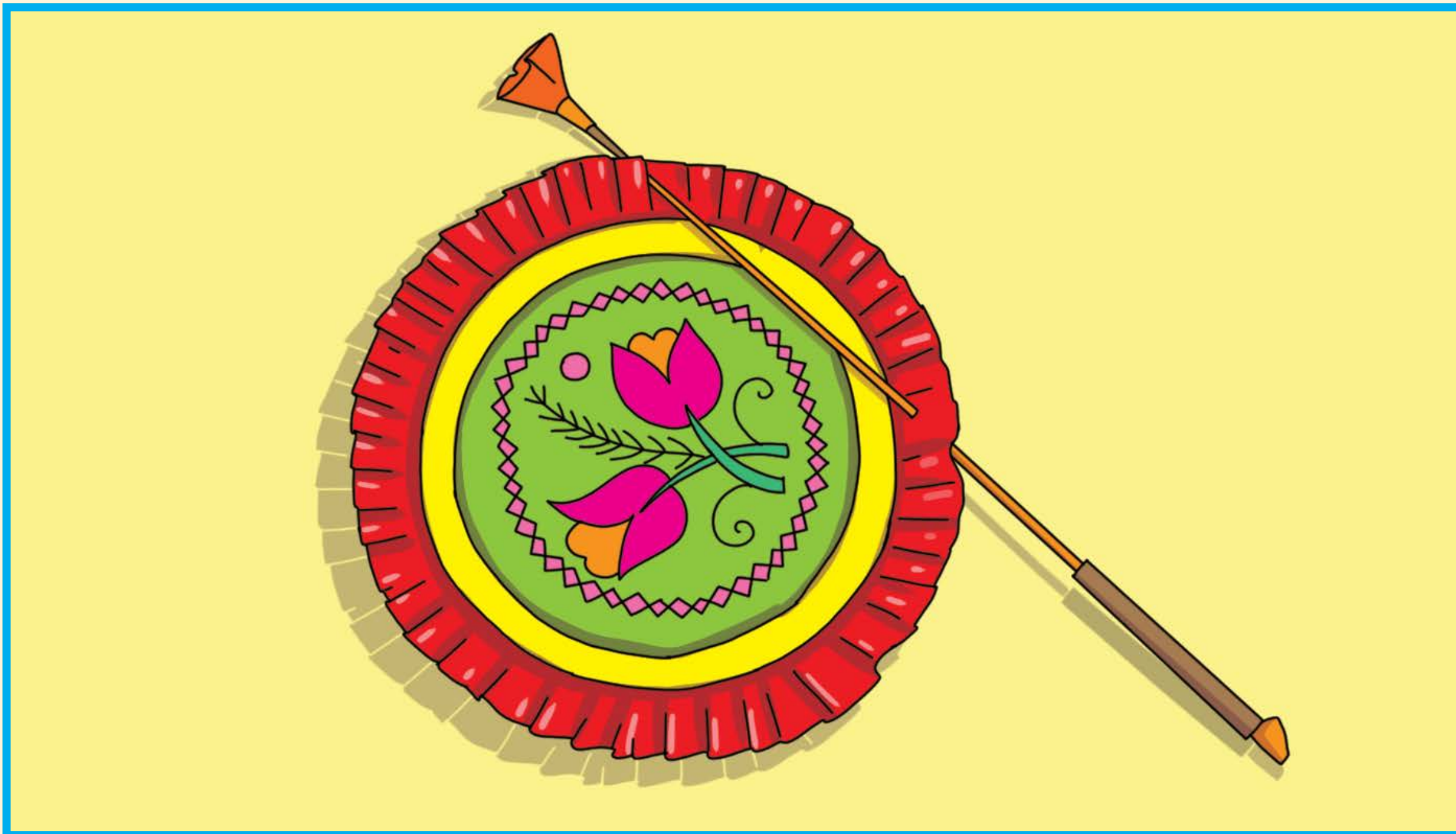

Asma made a fan.

fan

f

F

Name the pictures and match them with the letters.

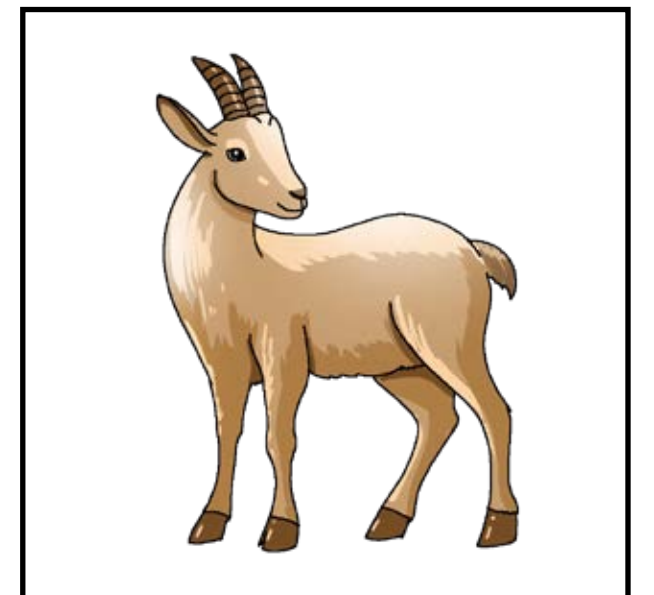
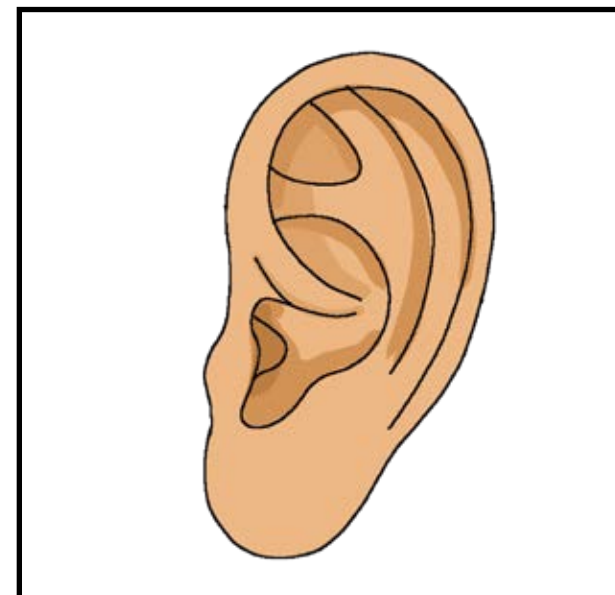
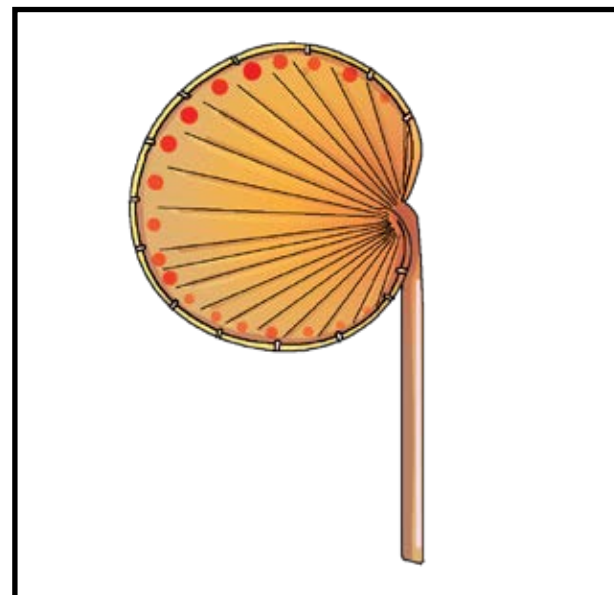
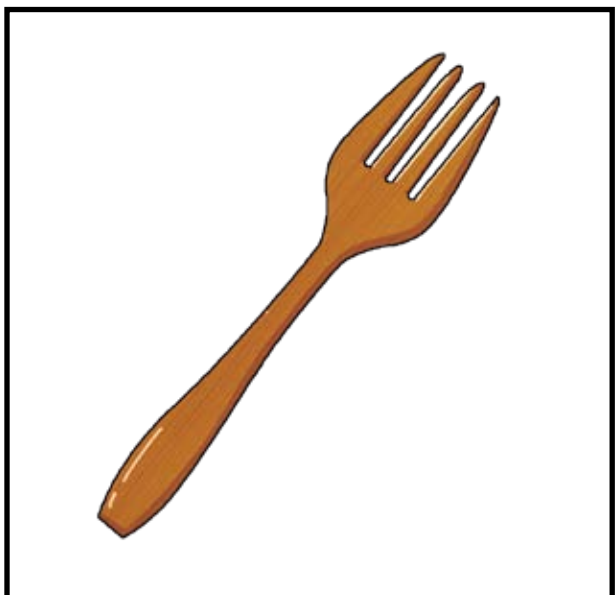

E

F

G

e

f

g



# Accelerated Adult Learning - Basic Literacy

## Lesson 7

### Milk

Name the letter and its sound.

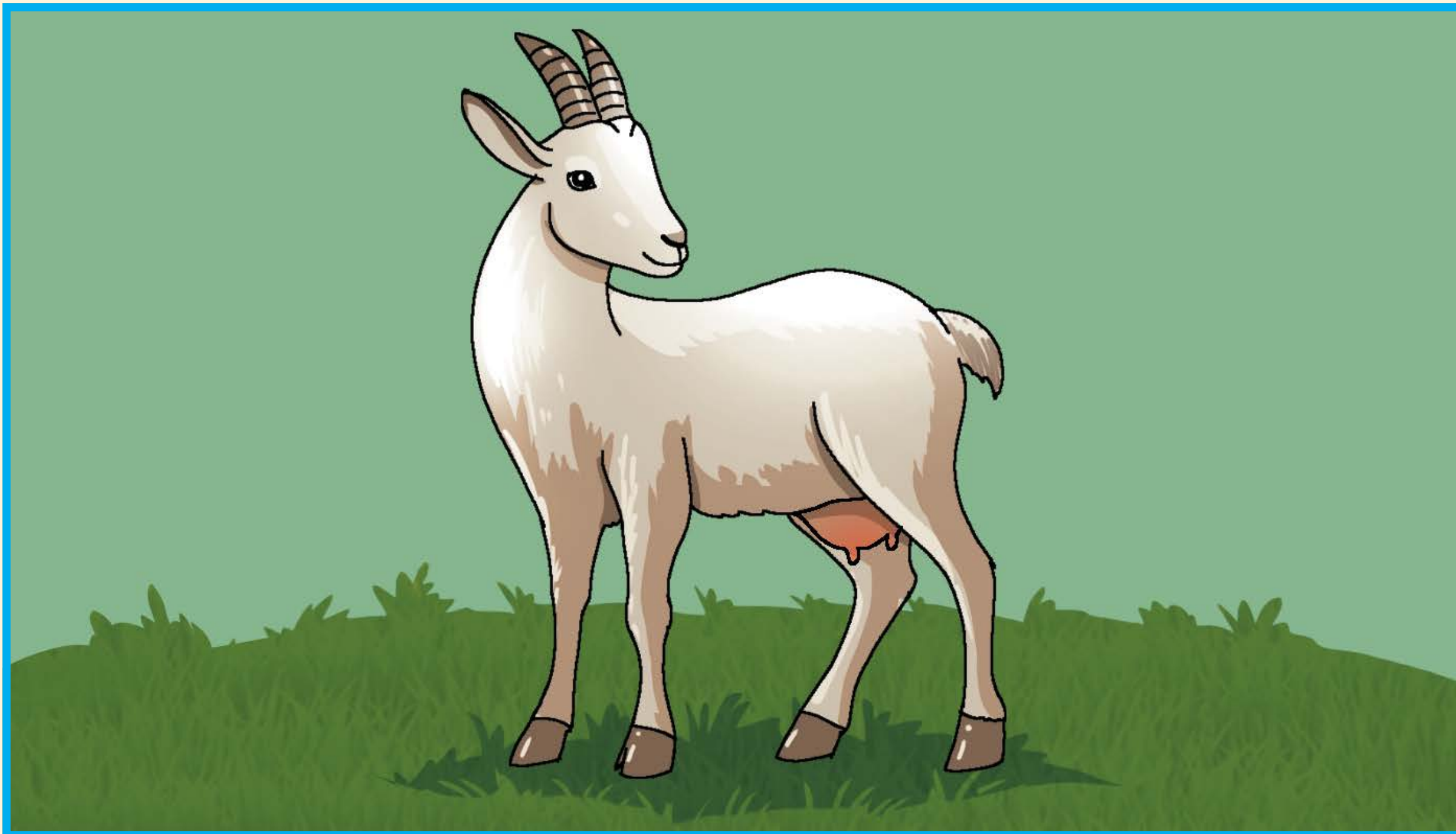

A goat gives milk and **m**eat.

goat

g

G

Name the pictures and match them with the letters.

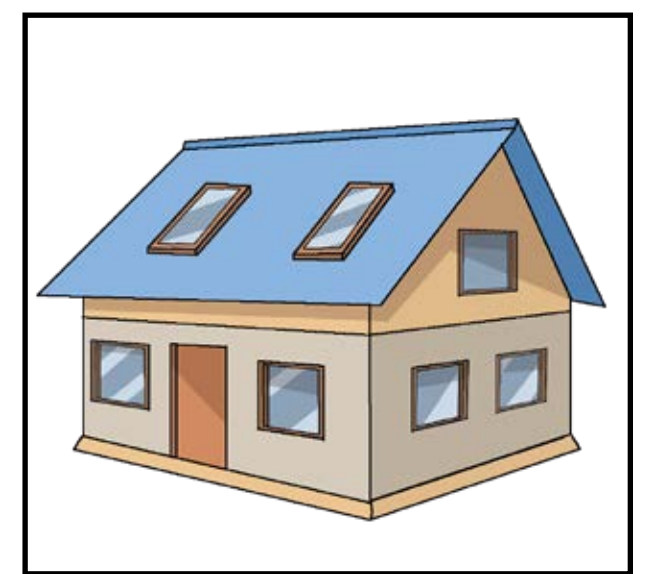
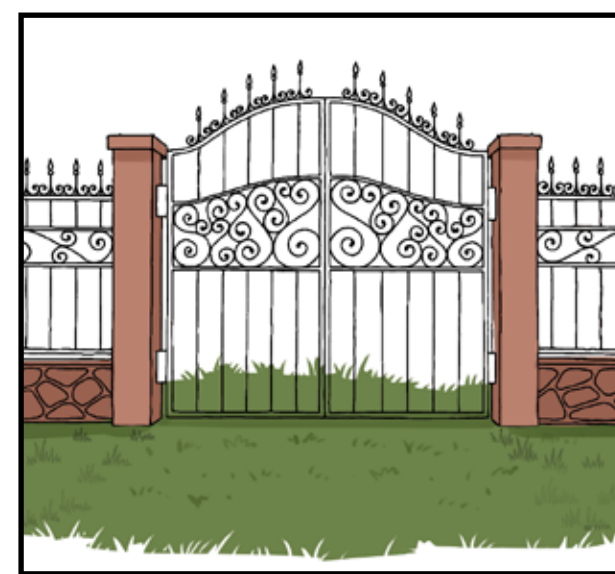
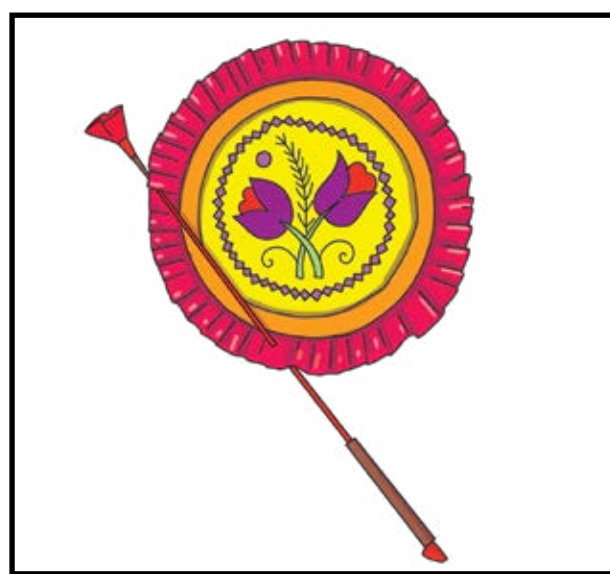
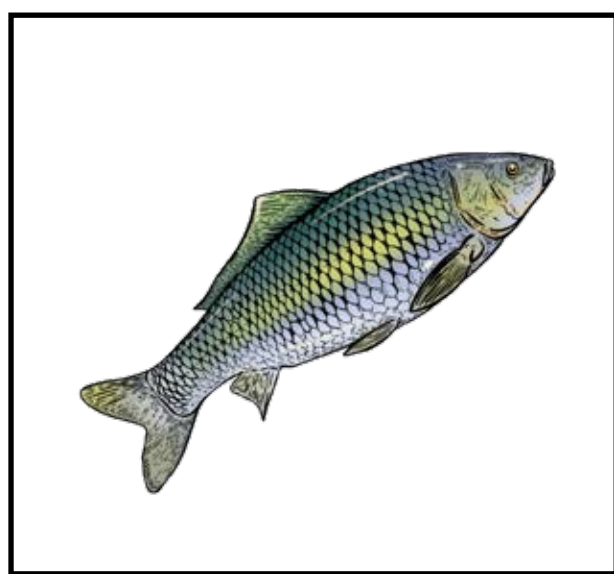

F

G

H

f

g

h



# Accelerated Adult Learning - Basic Literacy

## Lesson 8 Carpentry and Trades

Name the letter and its sound.

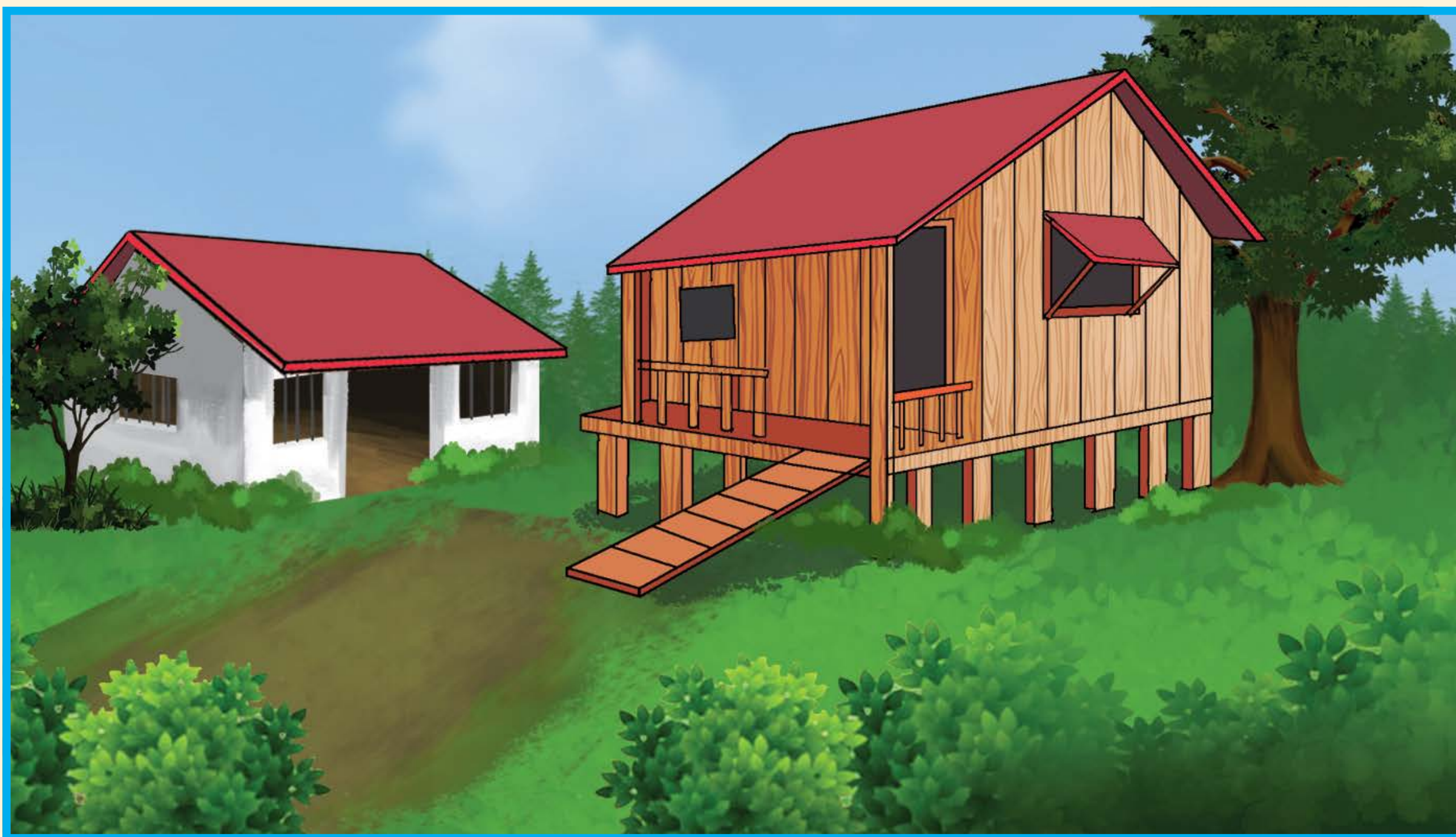

A carpenter made this **h**ouse.

house

h

H

Name the pictures and match them with the letters.

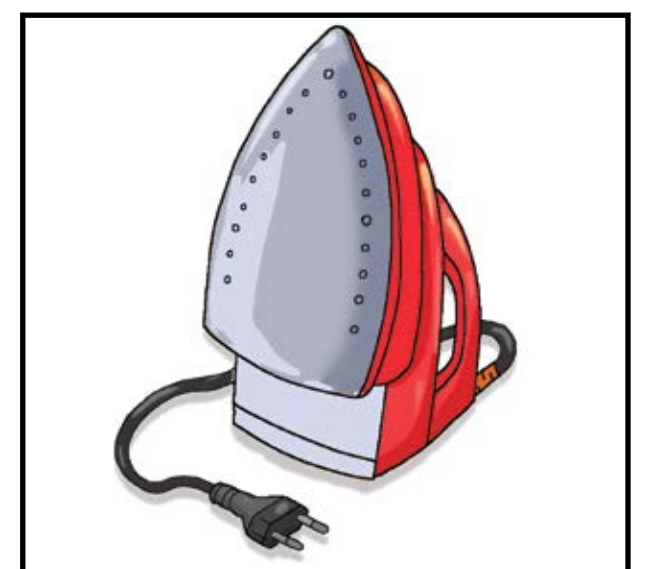
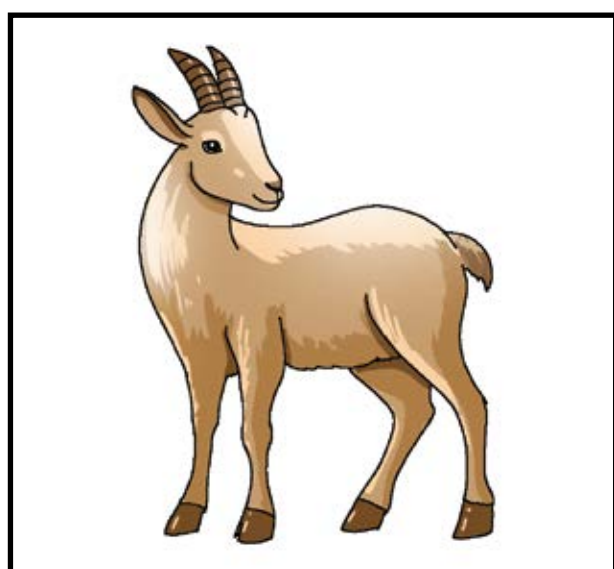
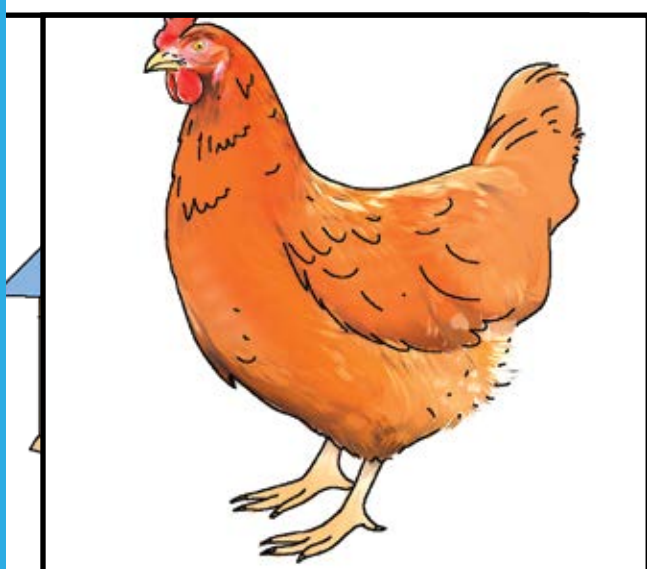

G

H

I

g

h

i



# Accelerated Adult Learning - Basic Literacy

## Lesson 9 Laundry

Name the letter and its sound.

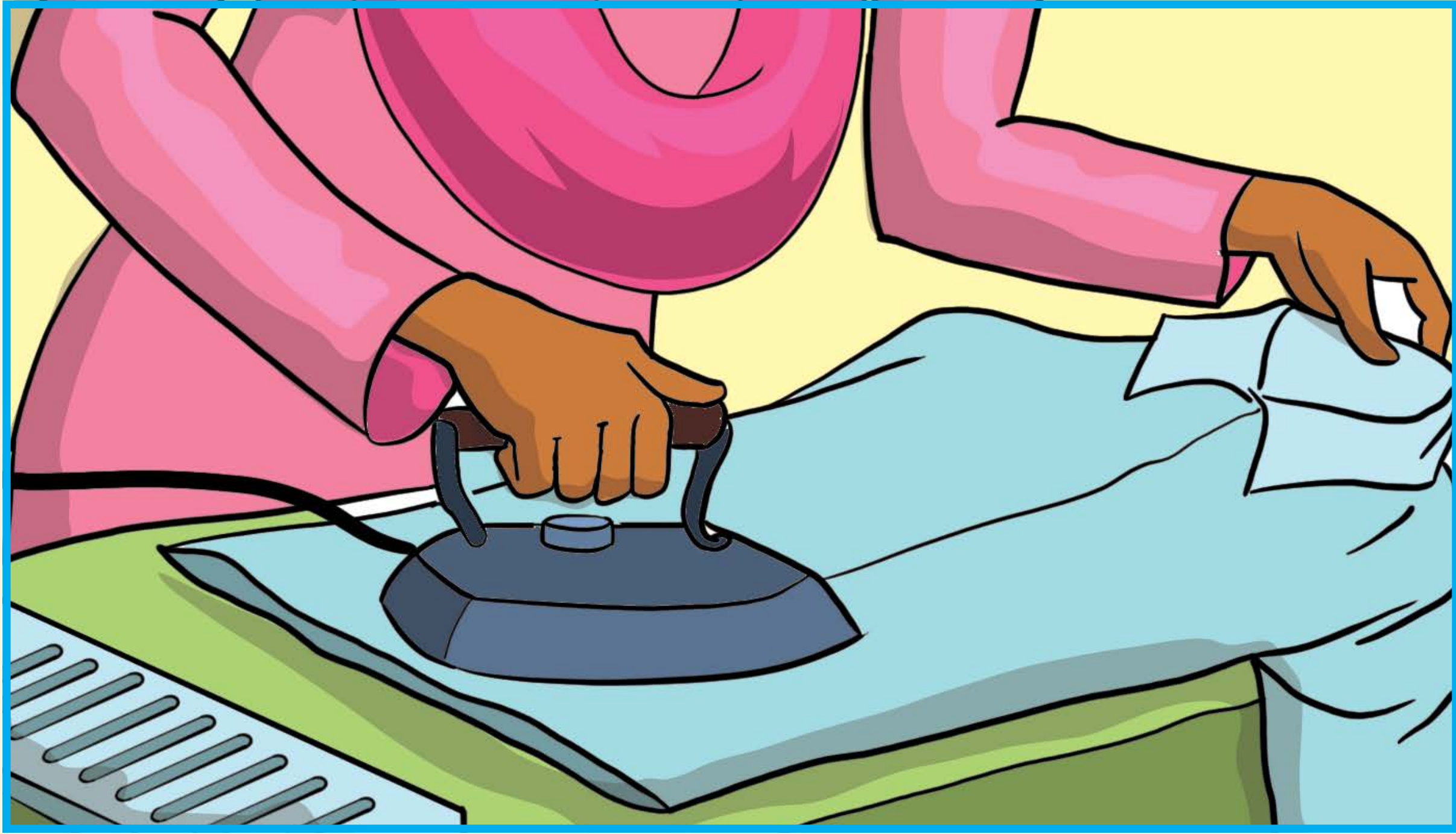

I use an iron to iron **c**lothes.

iron

i  
|

Name the pictures and match them with the letters.

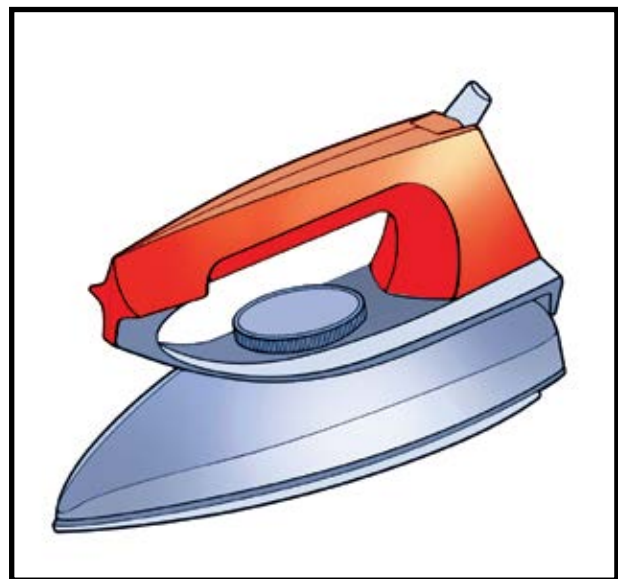

H

I

J

h

i

j



# Accelerated Adult Learning - Basic Literacy

## Lesson 10

### Review

Name the letter and its sound.



I use a **bag** for shopping.

	bag	
b	a	g
	bag	

Name the pictures and match them with the Letters.

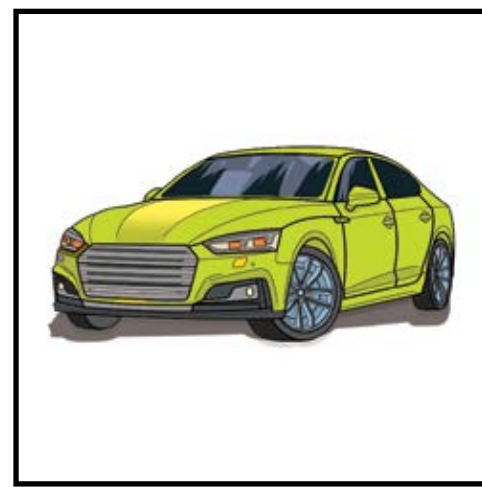
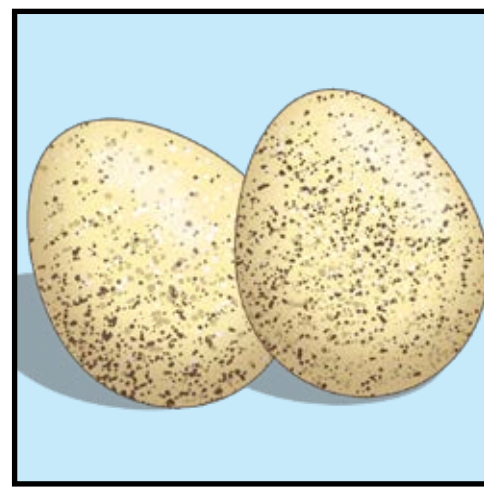

A   B   C   D   E   a   b   c   d   e

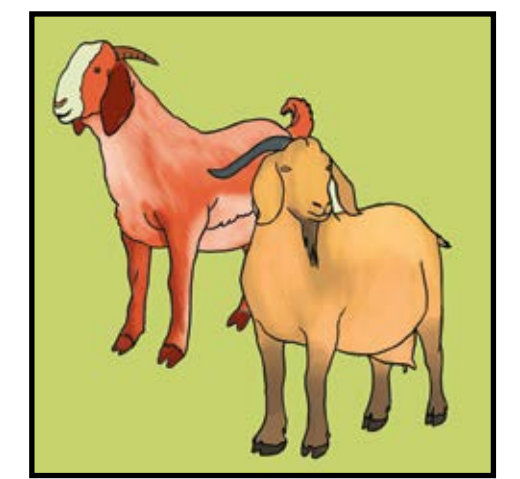
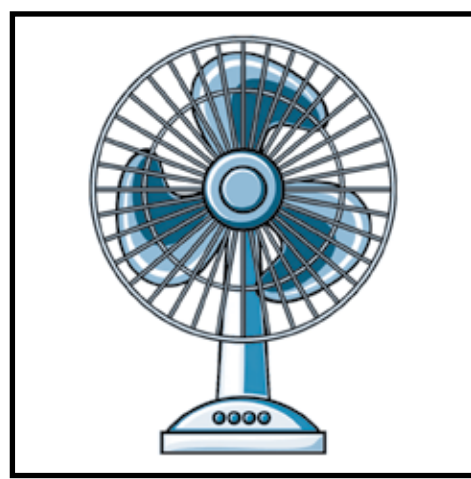

F   G   H   I   f   g   h   i



# Accelerated Adult Learning (Basic Literacy) **Lesson 11-20** Flipchart



**ISEC** 

Improving Skills and  
Economic Opportunities  
for Cox's Bazar



# Accelerated Adult Learning - Basic Literacy

## Lesson 11

### Fruit

Name the letter and its sound.



Asma made apple jam.

jam

j

J

Name the pictures and match them with the letters.

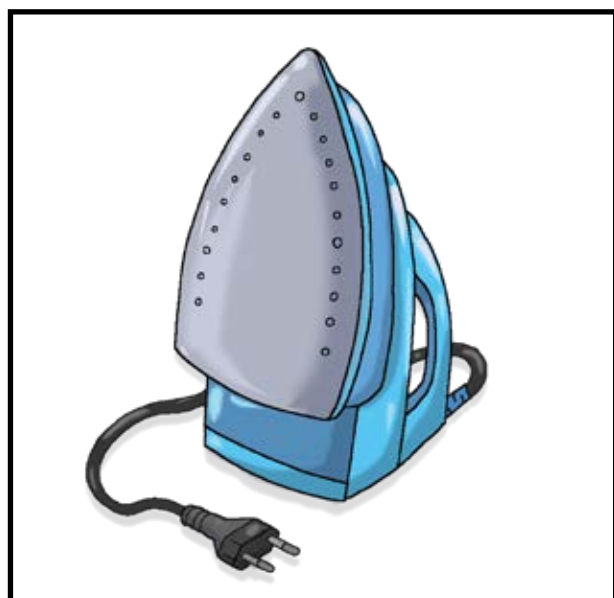

I

J

K

i

j

k



# Accelerated Adult Learning - Basic Literacy

## Lesson 12

### Tea Sellers

Name the letter and its sound.

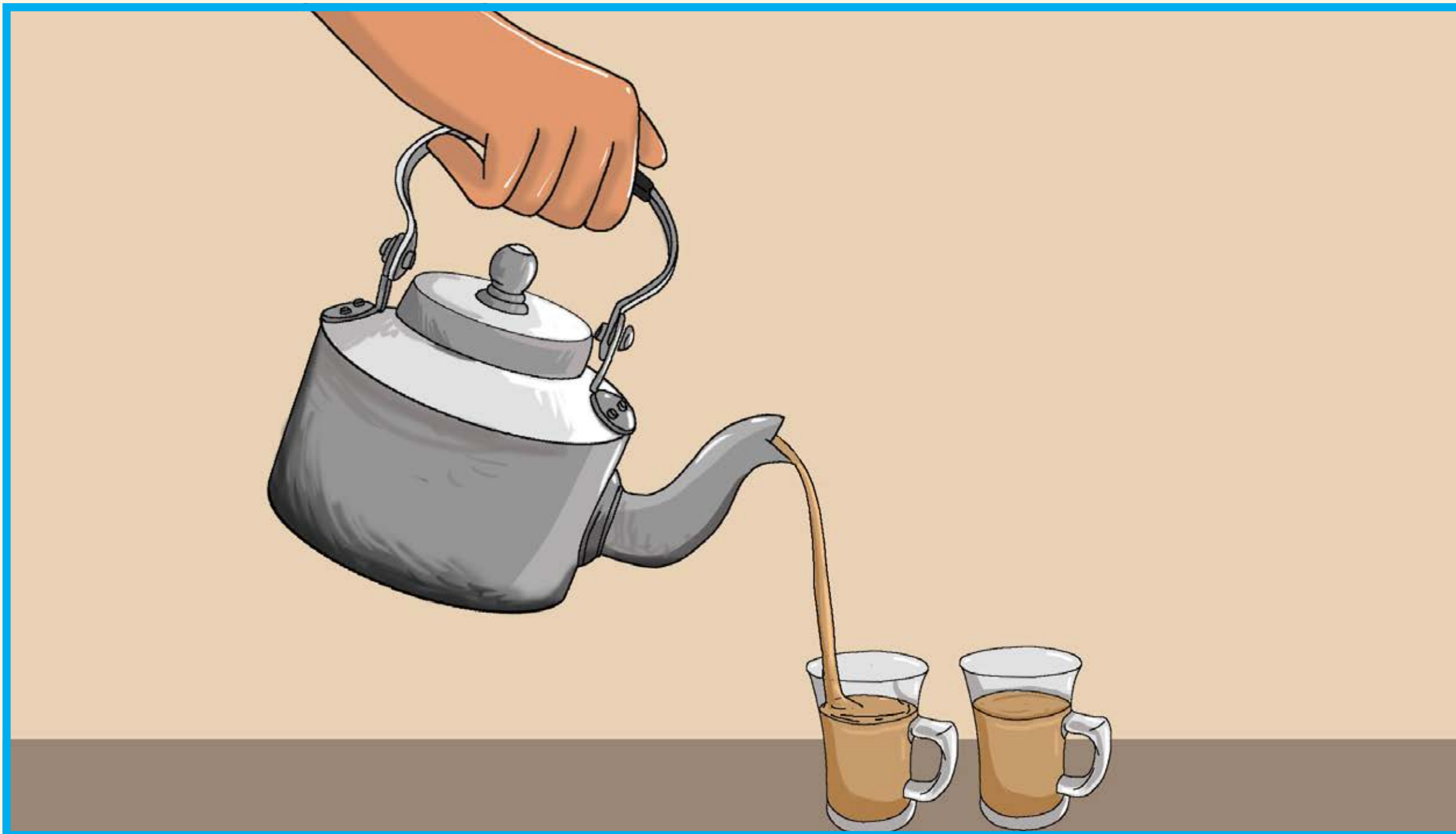

We need a **k**ettle to make tea.

kettle

k

K

Name the pictures and match them with the letters.

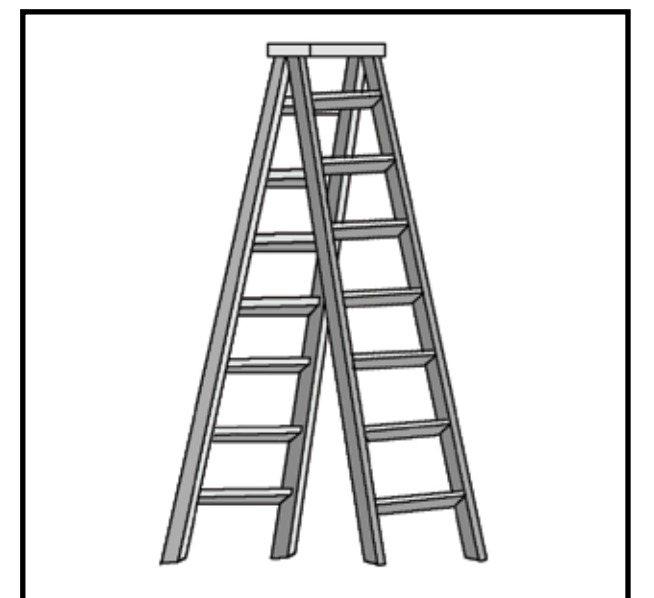

J

K

L

j

k

l



# Accelerated Adult Learning - Basic Literacy

## Lesson 13

### Masonry

Name the letter and its sound.



The mason used a ladder.

ladder

l

L

Name the pictures and match them with the letters.

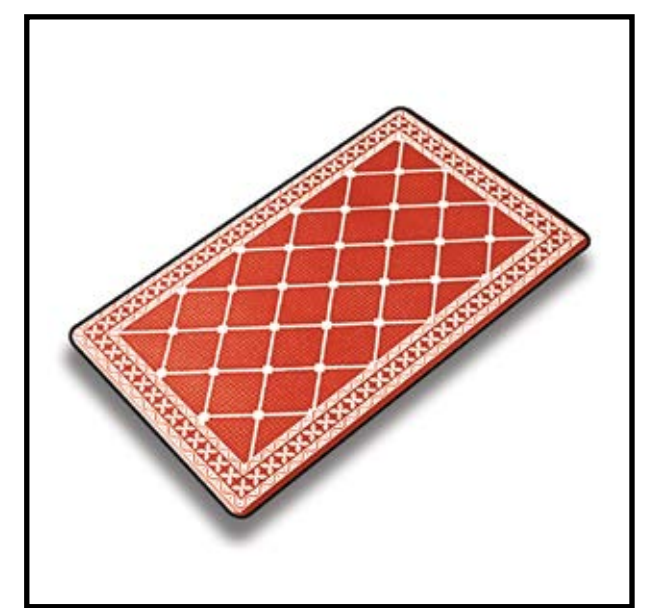
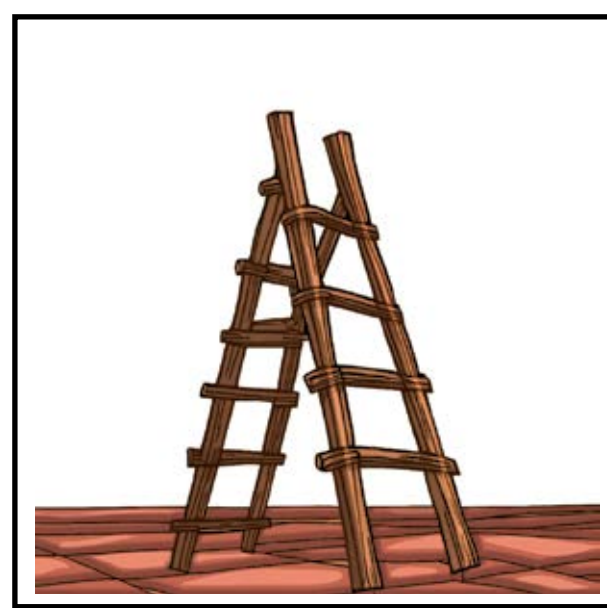
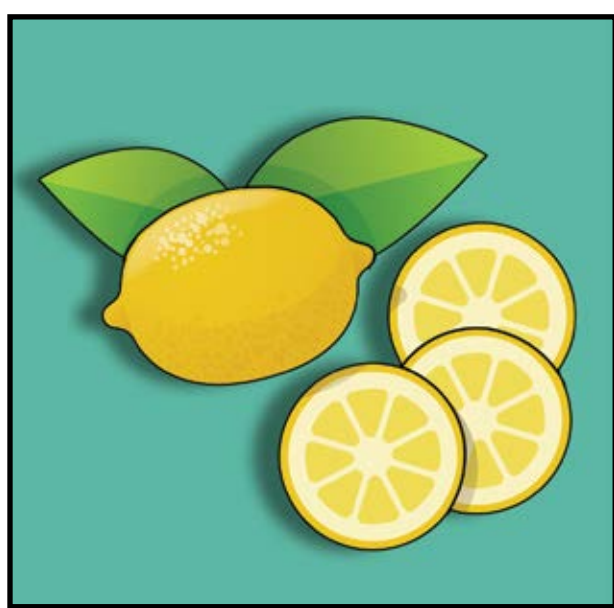

K

L

M

k

l

m



# Accelerated Adult Learning - Basic Literacy

## Lesson 14 Mat Making

Name the letter and its sound.

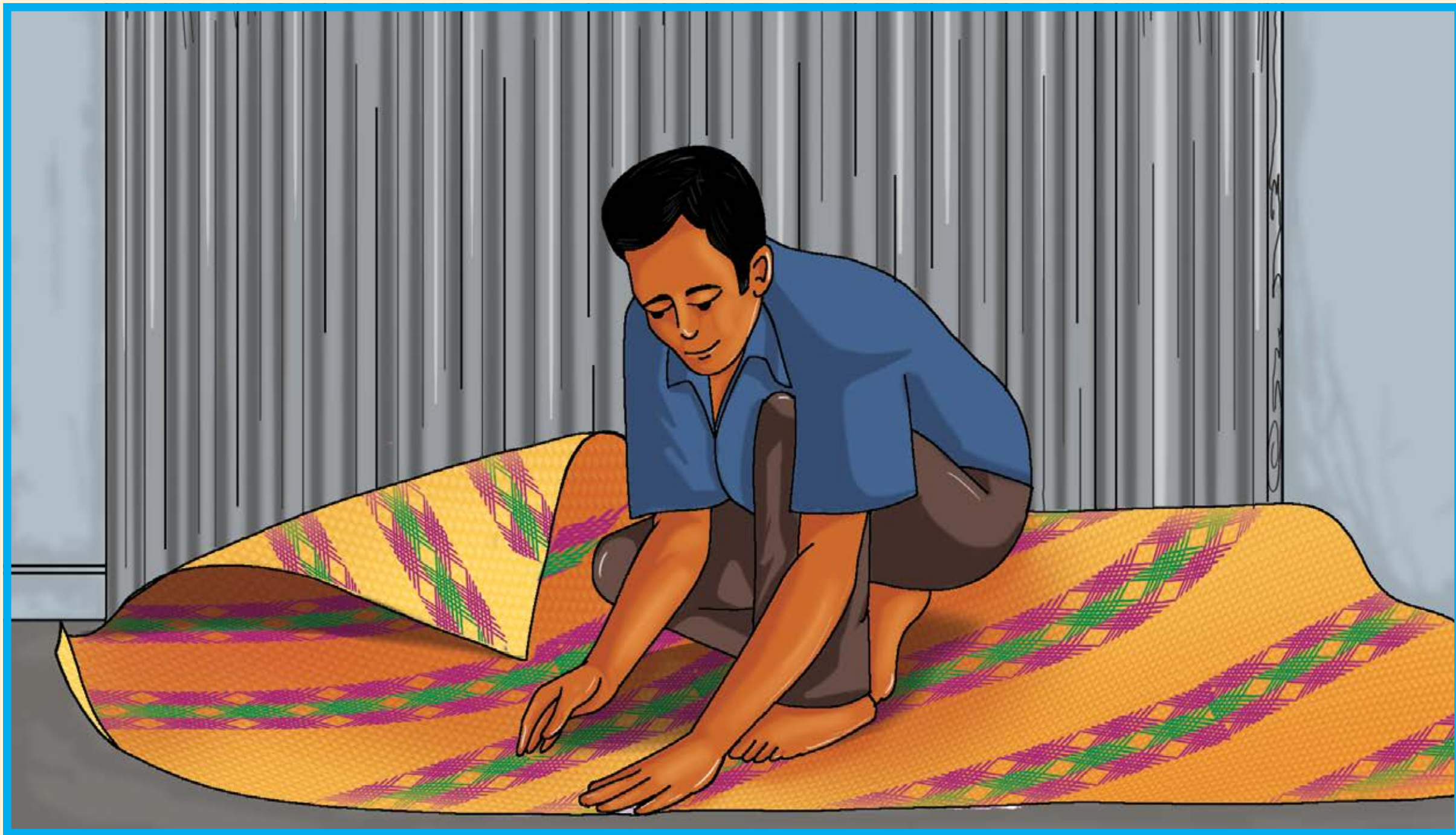

Father weaved a **m**at.

**m**at

m

M

Name the pictures and match them with the letters.

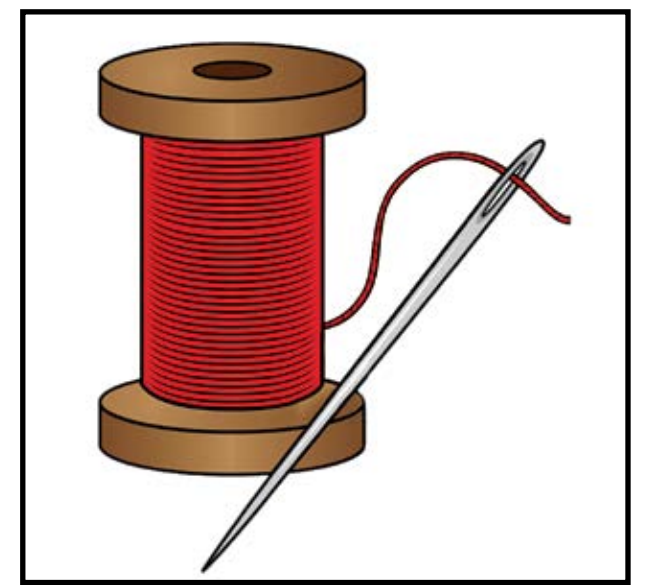
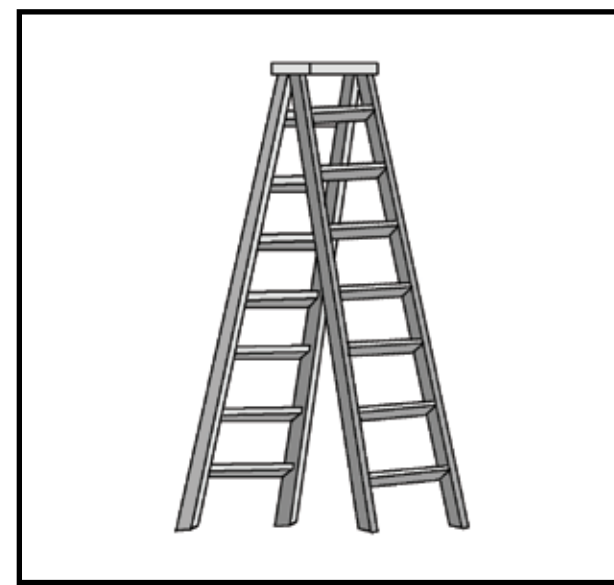
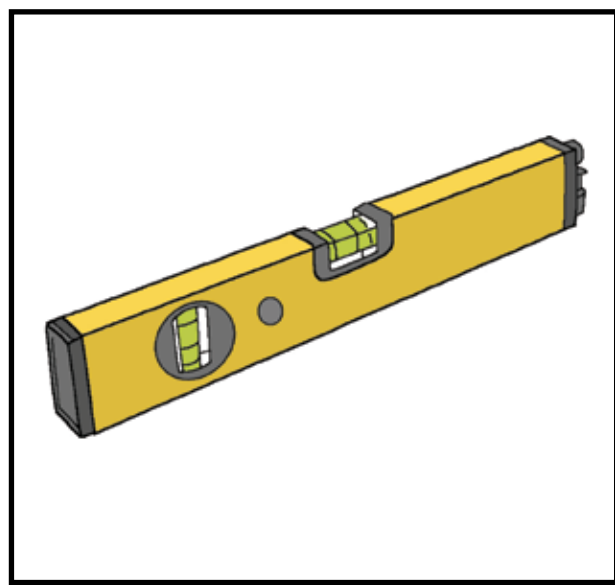
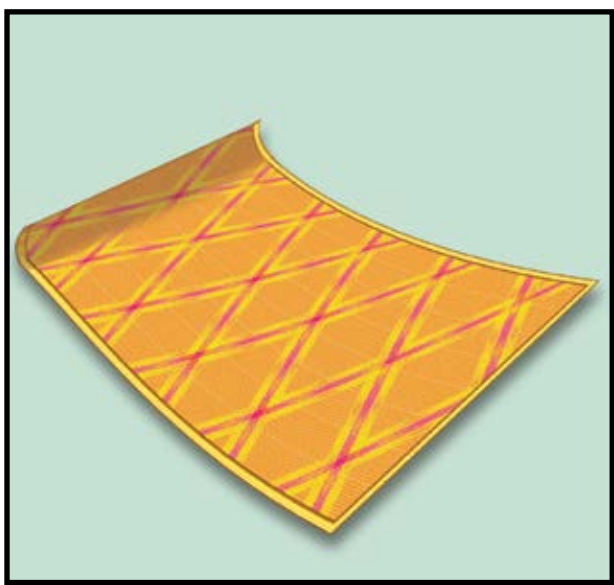

L

M

N

I

m

n



# Accelerated Adult Learning - Basic Literacy

## Lesson 15

### Sewing

Name the letter and its sound.



Mother has a **n**eedle for sewing.

needle

n

N

Name the pictures and match them with the letters.

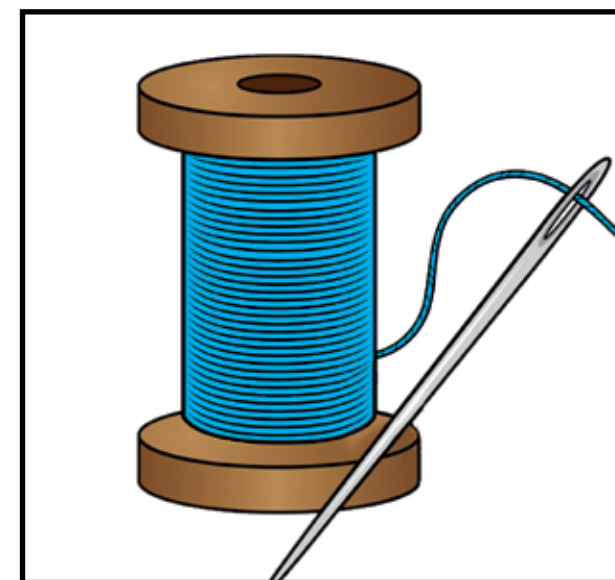
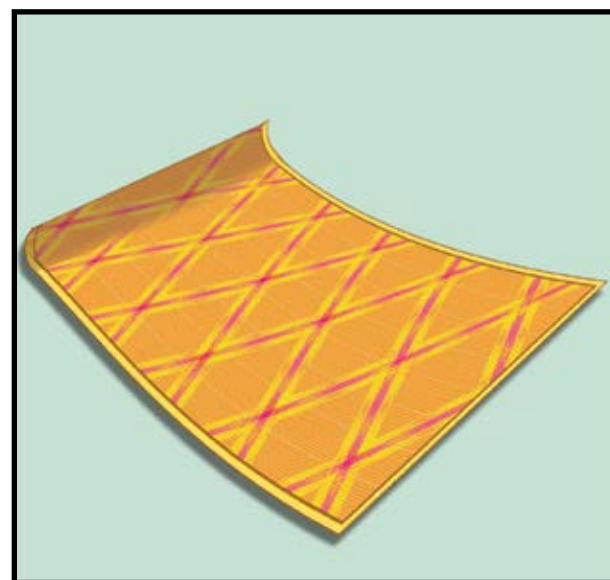
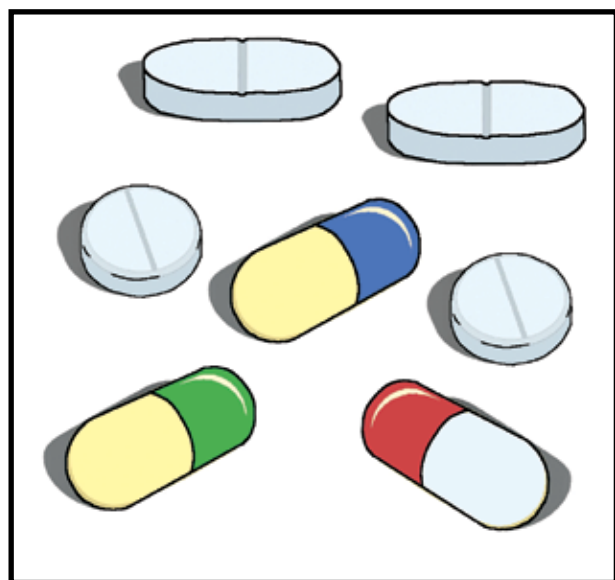
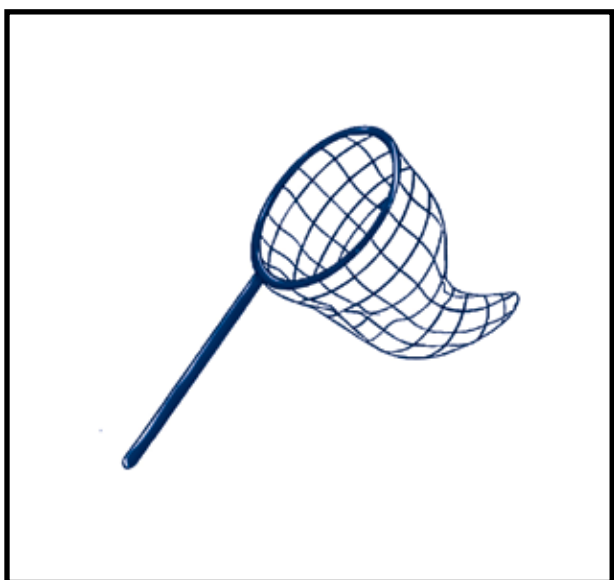

M

N

O

m

n

o



# Accelerated Adult Learning - Basic Literacy

## Lesson 16 Saving Trees

Name the letter and its sound.



We do not cook on a mud **o**ven.

**o**ven

o

O

Name the pictures and match them with the letters.

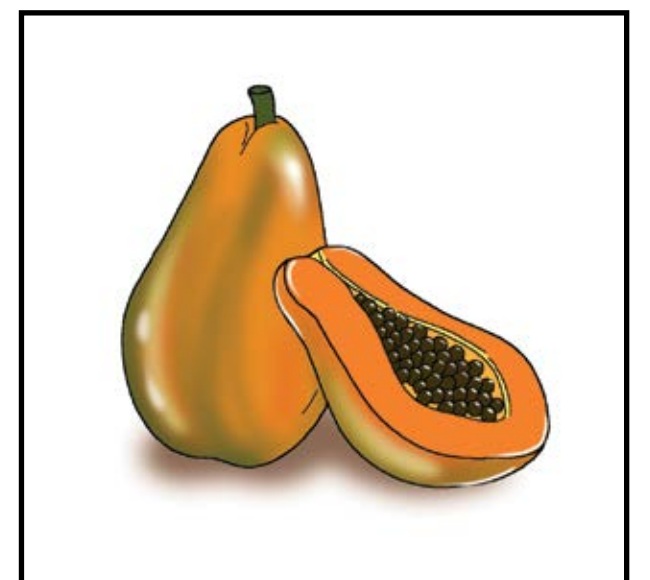
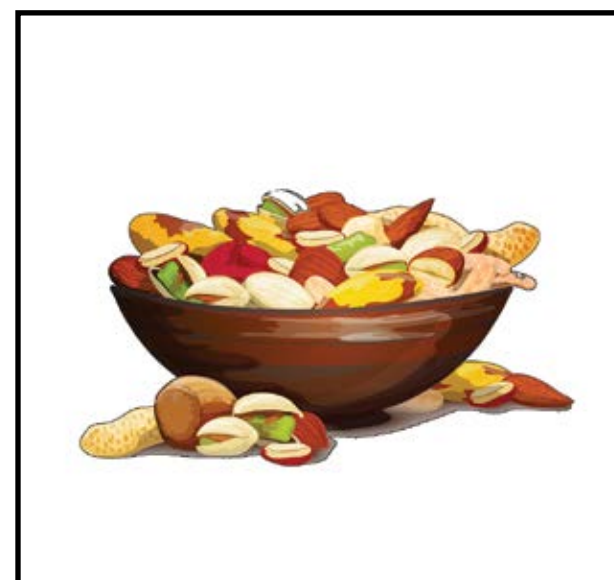
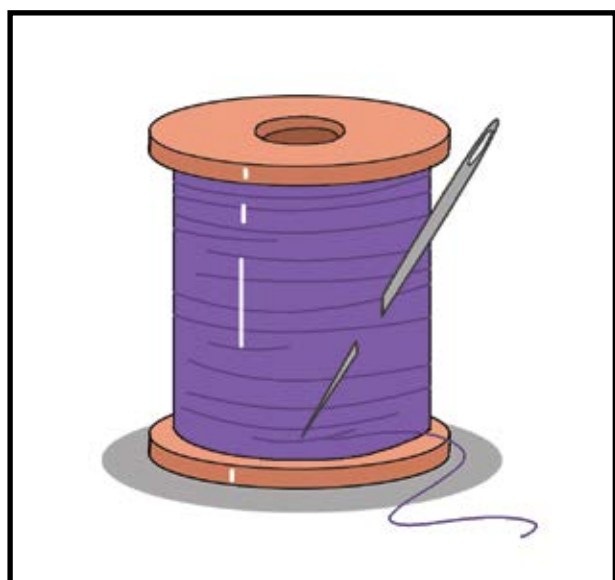

N

O

P

n

o

p



# Accelerated Adult Learning - Basic Literacy

## Lesson 17

### Fruit Trees

Name the letter and its sound.



Rahim planted a **p**apaya tree.

**p**apaya  
p  
P

Name the pictures and match them with the letters.

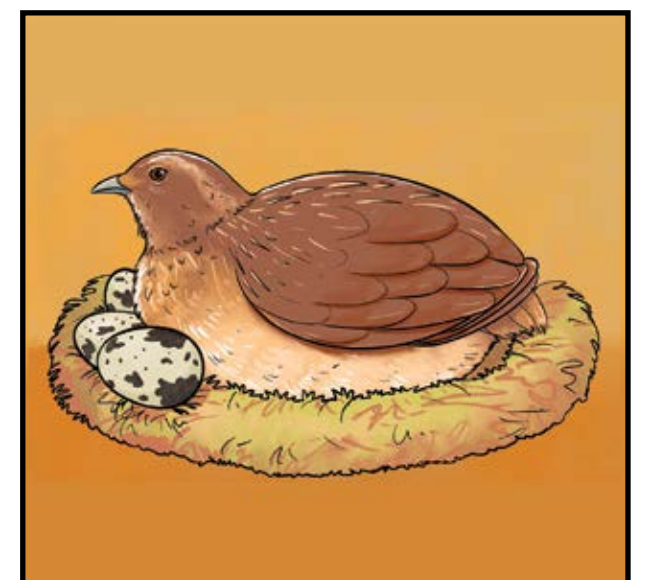
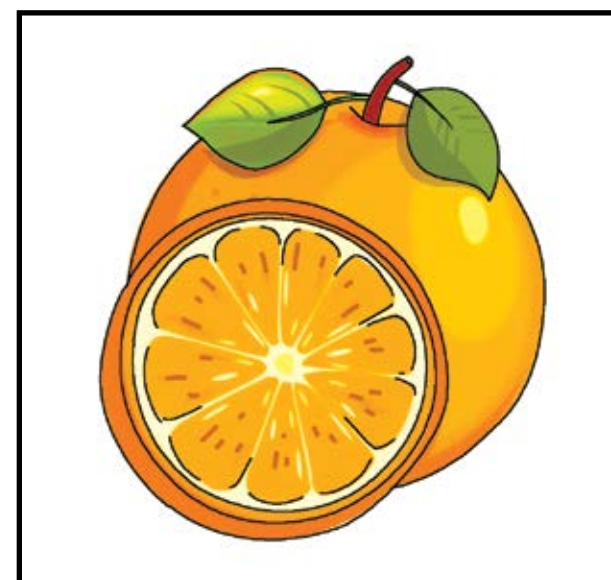
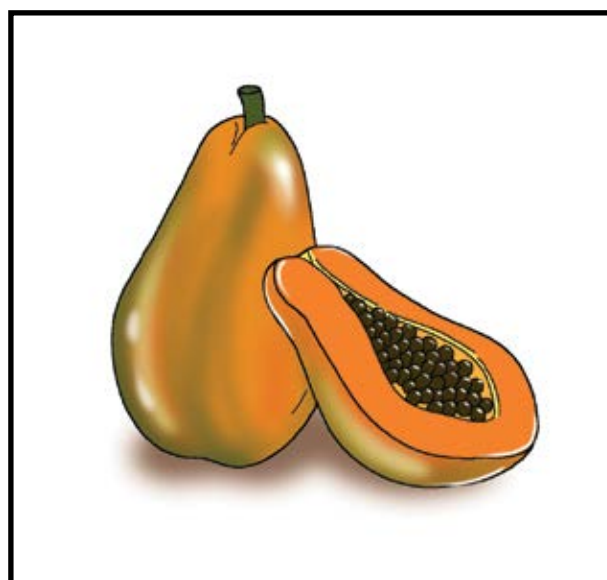
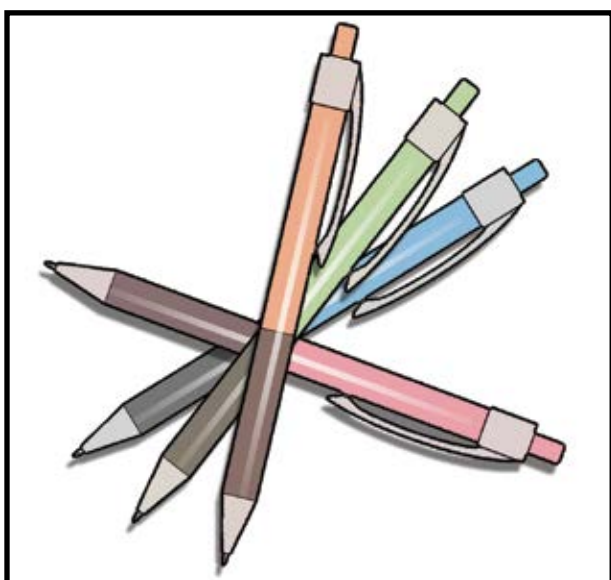

O

P

Q

o

p

q



# Accelerated Adult Learning - Basic Literacy

## Lesson 18

### Poultry Rearing

Name the letter and its sound.



It is easy to raise **q**uails.

quails

q

Q

Name the pictures and match them with the letters.

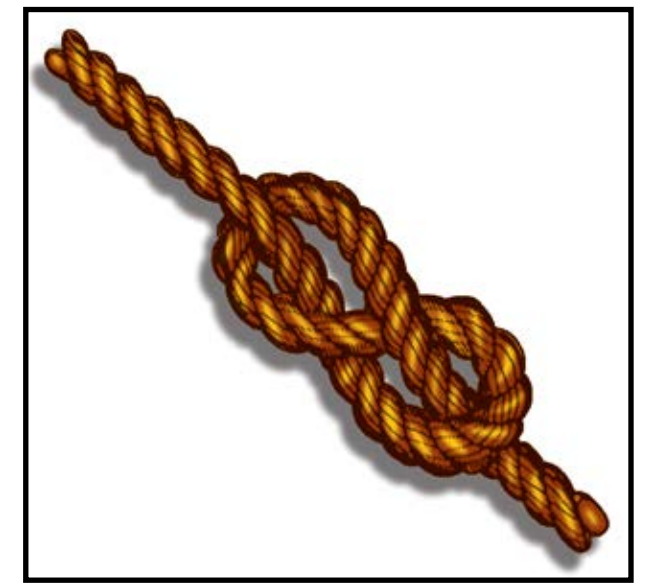
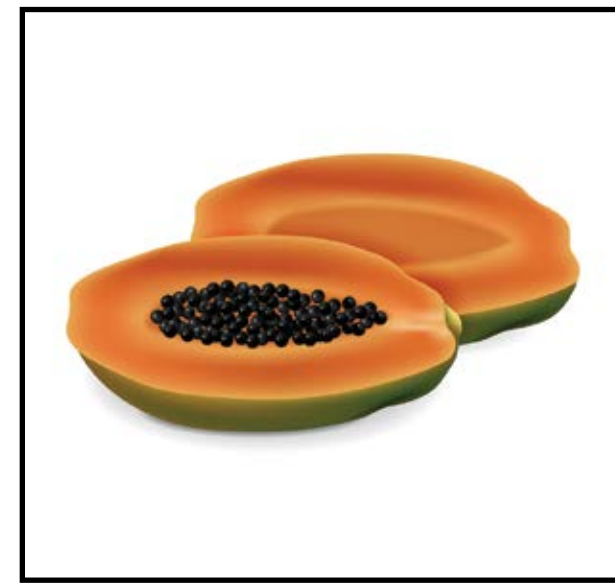
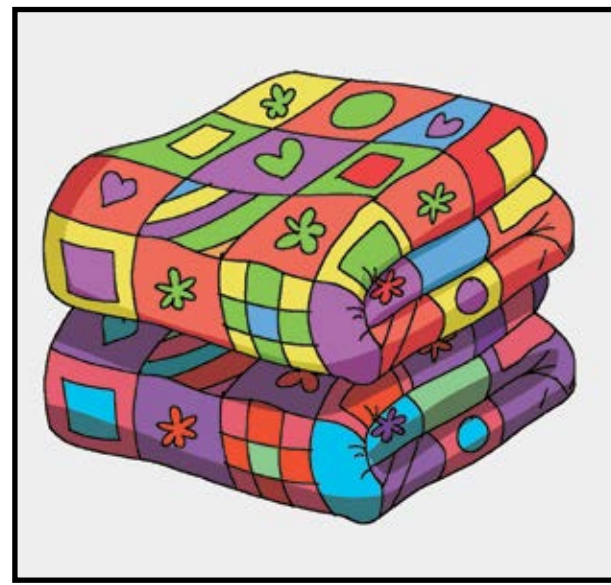
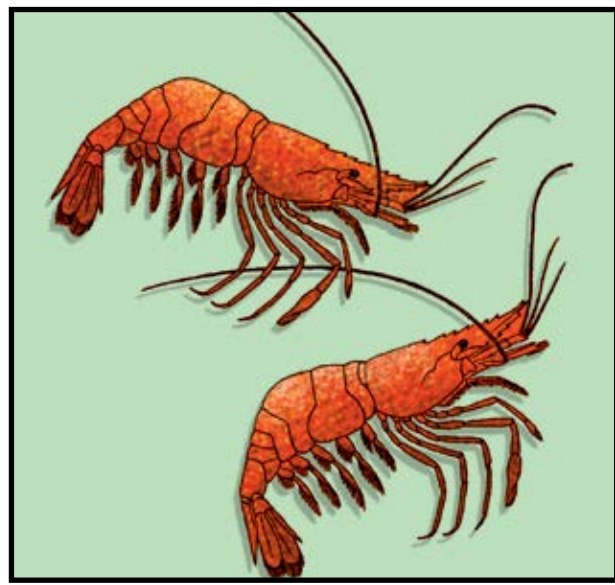
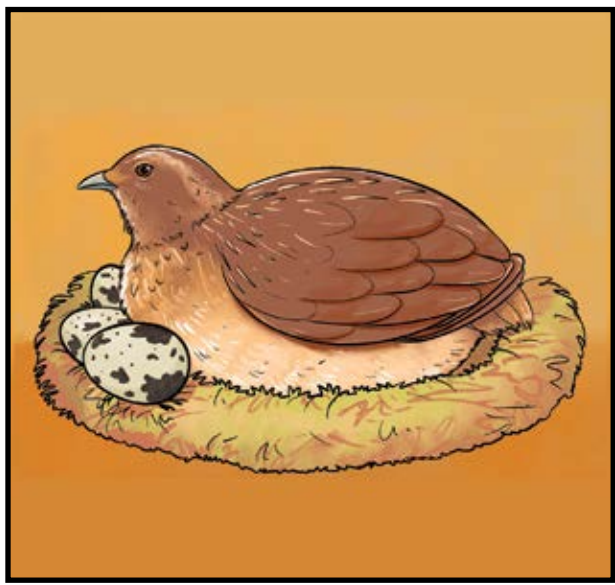

P

Q

R

p

q

r



# Accelerated Adult Learning - Basic Literacy

## Lesson 19 Cradles

Name the letter and its sound.

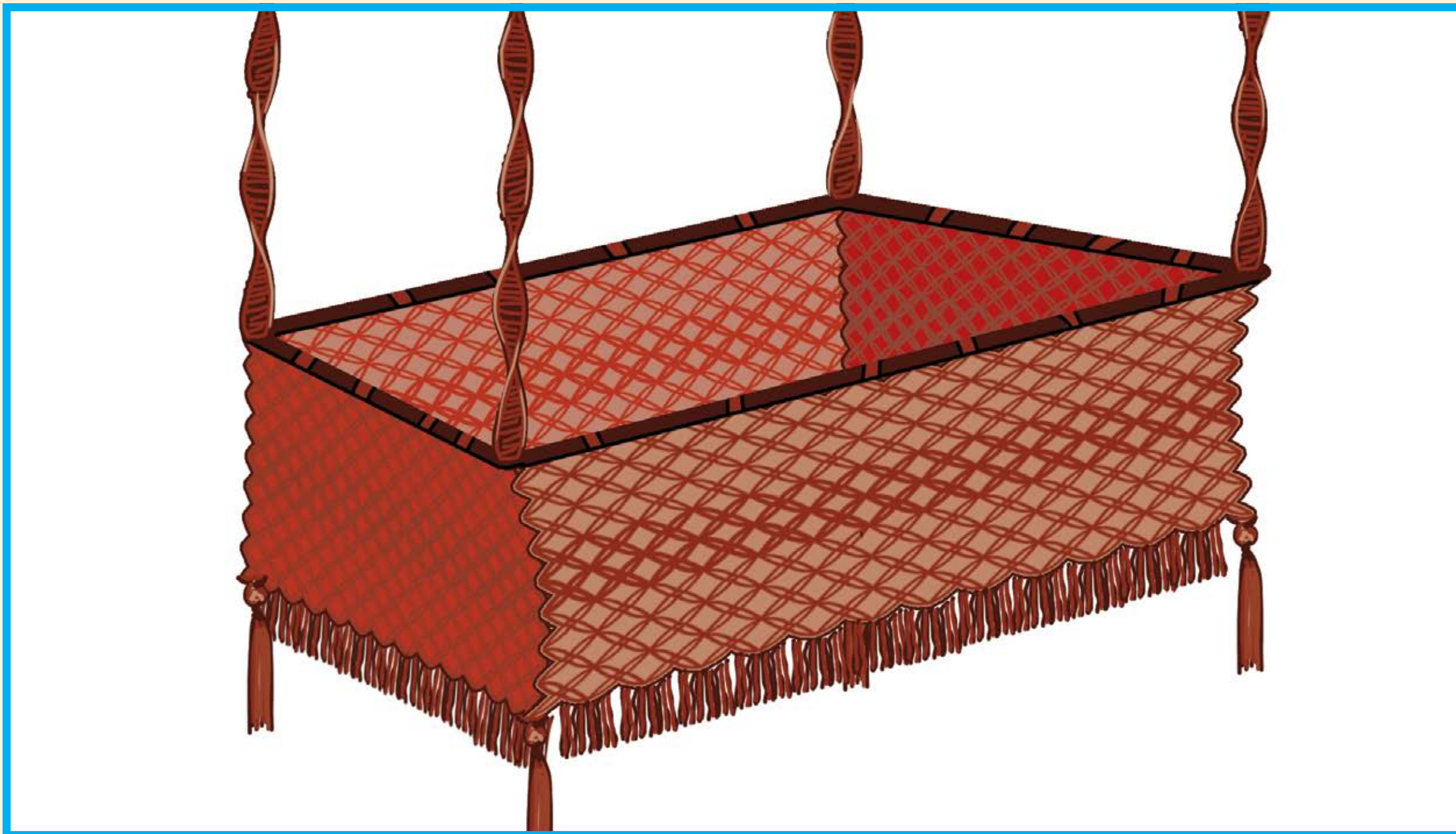

Asma made a cradle with rope.

rope

r

R

Name the pictures and match them with the letters.

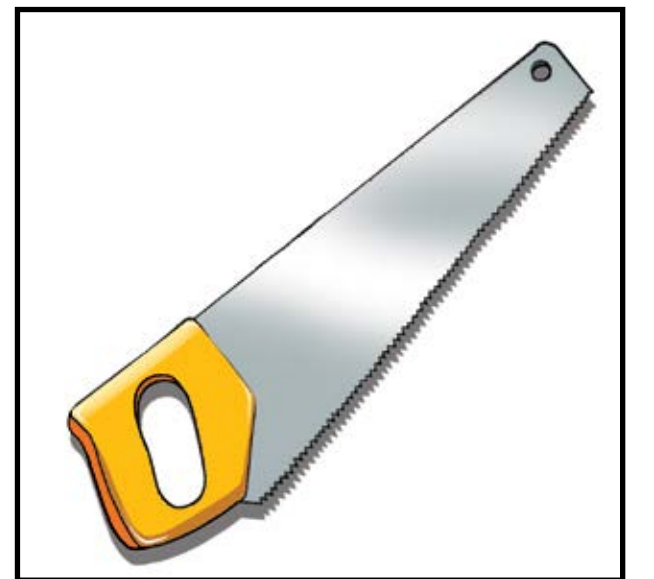
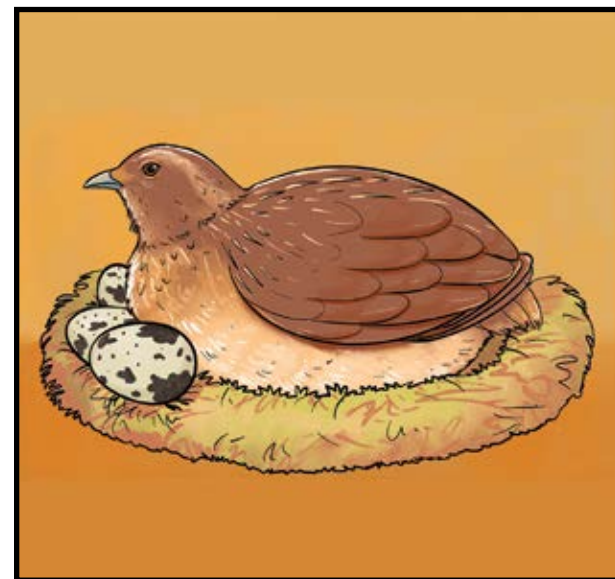
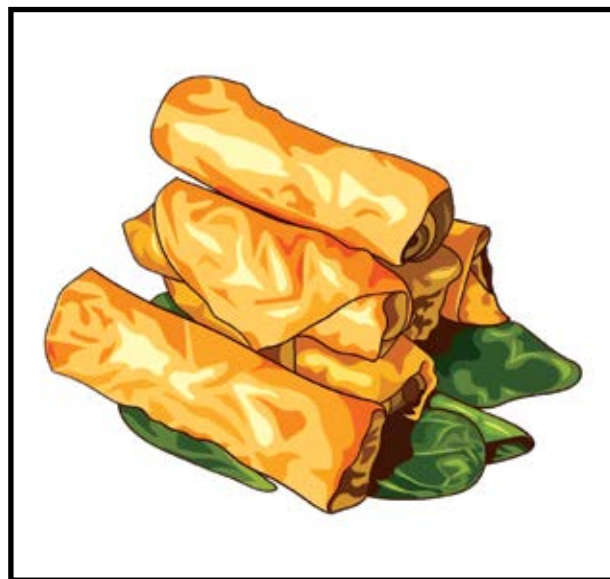
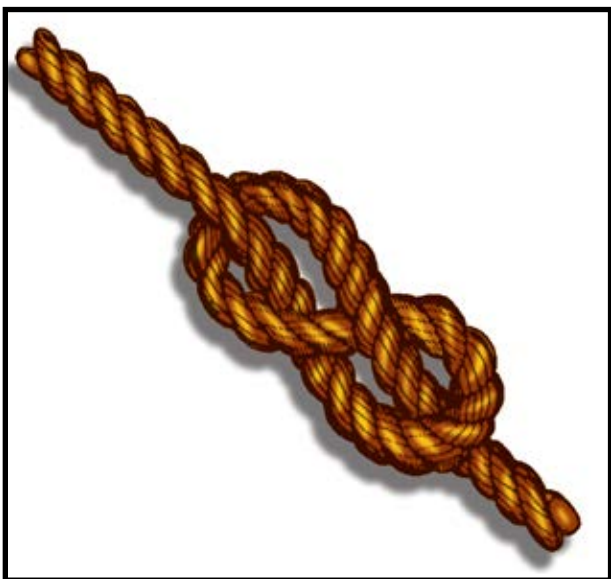

Q

R

S

q

r

s



# Accelerated Adult Learning - Basic Literacy

## Lesson 20

### Review

Name the letter and its sound.



We cook with an iron **pan**.

	pan	
p	a	n
	pan	

Name the pictures and match them with the letter.

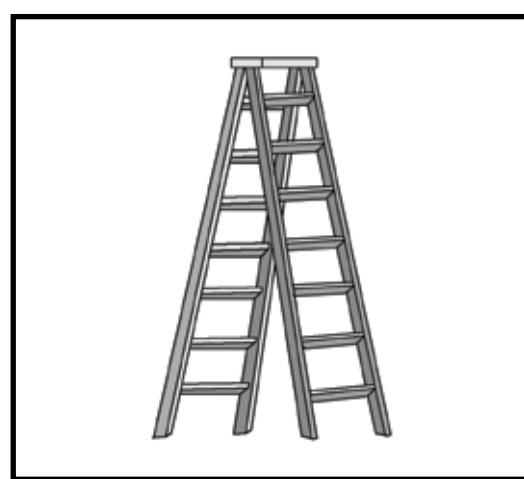
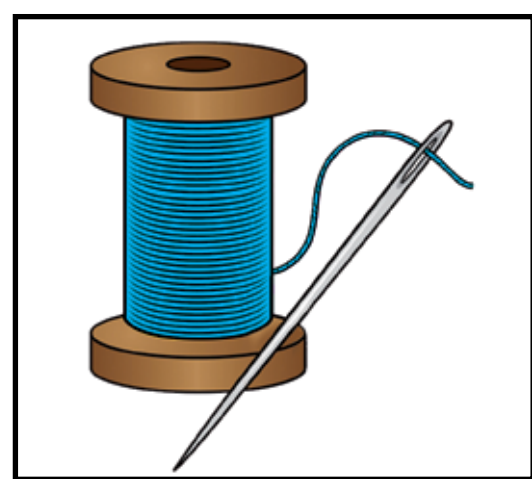
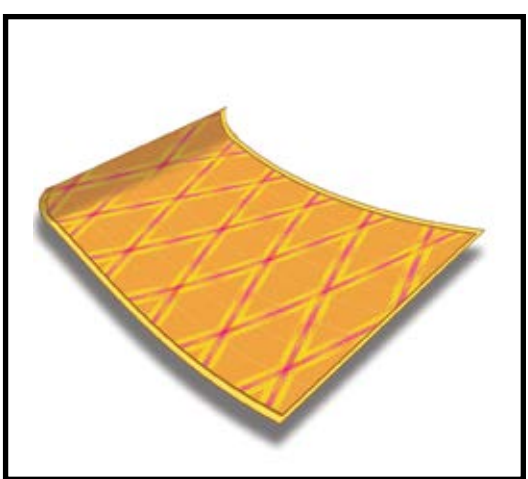

J K L M N j k l m n

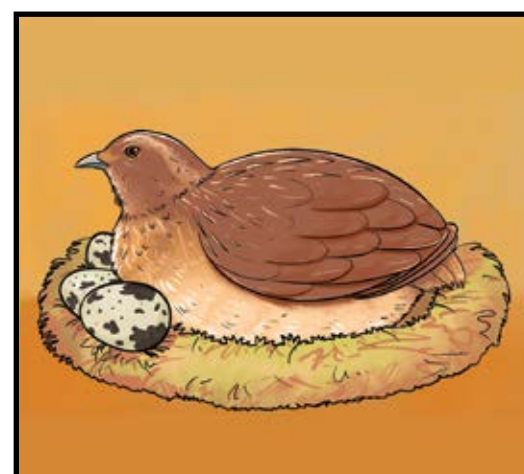

O P Q R o p q r



# Accelerated Adult Learning (Basic Literacy) **Lesson 21-30** Flipchart



**ISEC** 

Improving Skills and  
Economic Opportunities  
for Cox's Bazar



# Accelerated Adult Learning - Basic Literacy

## Lesson 21 A Carpenter's Tools

Name the letter and its sound.



I cut wood with a saw.

saw

s

S

Name the pictures and match them with the letters.

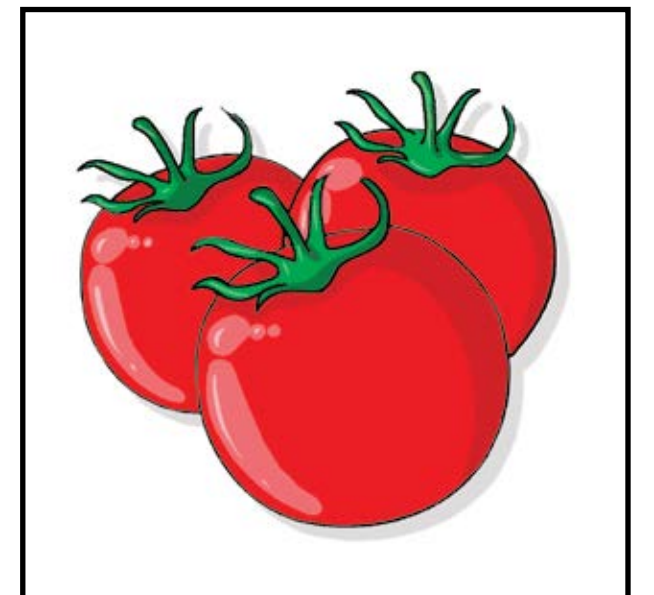
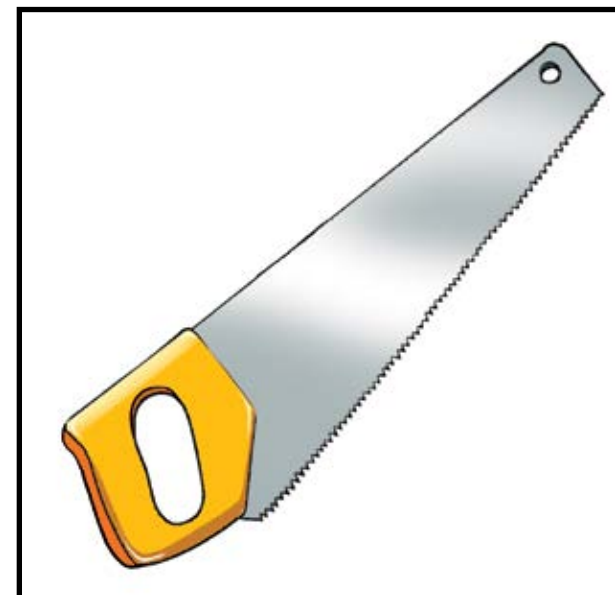
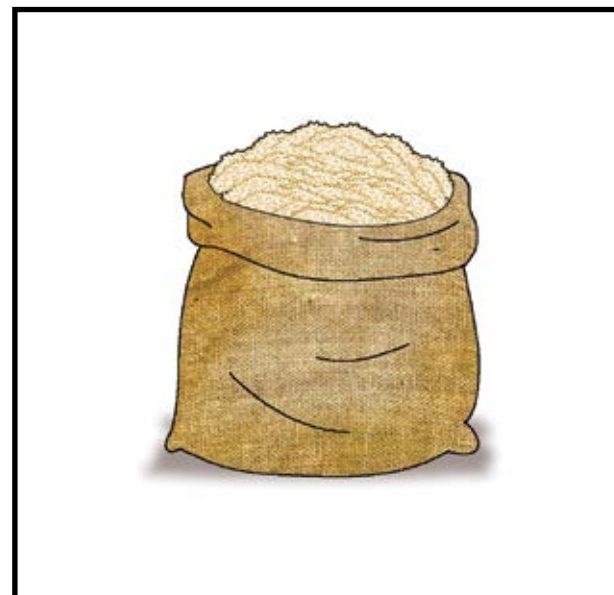
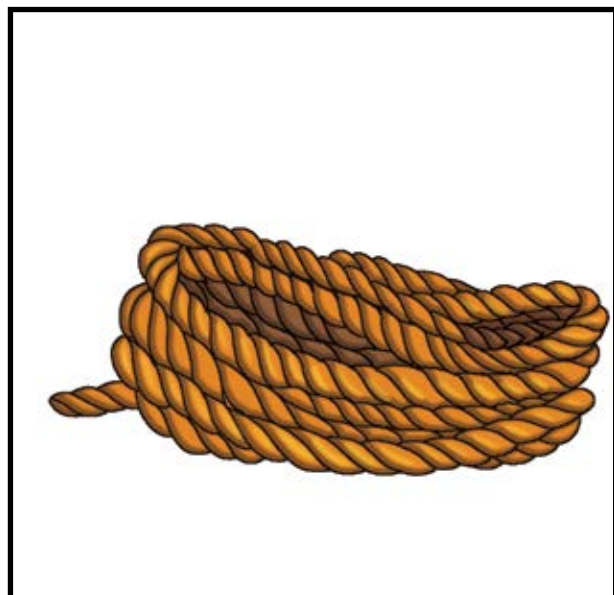

R

S

T

r

s

t



# Accelerated Adult Learning - Basic Literacy

## Lesson 22

### Growing Vegetables

Name the letter and its sound.

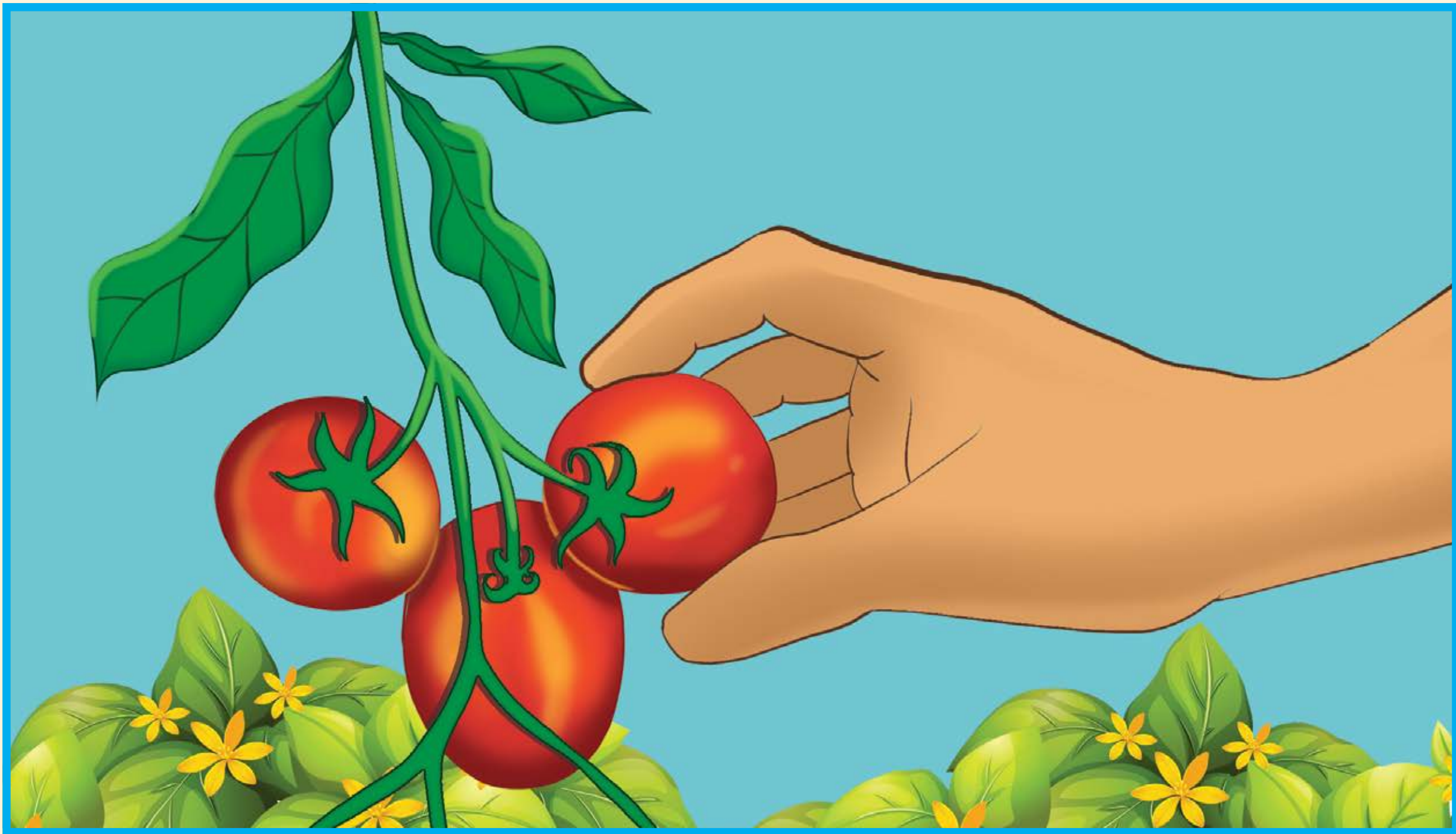

It is easy to grow **t**omatoes.

**t**omato

t

T

Name the pictures and match them with the letters.

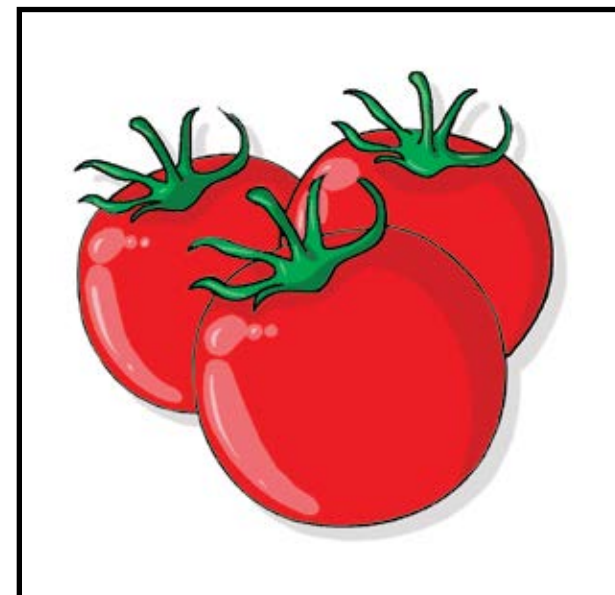

S

T

U

S

t

U



# Accelerated Adult Learning - Basic Literacy

## Lesson 23

### Umbrella Decorations

Name the letter and its sound.



I have a red **U**mbrella.

**U**mbrella

U

U

Name the pictures and match them with the letters.

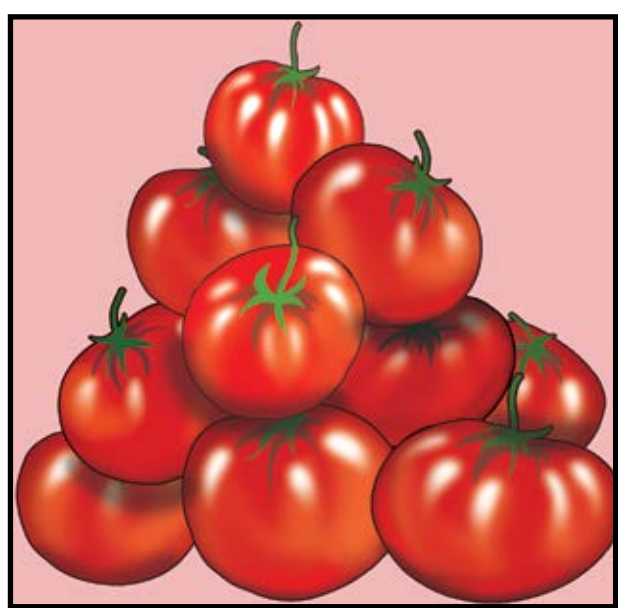

T

U

V

t

U

V



# Accelerated Adult Learning - Basic Literacy

## Lesson 24

### Drivers

Name the letter and its sound.

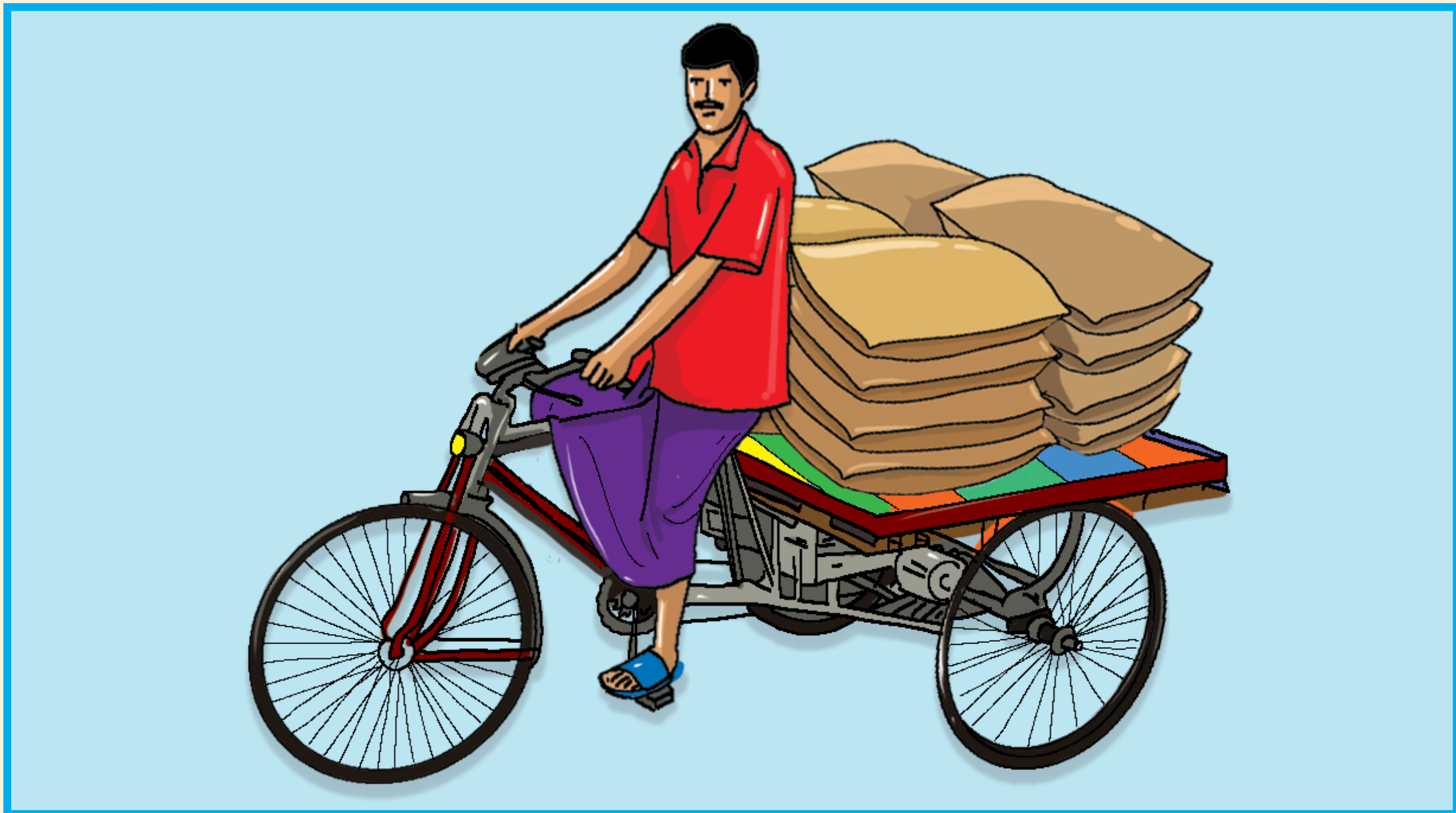

My brother drives a **v**an.

van  
v  
v

Name the pictures and match them with the letters.

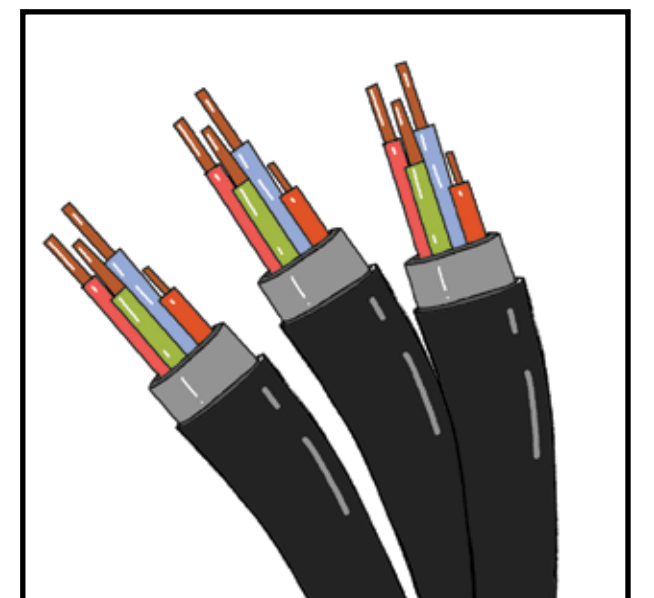
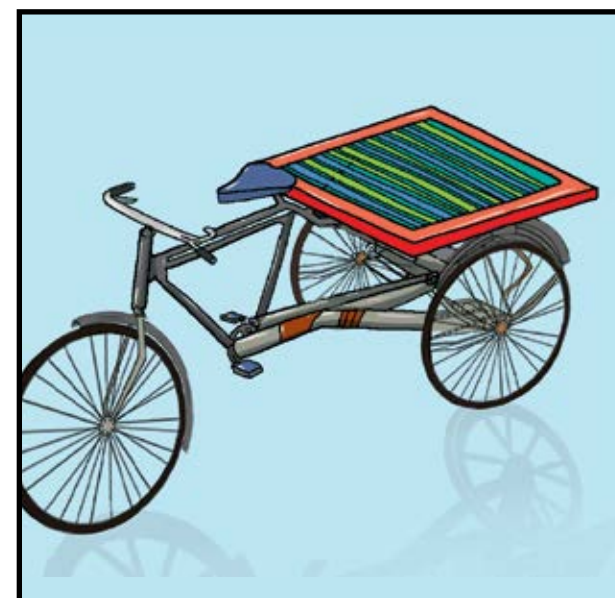

U      V      W      U      V      W



# Accelerated Adult Learning - Basic Literacy

## Lesson 25

### Electricians

Name the letter and its sound.

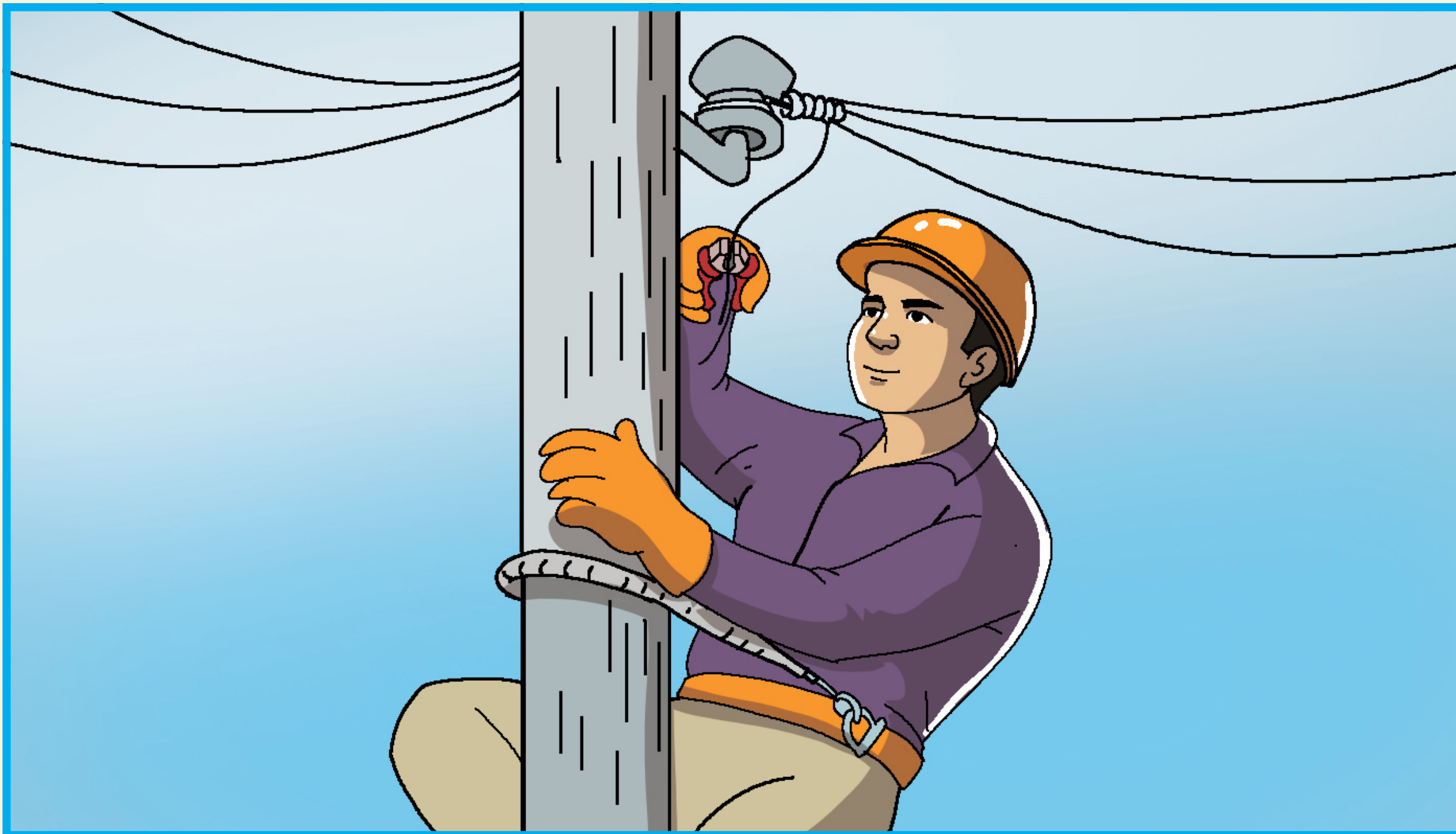

An electrician works with **w**ire.

Wire

w

W

Name the pictures and match them with the letters.

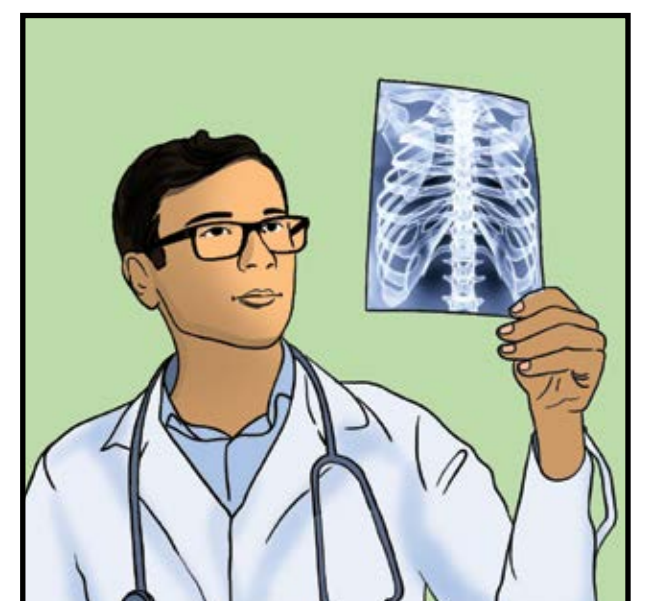
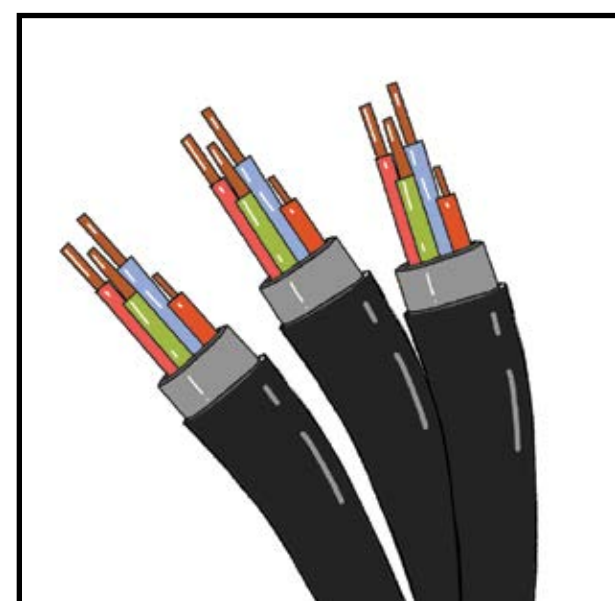
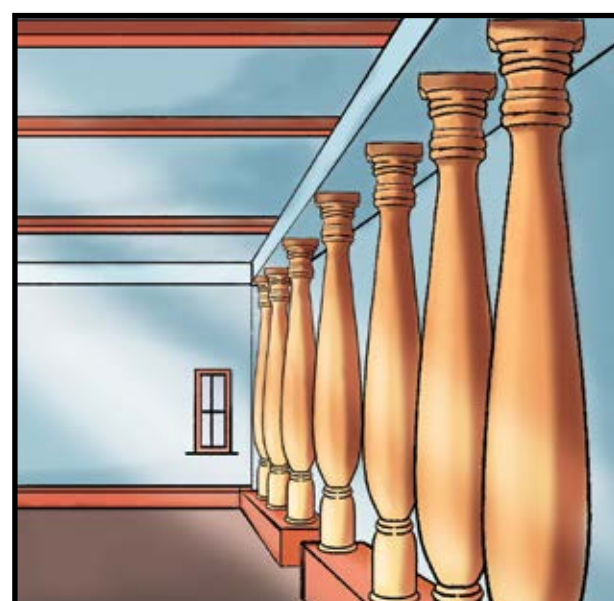
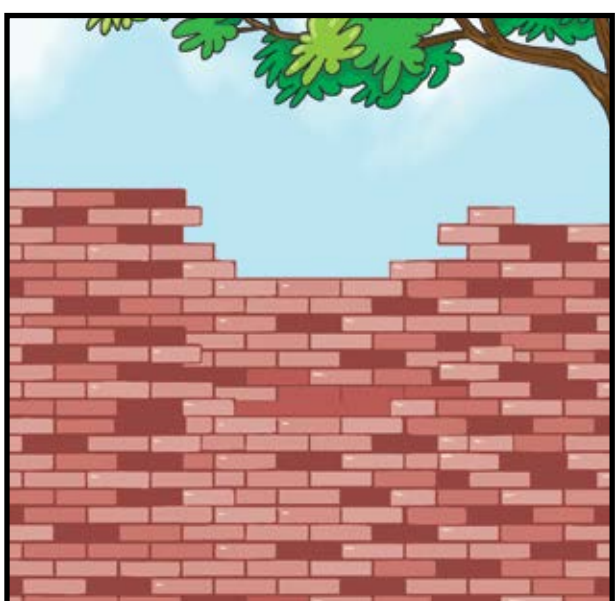

V

W

X

V

W

X



# Accelerated Adult Learning - Basic Literacy

## Lesson 26

### Health Workers

Name the letter and its sound.

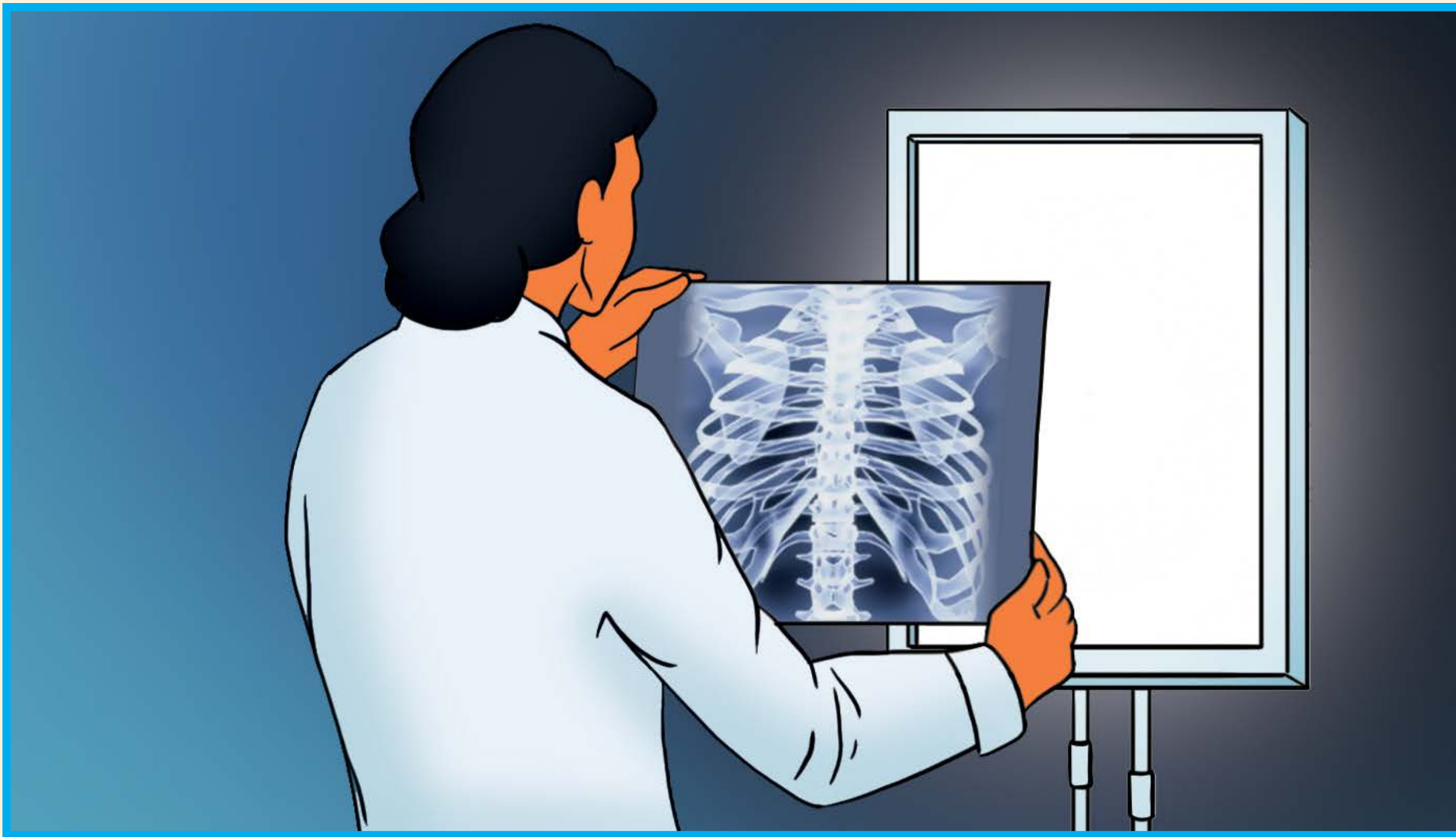

The doctor looked at the **x**-ray.

**x**-ray

x

X

Name the pictures and match them with the letters.

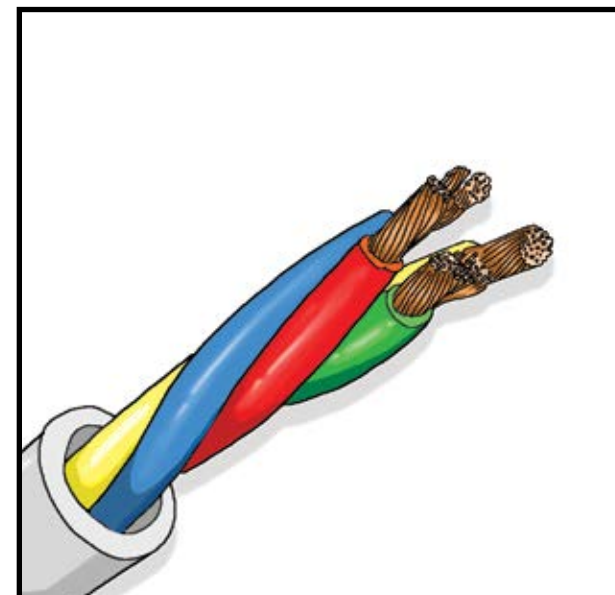
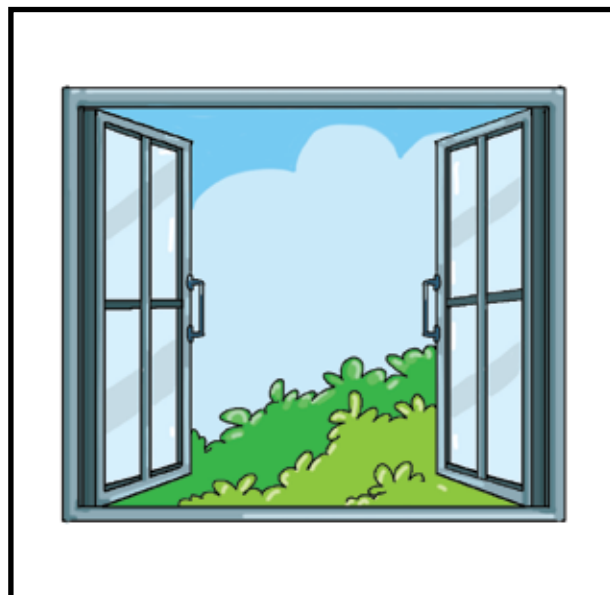
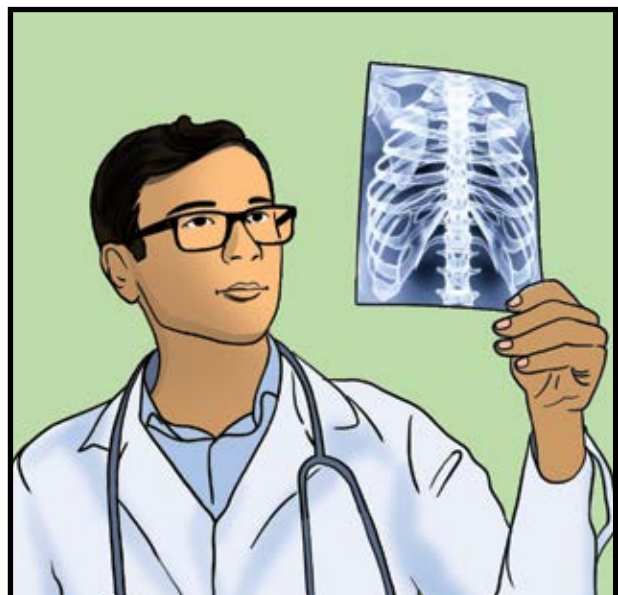

W

X

Y

W

X

y



# Accelerated Adult Learning - Basic Literacy

## Lesson 27

### Yarn

Name the letter and its sound.

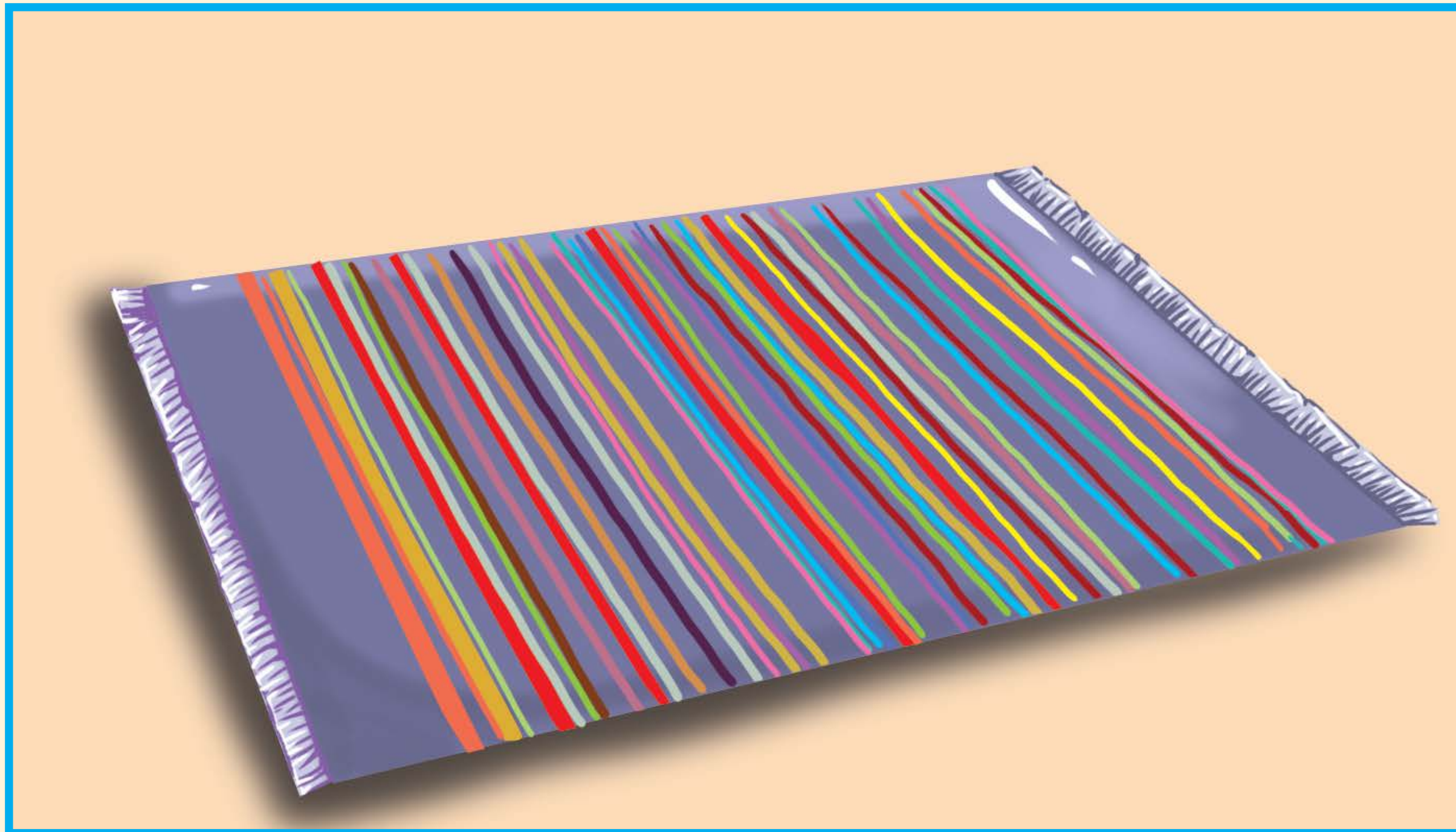

They make **y**arn mats.

yarn

y

Y

Name the pictures and match them with the letters.

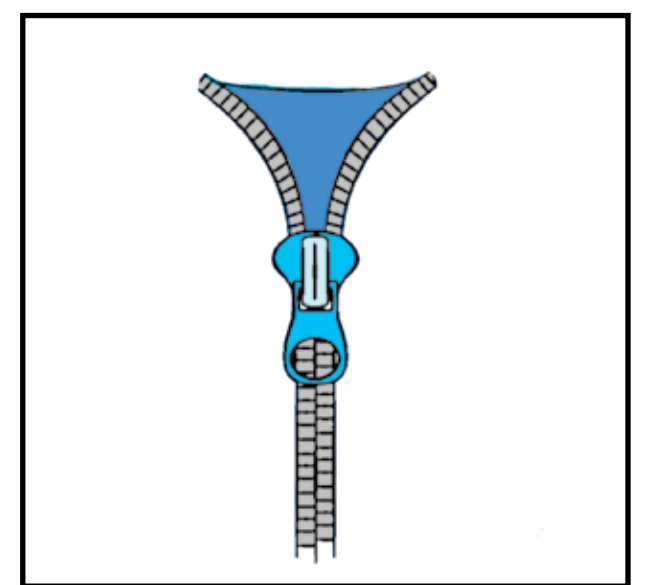
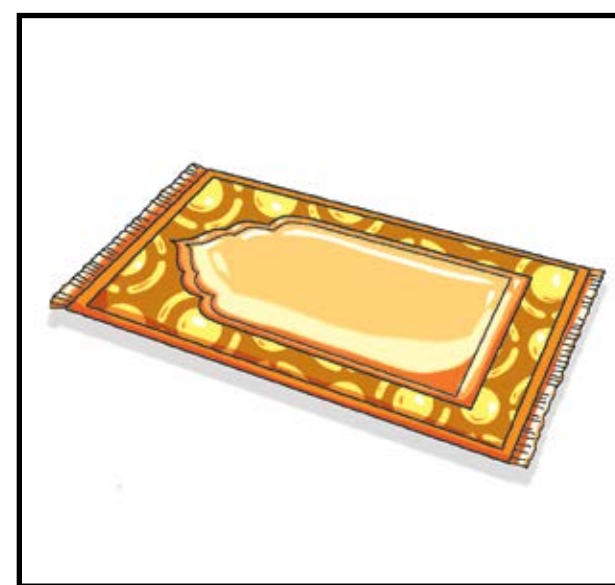
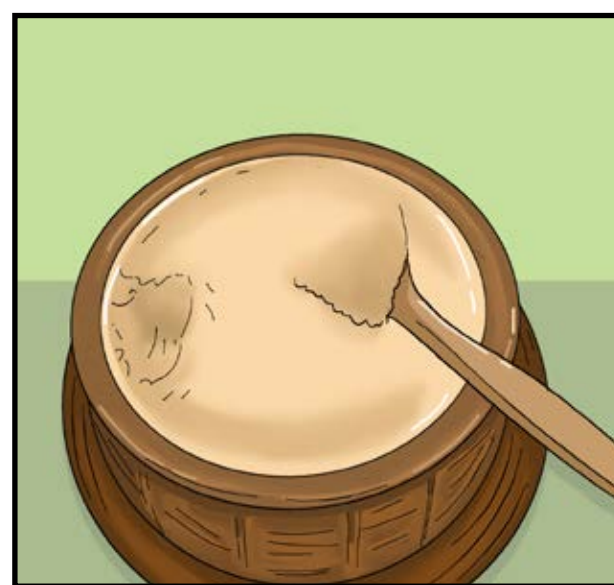
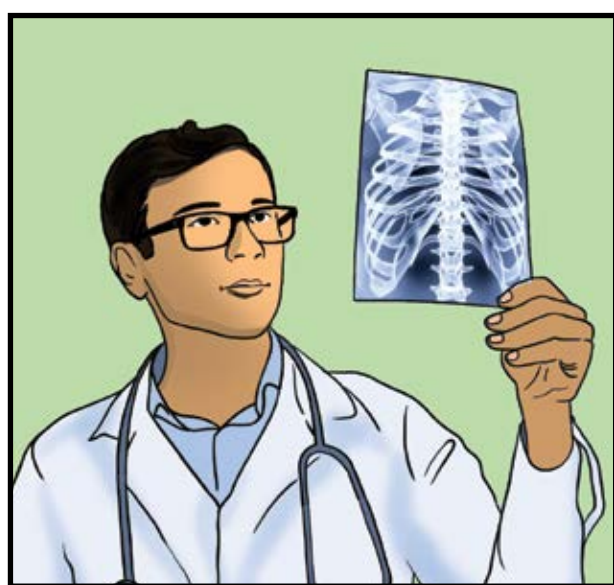
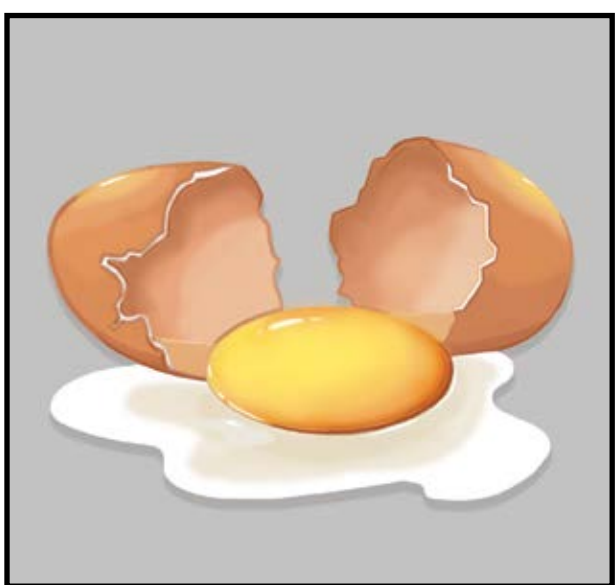

X

Y

Z

X

y

Z



# Accelerated Adult Learning - Basic Literacy

## Lesson 28

### Tailoring

Name the letter and its sound.

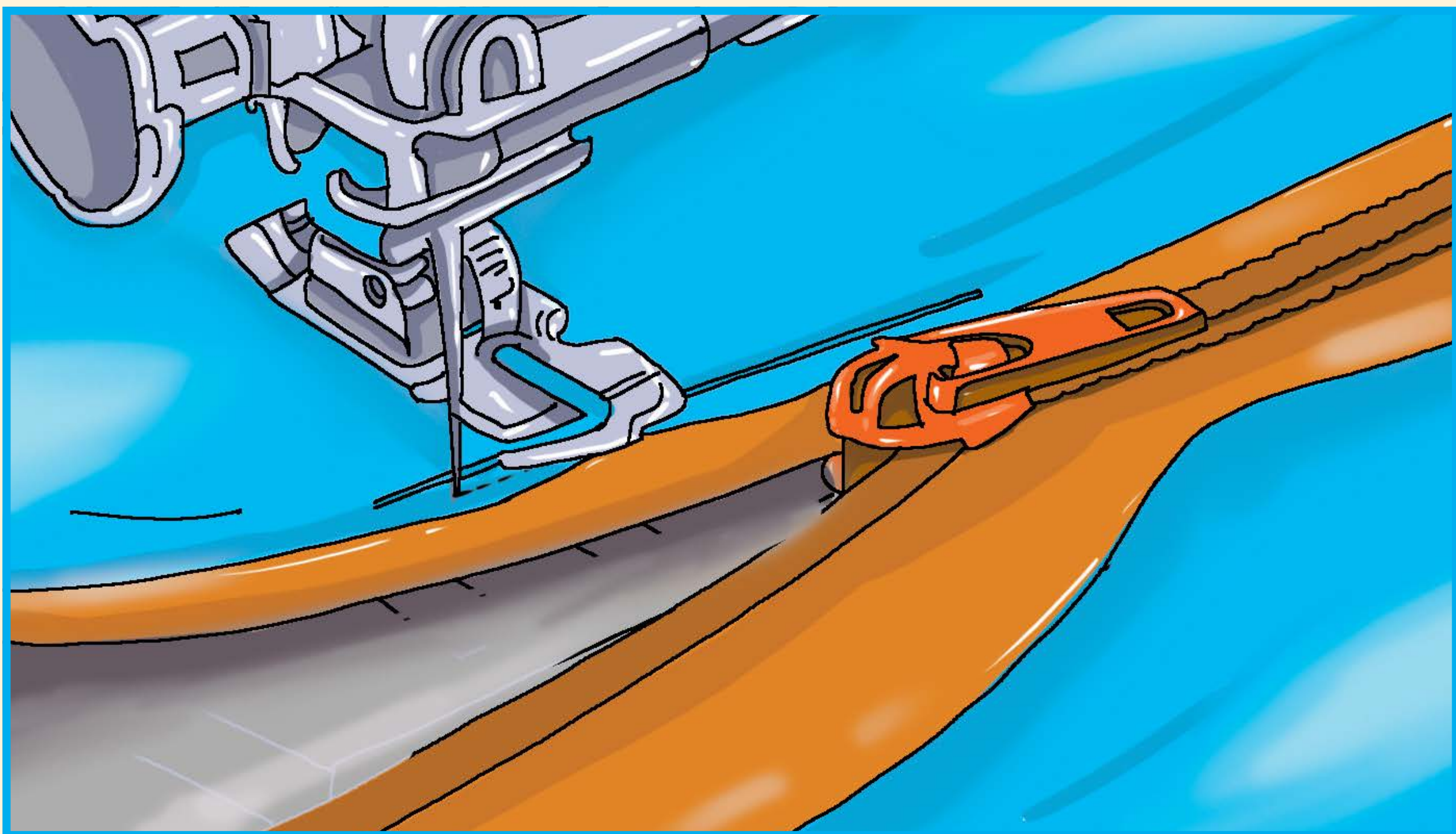

The tailor sewed a zipper.

zipper

z

Z

Name the pictures and match them with the letters.

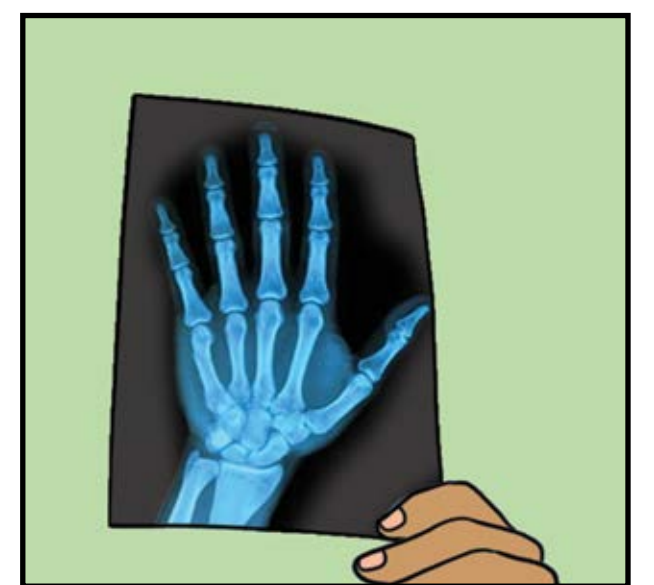
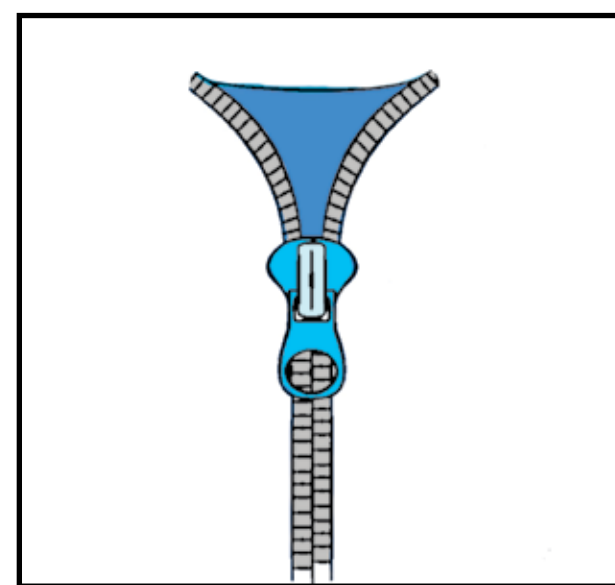
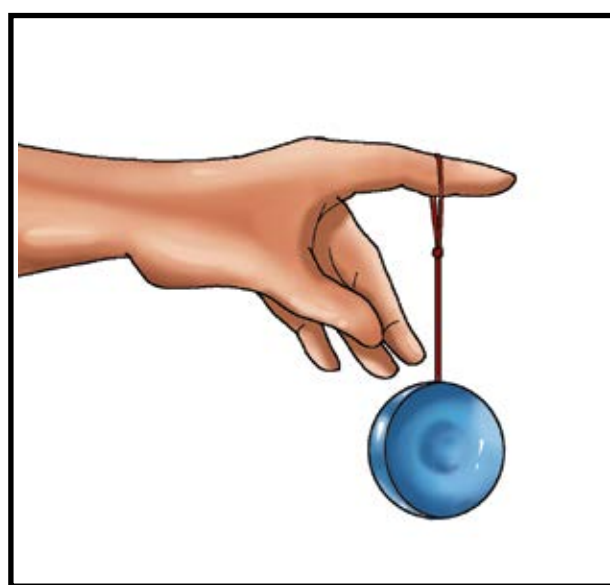
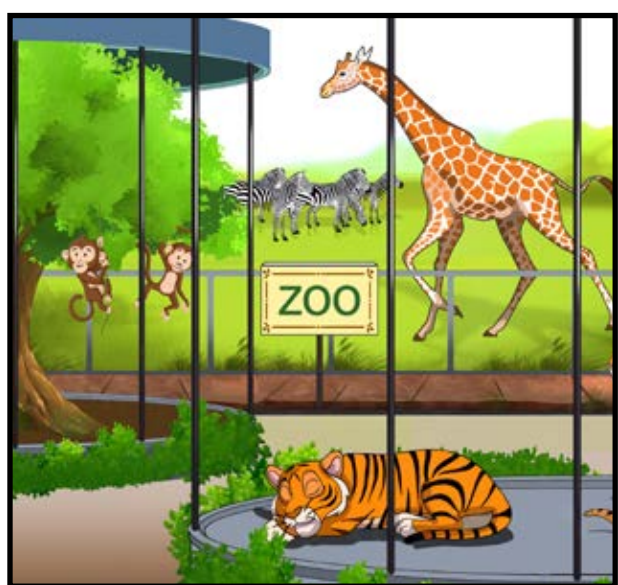

X

Y

Z

X

y

Z



# Accelerated Adult Learning - Basic Literacy

## Lesson 29

### Review

Name the letter and its sound.

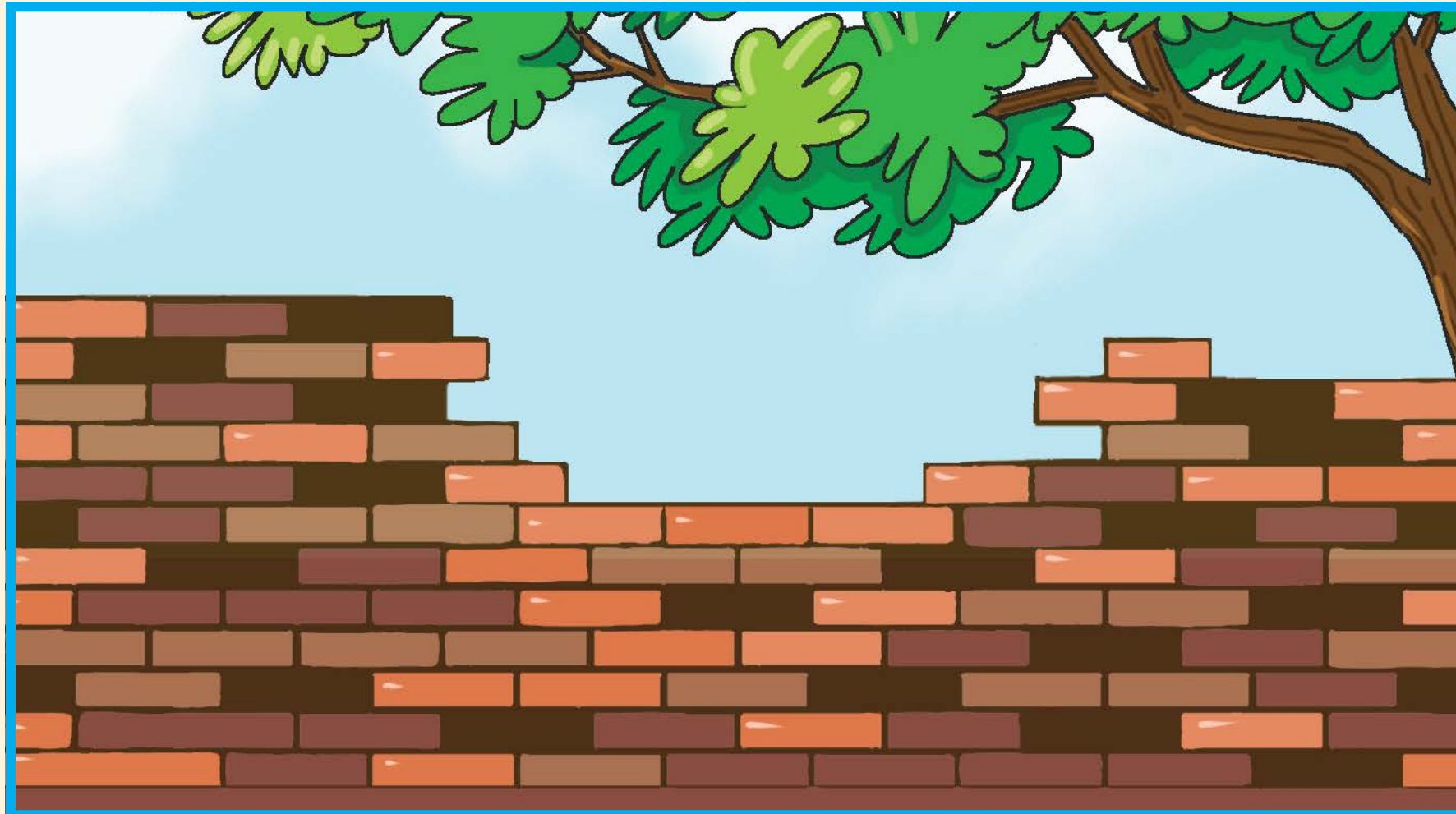

A mason made this wall.

wall			
w	a	l	l
wall			

Name the pictures and match them with the Letters.

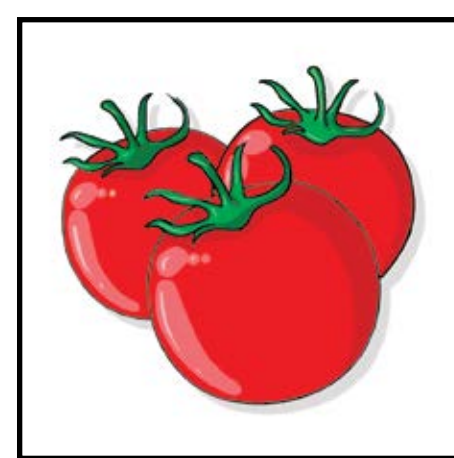
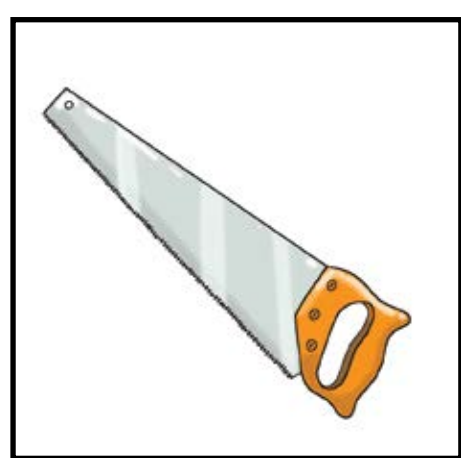

S	T	U	V	S	t	U	V
---	---	---	---	---	---	---	---

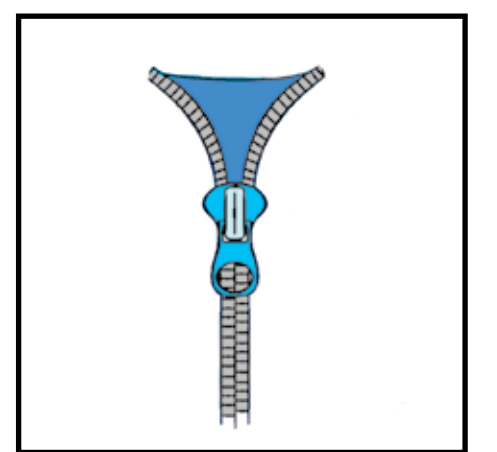
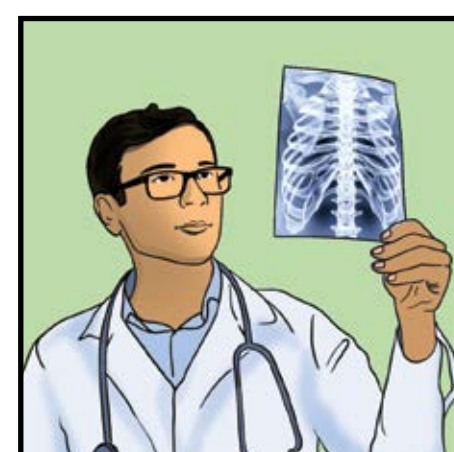
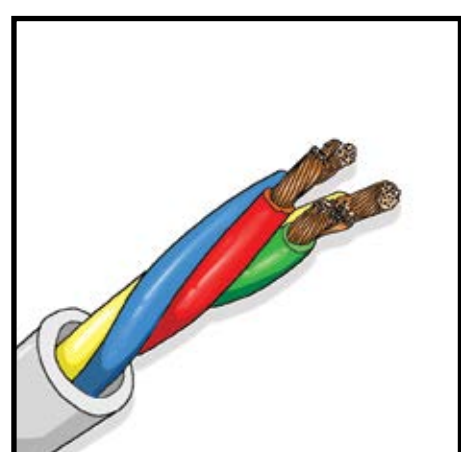

W	X	Y	Z	w	x	y	z
---	---	---	---	---	---	---	---



# Accelerated Adult Learning - Basic Literacy

## Lesson 30

### Review

Name the letter and its sound.



Tailors sew with thread made from **yarn**.

yarn			
y	a	r	n
yarn			

Name the pictures and match them with the Letters.

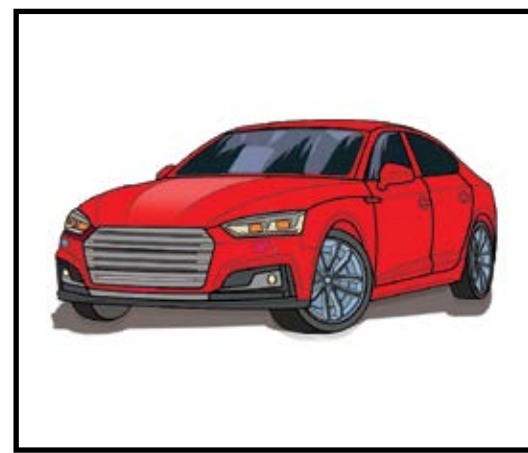
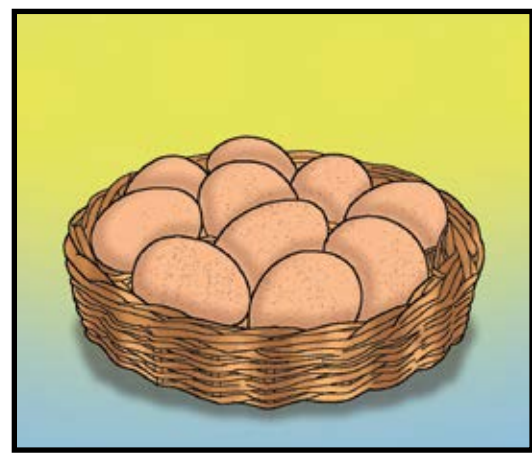

A	B	C	D	E	a	b	c	d	e
---	---	---	---	---	---	---	---	---	---

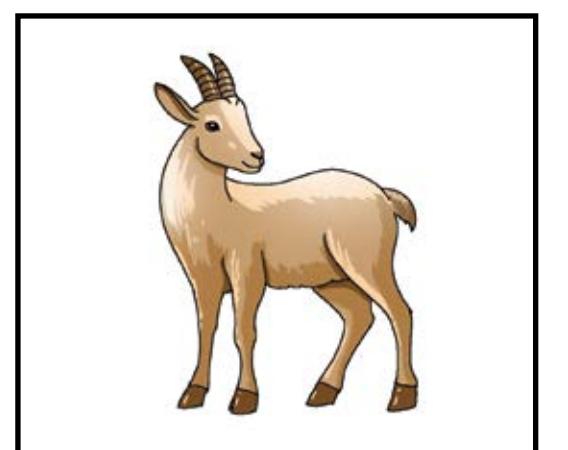
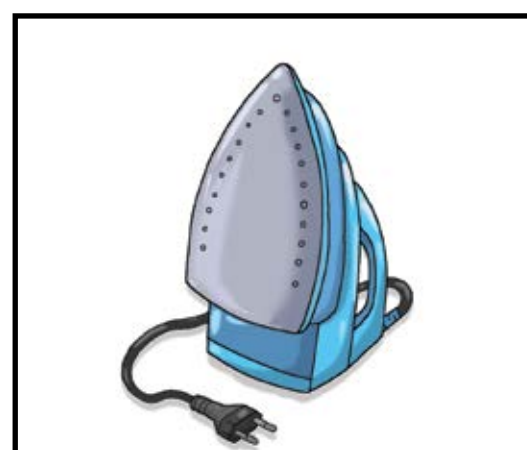
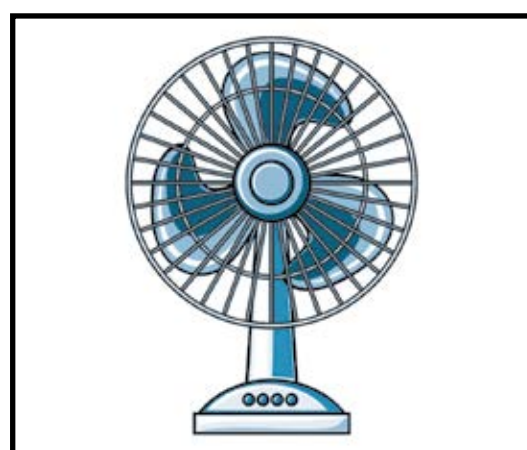

F	G	H	I	f	g	h	i
---	---	---	---	---	---	---	---



# Accelerated Adult Learning (Basic Literacy) **Lesson 31-40** Flipchart



**ISEC** 

Improving Skills and  
Economic Opportunities  
for Cox's Bazar



# Accelerated Adult Learning - Basic Literacy

## Lesson 31 Measurement

Name the letter and its sound.

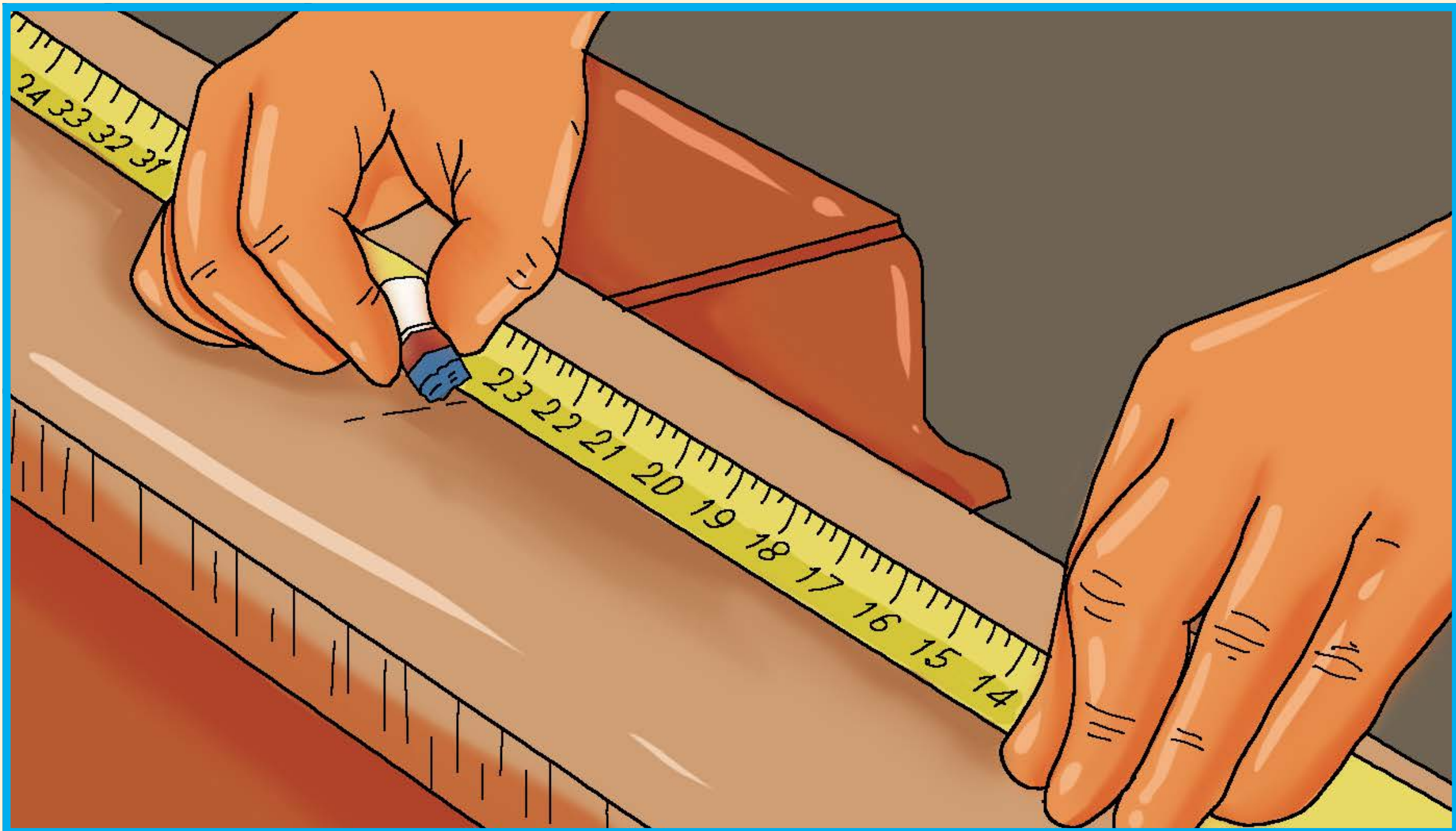

I use a **tape** to measure.

tape

a

A

Name the pictures and match them with the words.

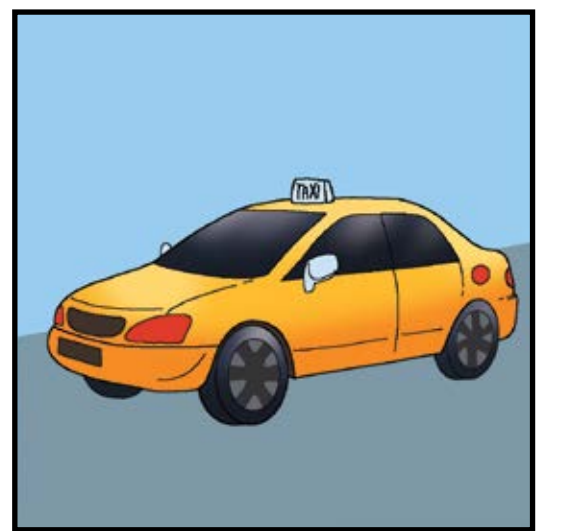
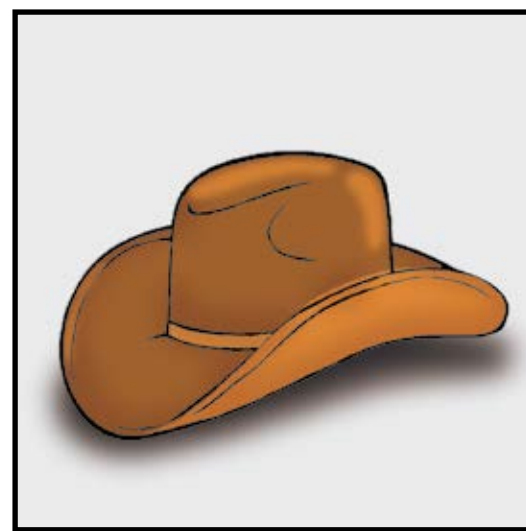
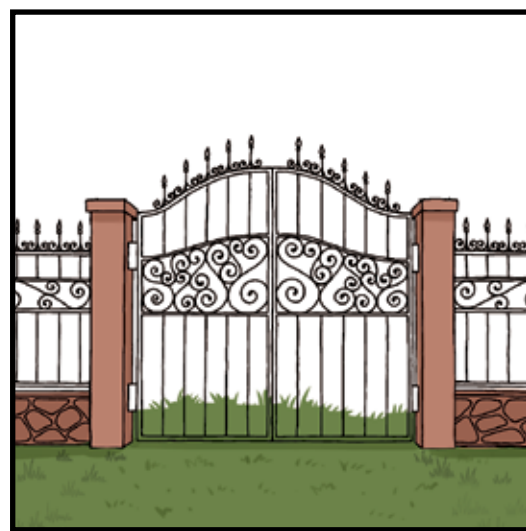
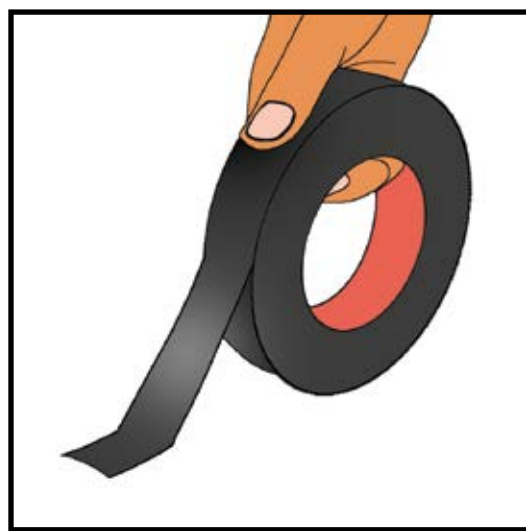

cab

hat

bat

gate

tape

rain



# Accelerated Adult Learning - Basic Literacy

## Lesson 32

### Safety First

Name the letter and its sound.



The **meter** is by the door.

meter

e

E

Name the pictures and match them with the words.

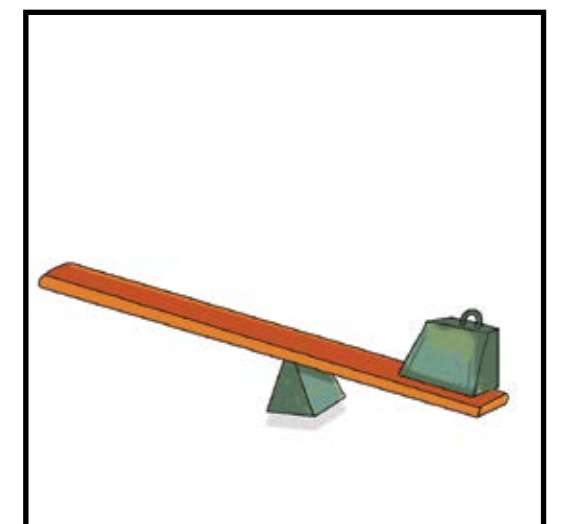
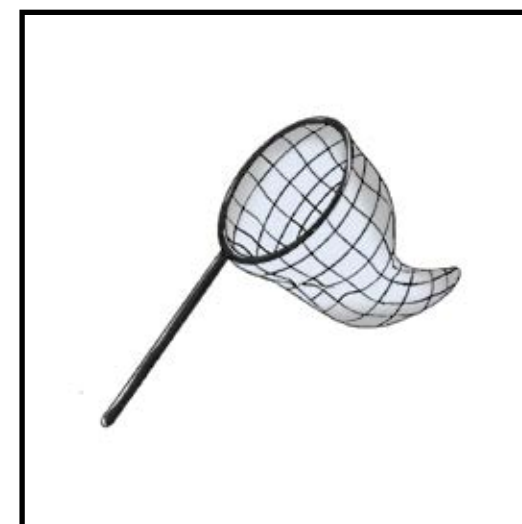
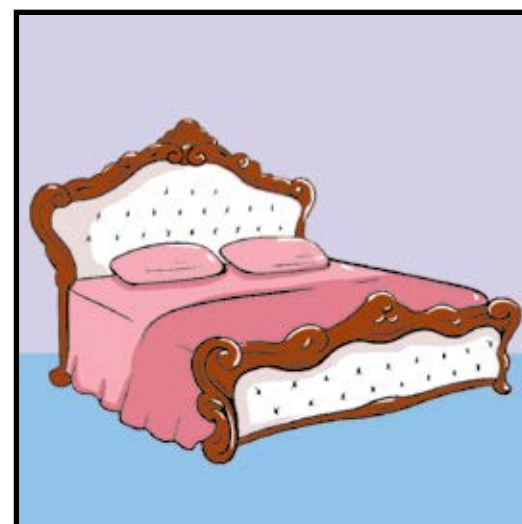
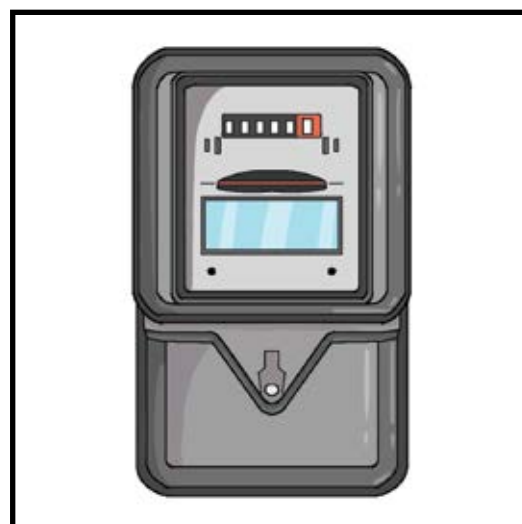
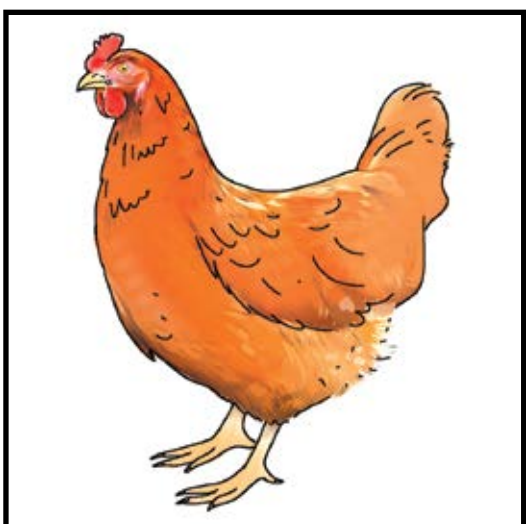

bed

net

hen

meter

lever

leaf



# Accelerated Adult Learning - Basic Literacy

## Lesson 33 Natural Pesticides

Name the letter and its sound.

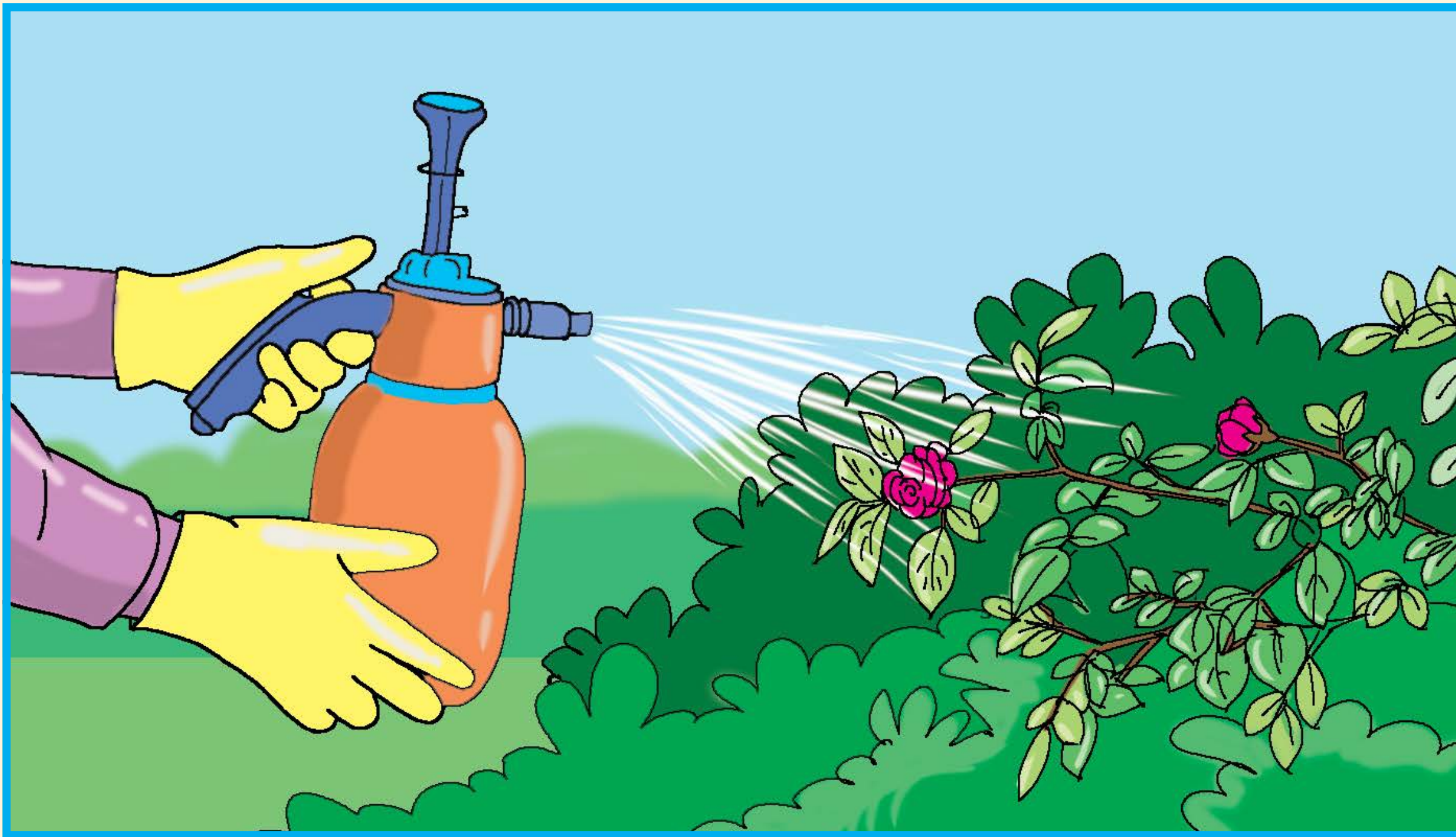

We protect our plants from **insects**.

insects

i  
i

Name the pictures and match them with the words.

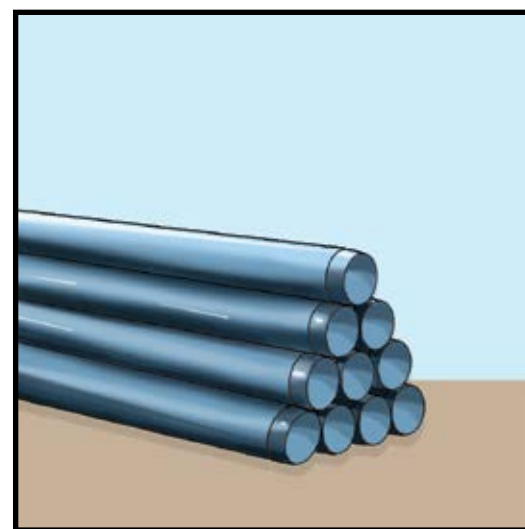
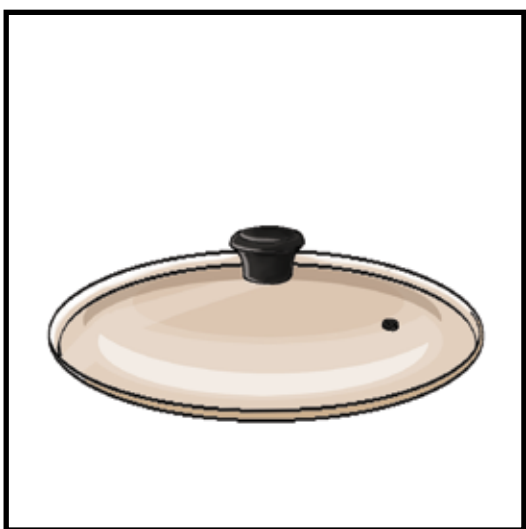

ink

insects

lid

iron

bike

pipe



# Accelerated Adult Learning - Basic Literacy

## Lesson 34

### Soap Making

Name the letter and its sound.



We wash with **s**oap.

s o a p

o

o

Name the pictures and match them with the words.

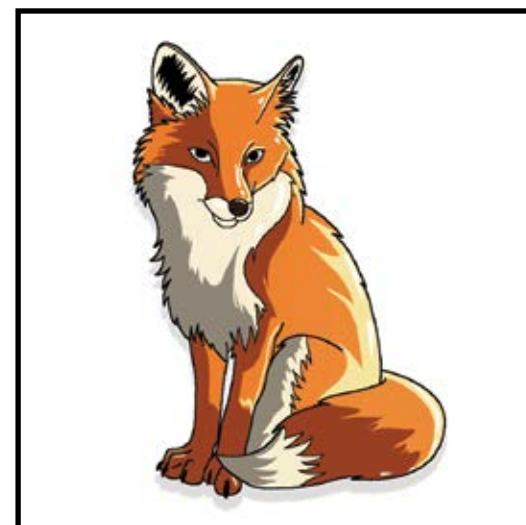
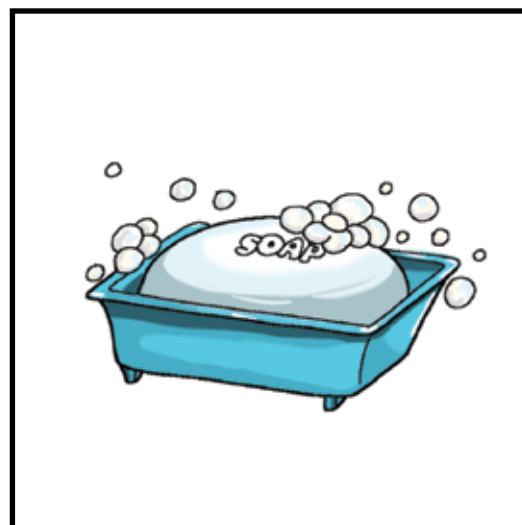
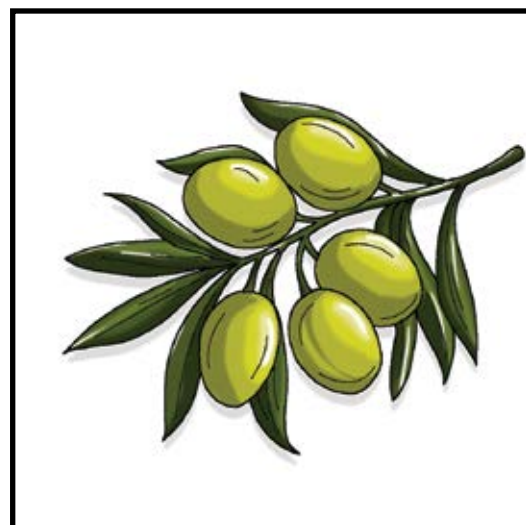

o live

b o x

f o x

r o p e

c o a t

s o a p



# Accelerated Adult Learning - Basic Literacy

## Lesson 35 Flower Making

Name the letter and its sound.



I can make tulips with cloth.

tulips  
u  
u

Name the pictures and match them with the words.

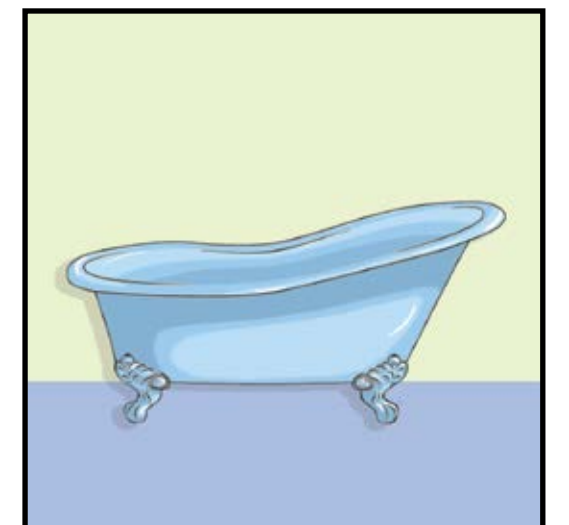
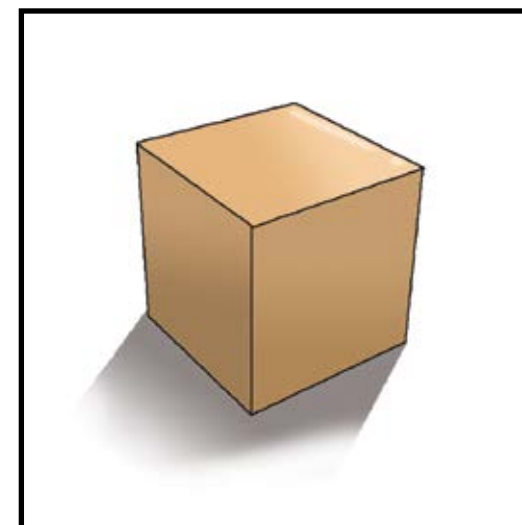
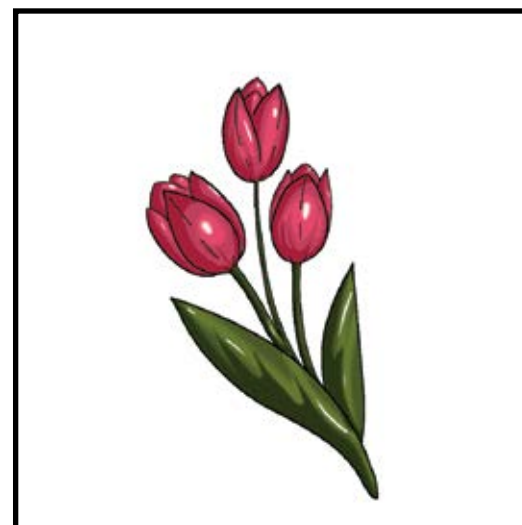
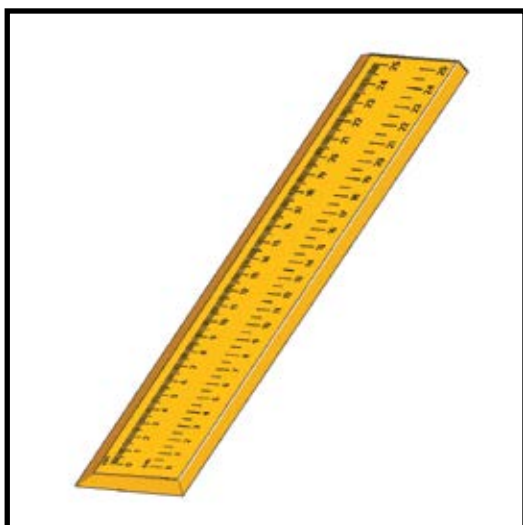

mug

bud

tub

cube

tulips

ruler



# Accelerated Adult Learning - Basic Literacy

## Lesson 36 Natural Dyes

Name the letter and its sound.



I will **dye** a shirt for the **boy**.

dye  
y  
Y

boy  
y  
Y

Name the pictures and match them with the words.

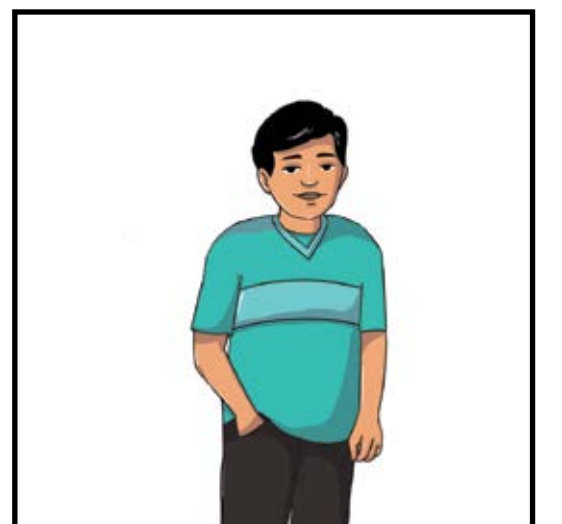
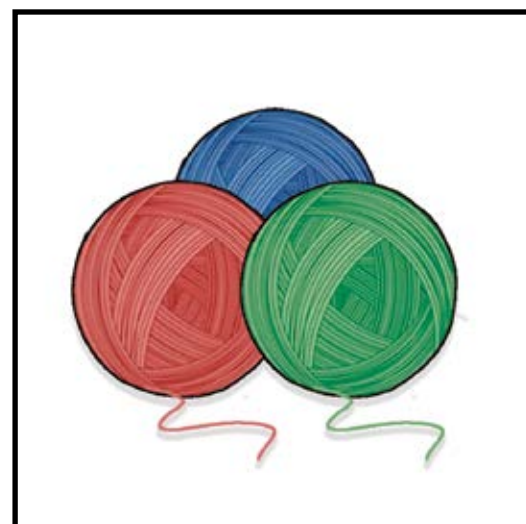
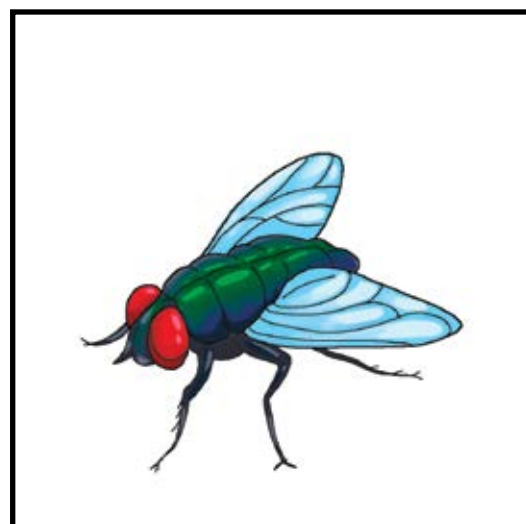

fly

shy

yarn

toy

boy

nylon



# Accelerated Adult Learning - Basic Literacy

## Lesson 37

### Selling Ornaments

Name the letter and its sound.



Mother gave me a **chain**.

chain  
ch  
CH

Name the pictures and match them with the words.

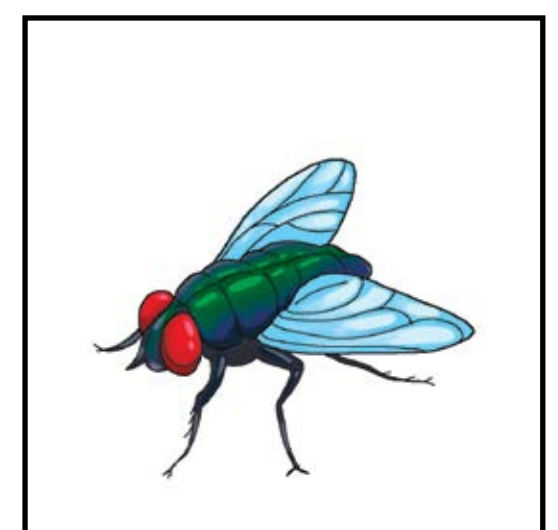
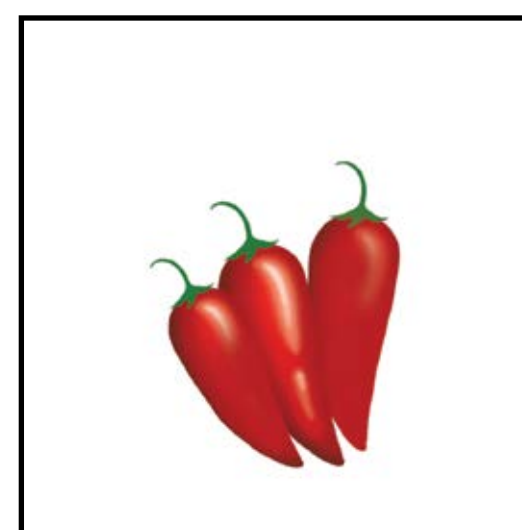
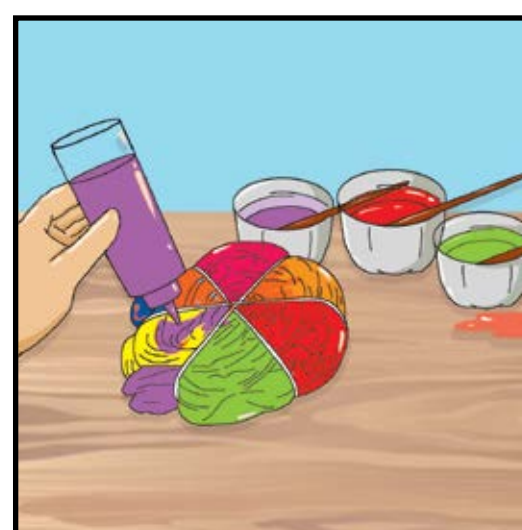
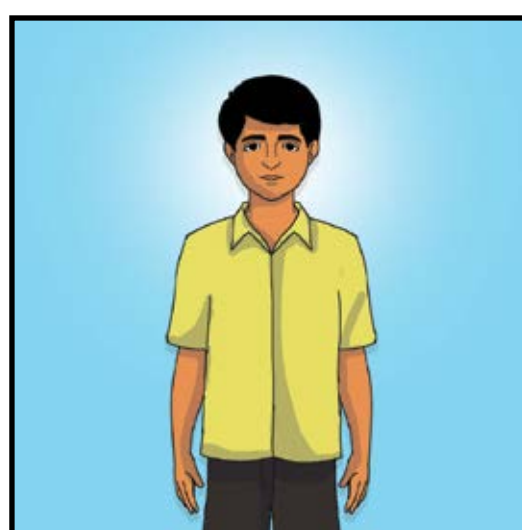
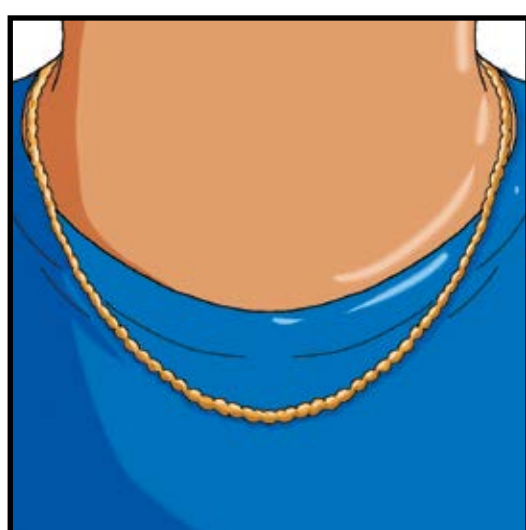
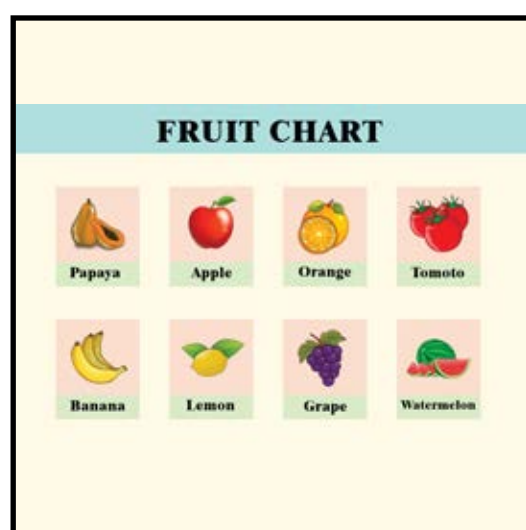

chart

chili

chain

fly

dye

boy



# Accelerated Adult Learning - Basic Literacy

## Lesson 38 Photo Frames

Name the letter and its sound.



I have a frame for my **photo**.

photo  
ph  
PH

Name the pictures and match them with the words.

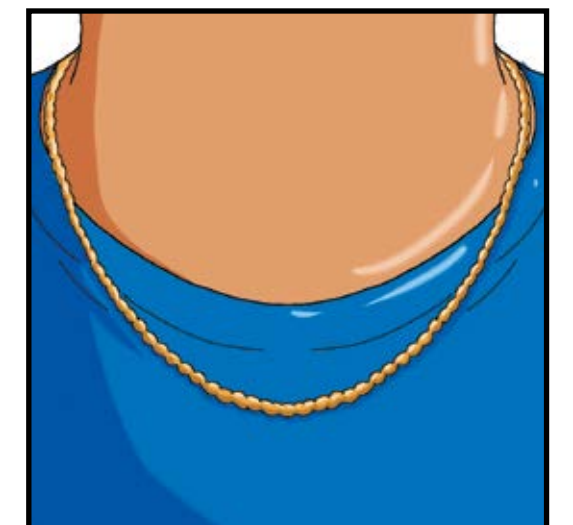
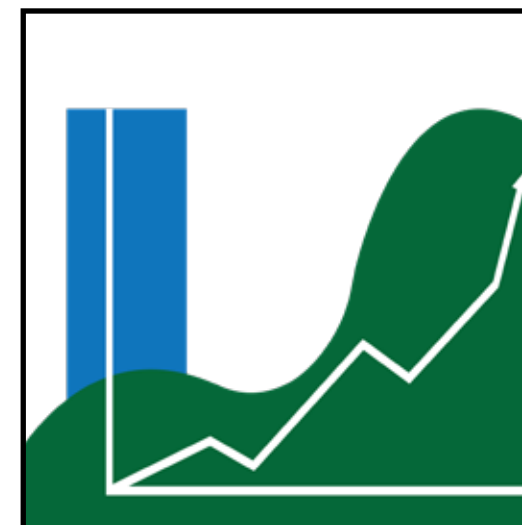
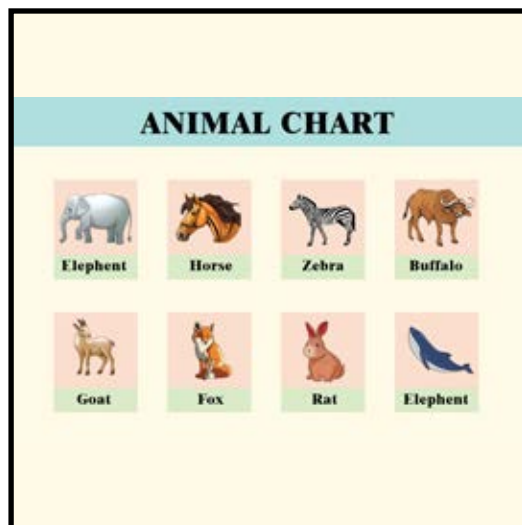

photo

phone

chart

chain

graph

chilli



# Accelerated Adult Learning - Basic Literacy

## Lesson 39

### Shapes

Name the letter and its sound.

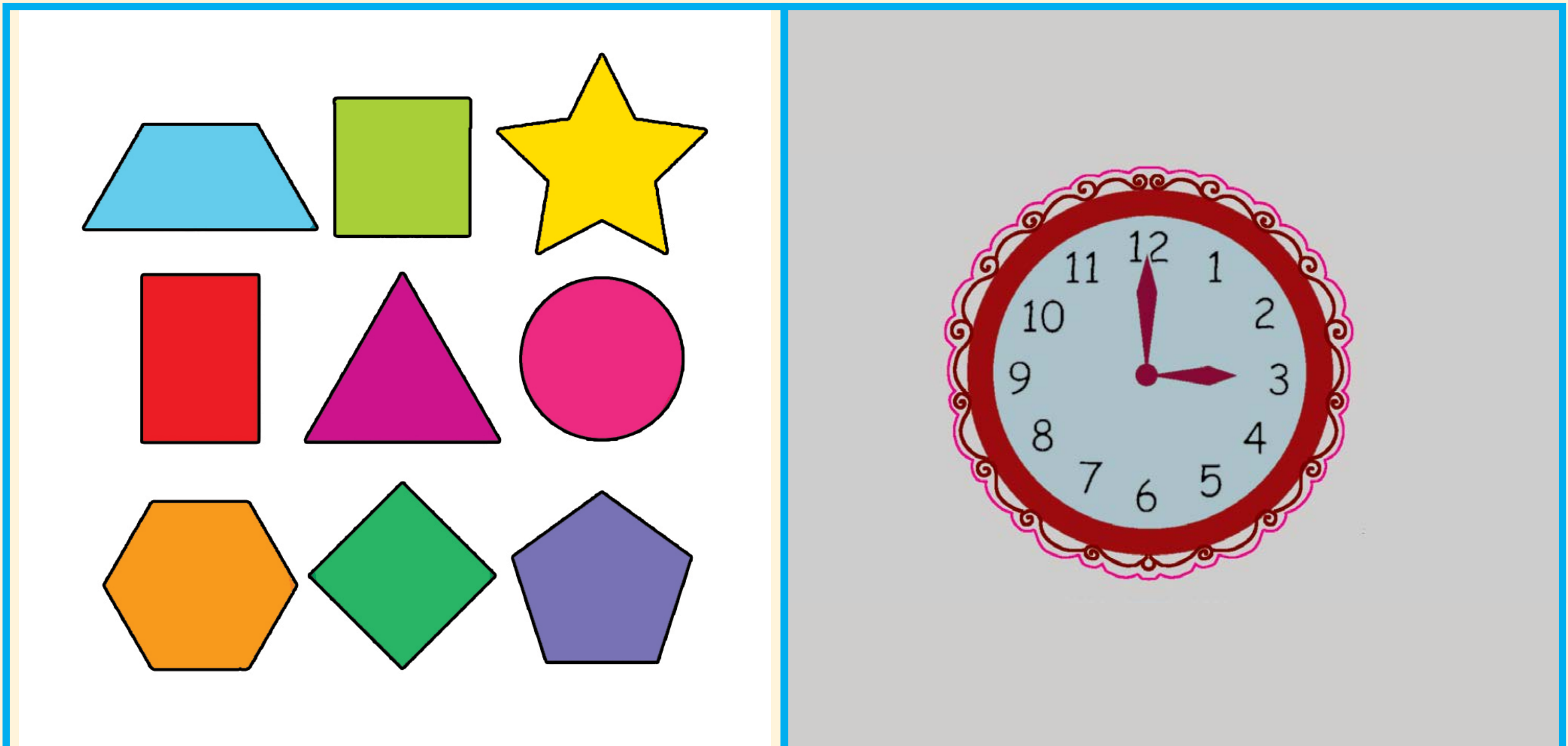

The clock has a round **shape**.

shape  
sh  
SH

Name the pictures and match them with the words.

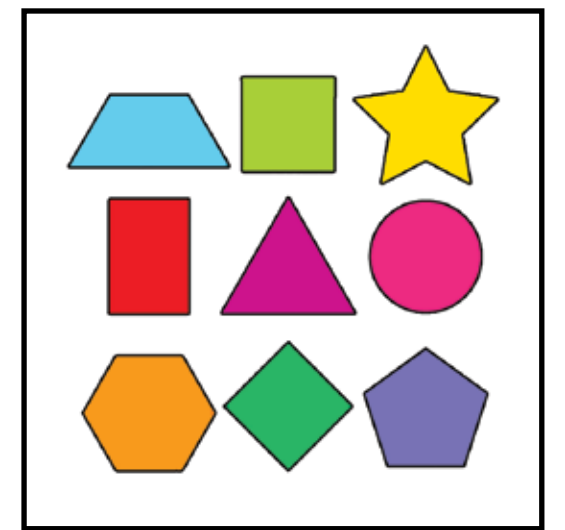
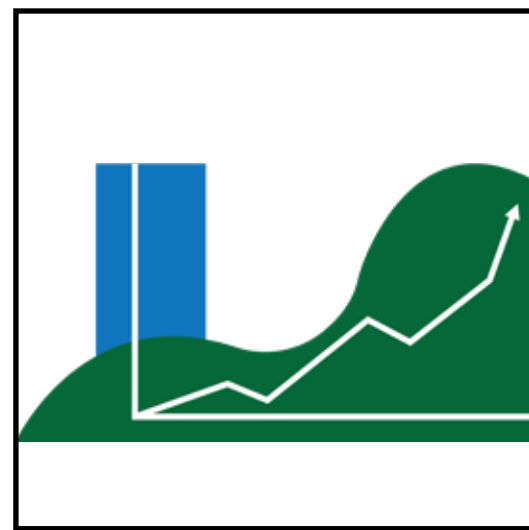
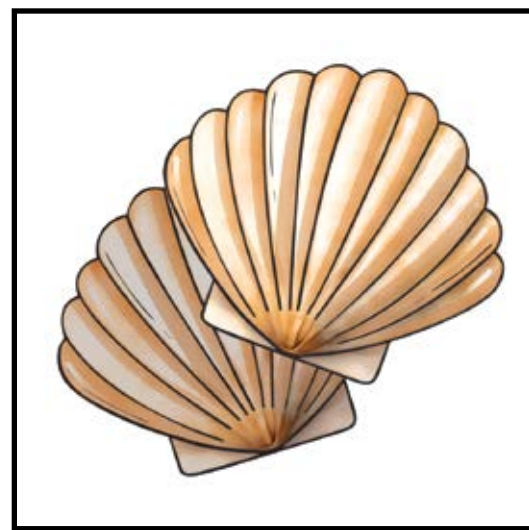

shell

shape

shirt

photo

phone

graph



# Accelerated Adult Learning - Basic Literacy

## Lesson 40

### Review

Name the letter and its sound.

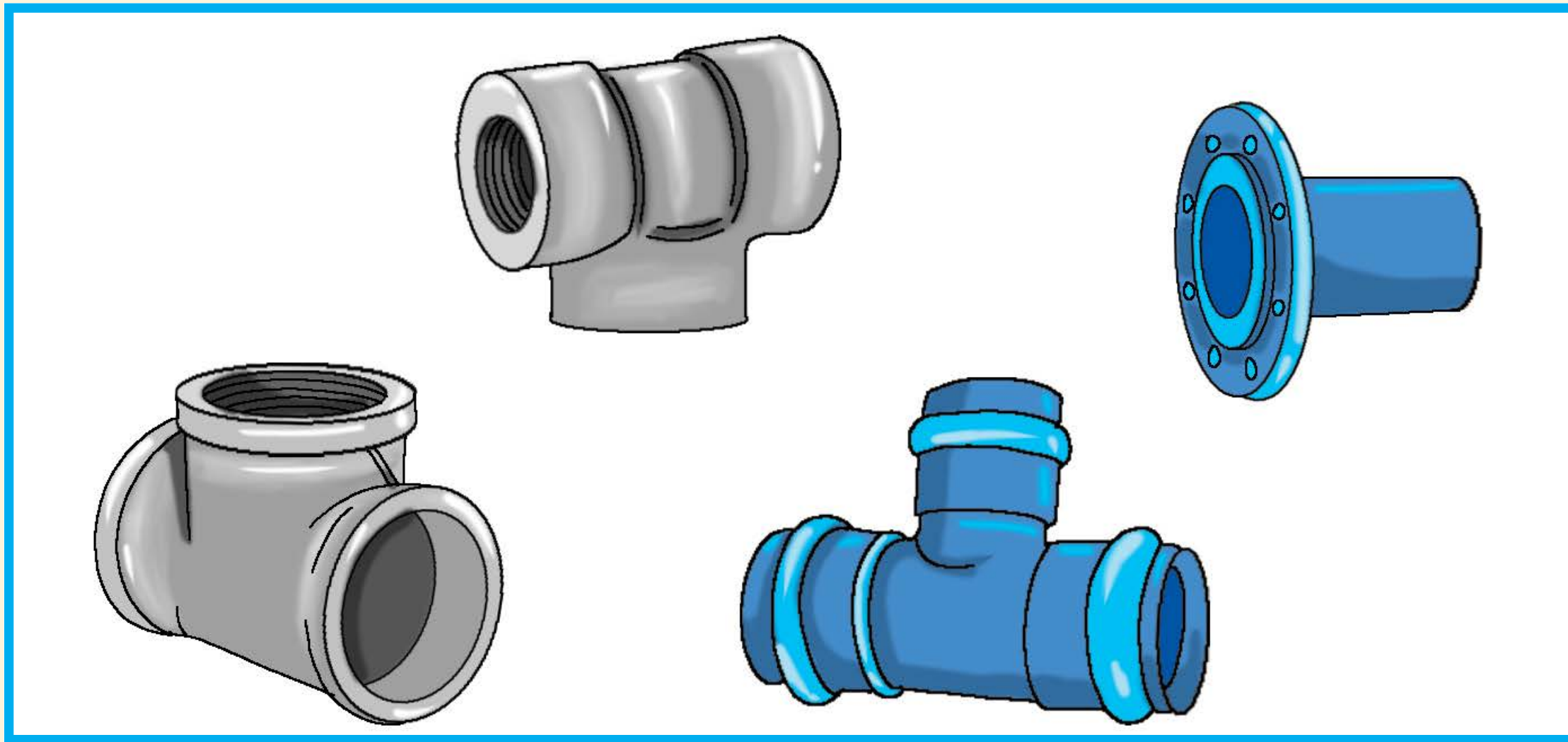

There are many **types** of pipes.

types

y

Y

Name the pictures and match them with the words.

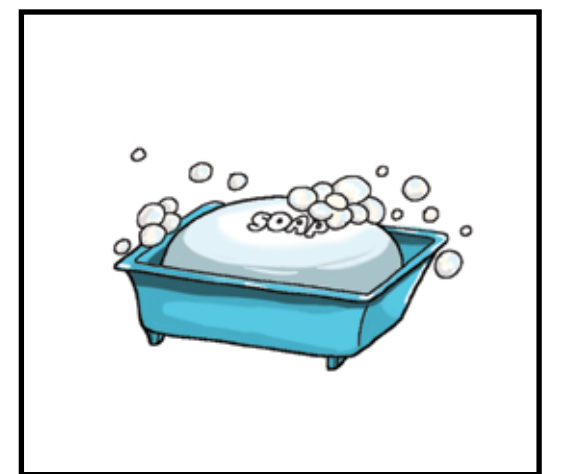
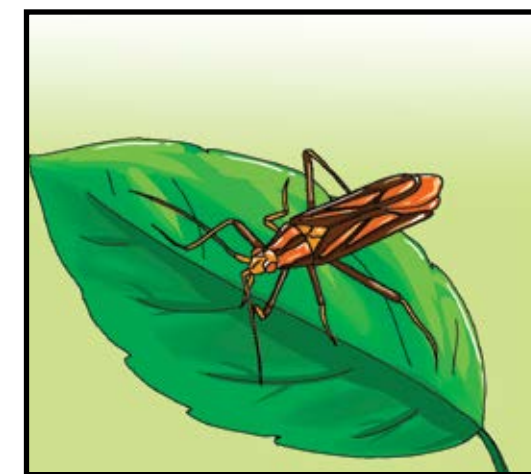
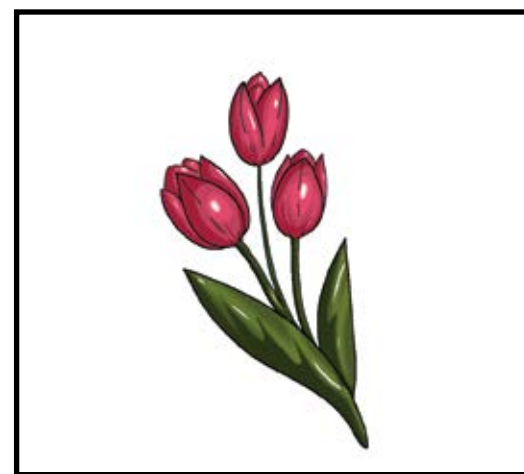
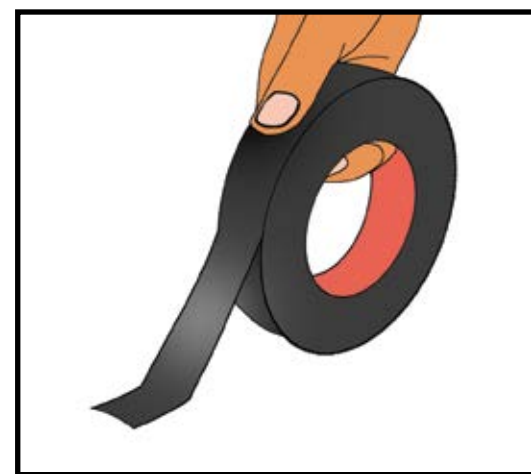
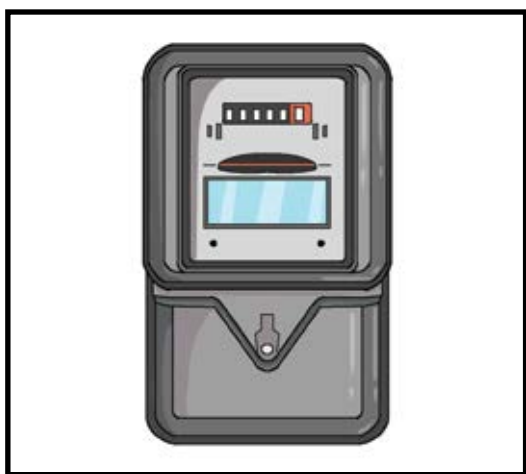

tape

meter

insects

soap

tulip

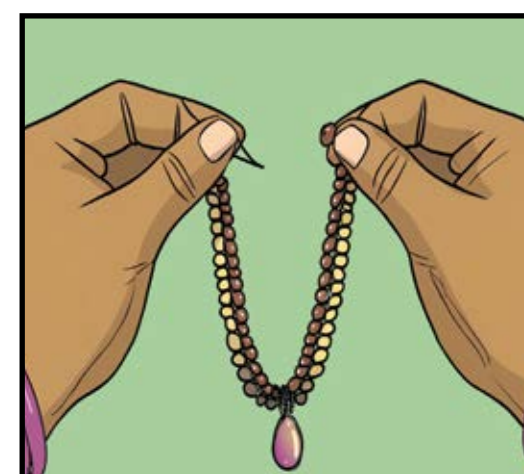
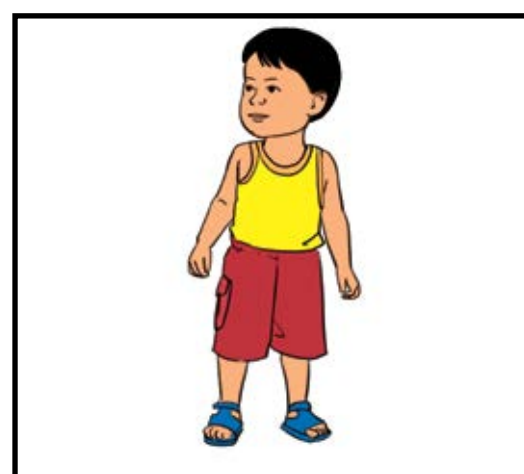
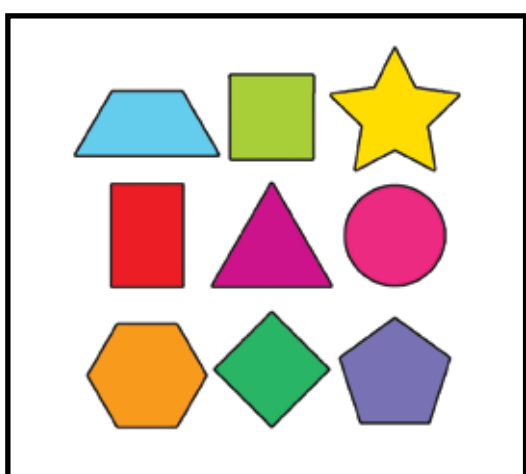

boy

chain

photo

shape



# Accelerated Adult Learning (Basic Literacy) **Lesson 41-50** Flipchart



**ISEC** 

Improving Skills and  
Economic Opportunities  
for Cox's Bazar



# Accelerated Adult Learning - Basic Literacy

## Lesson 41

### Thin and Thick

Name the letter and its sound.

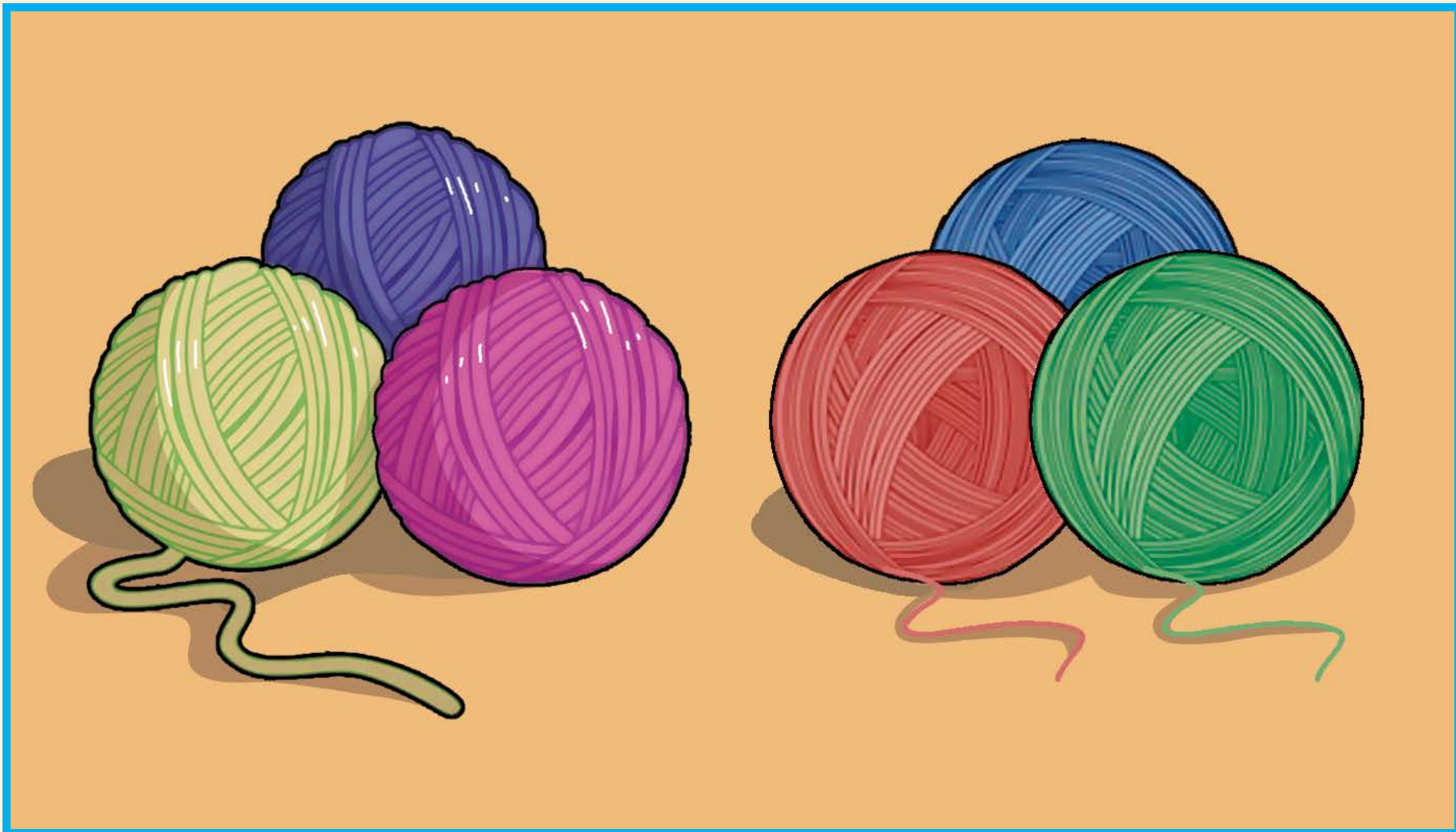

Mother uses **thin** and thick wool.

thin  
th  
TH

Name the pictures and match them with the words.

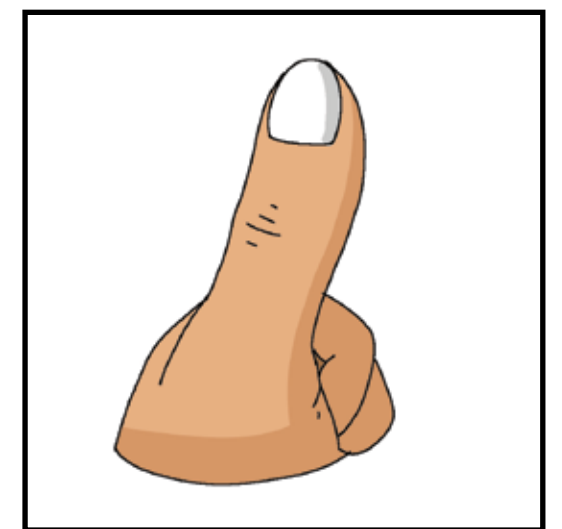
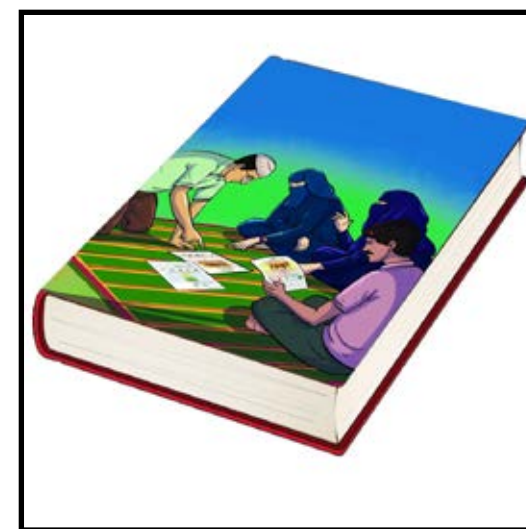
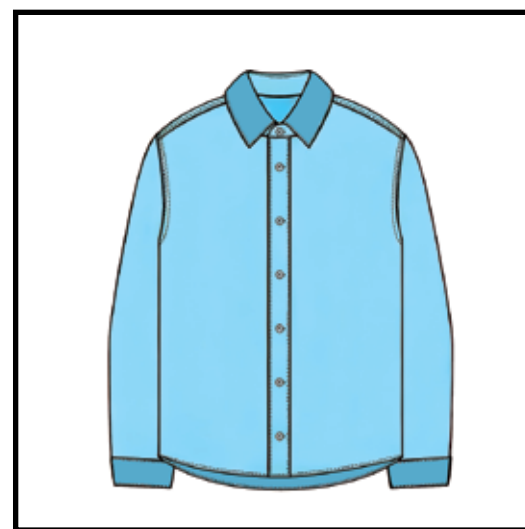
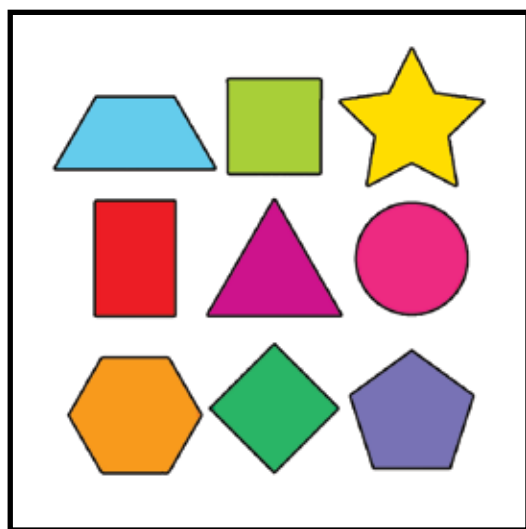
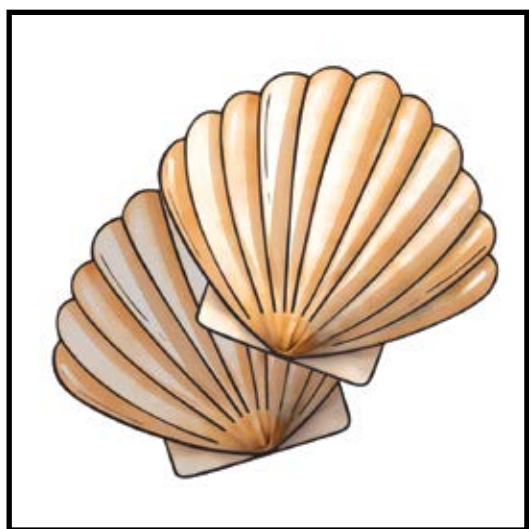

thick

thin

thumb

shape

shell

shirt



# Accelerated Adult Learning - Basic Literacy

## Lesson 42

### Mechanics

Name the letter and its sound.



The van has three **wheels**.

wheels  
wh  
WH

Name the pictures and match them with the words.

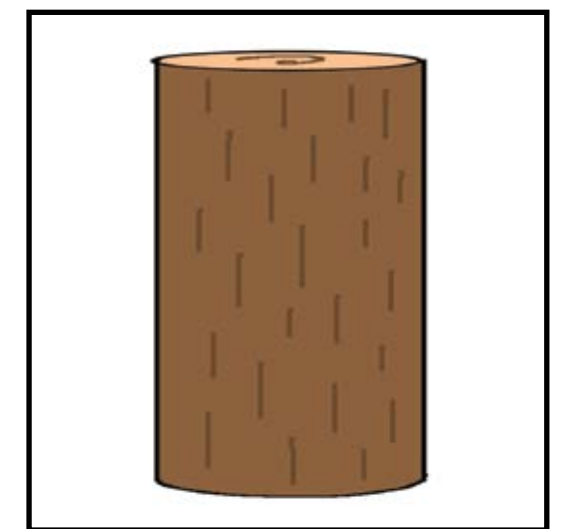
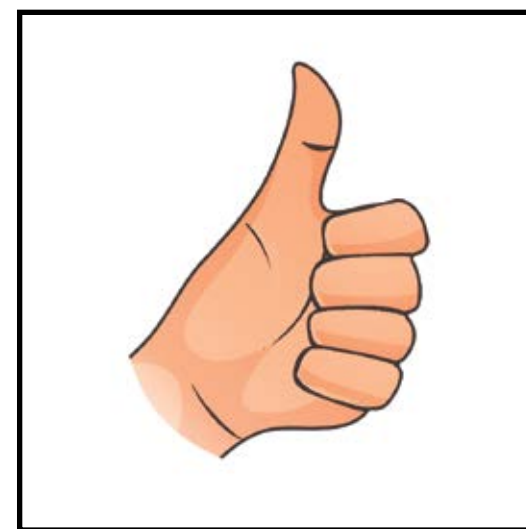
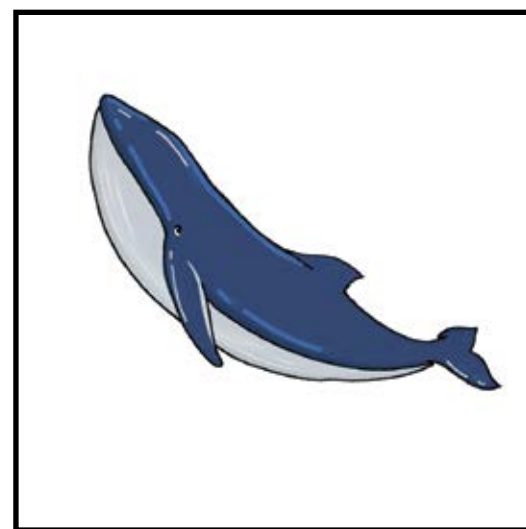
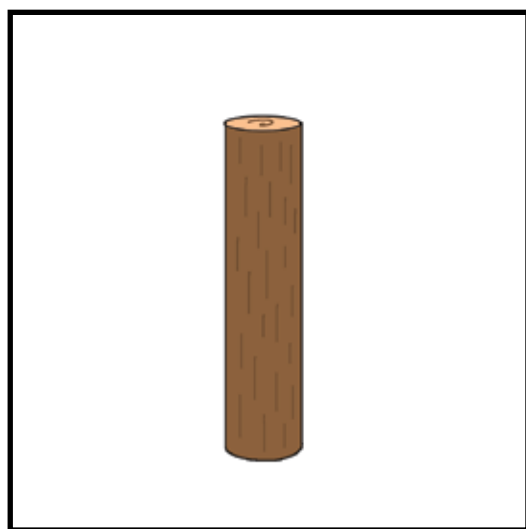
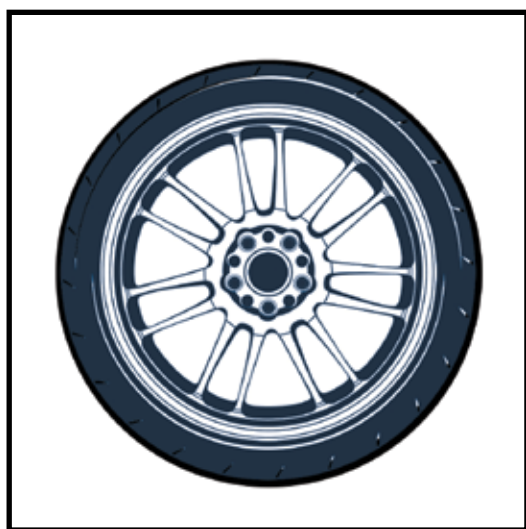

whale

wheat

wheel

thick

thin

thumb



# Accelerated Adult Learning - Basic Literacy

## Lesson 43 Gender Equality

Name the letter and its sound.

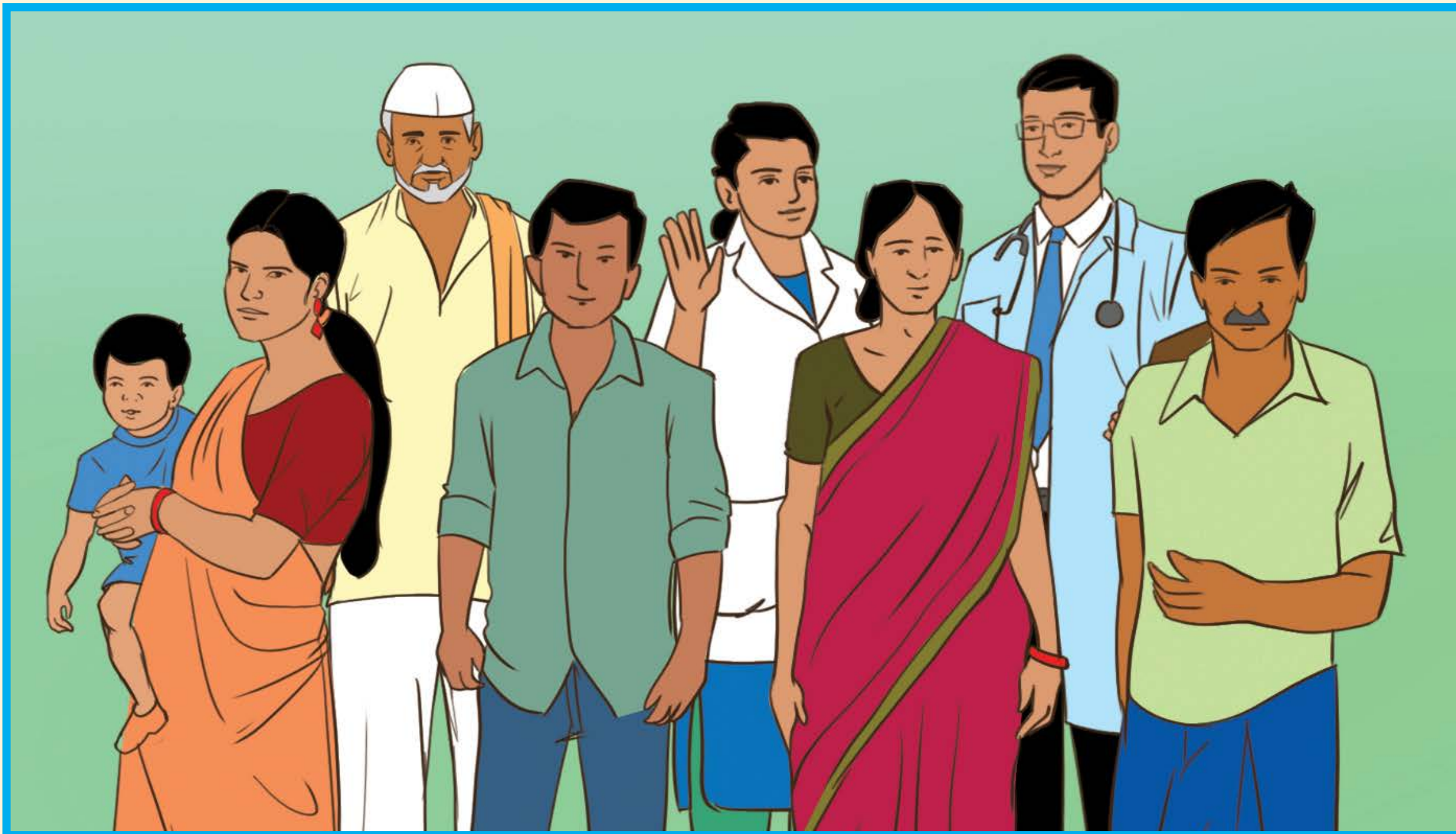

I want to start a business.

business

b

B

Name the pictures and match them with the words.

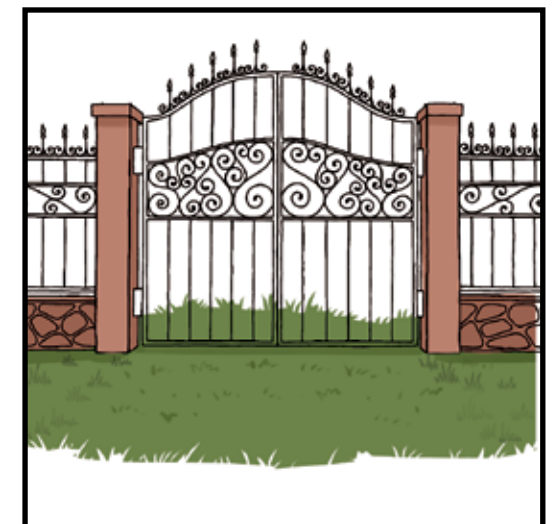
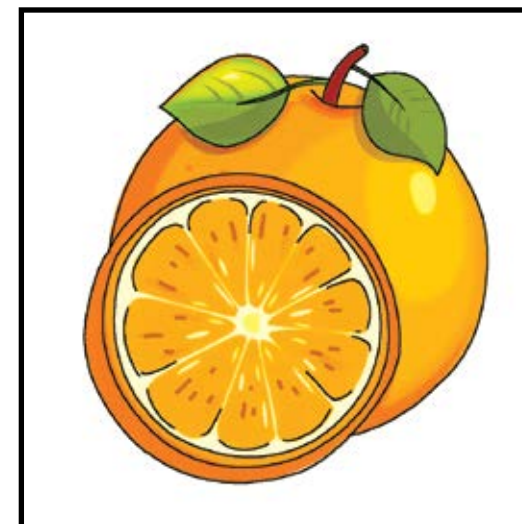
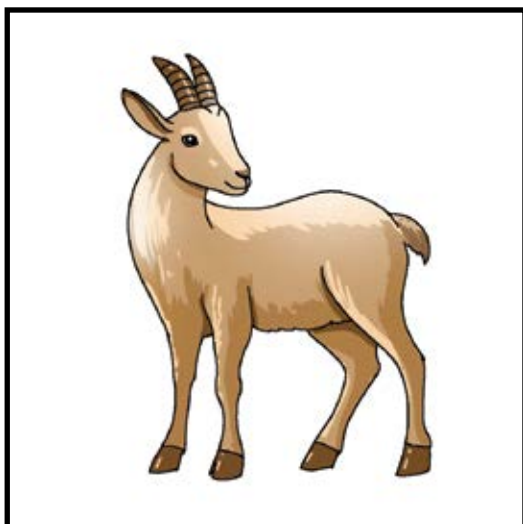
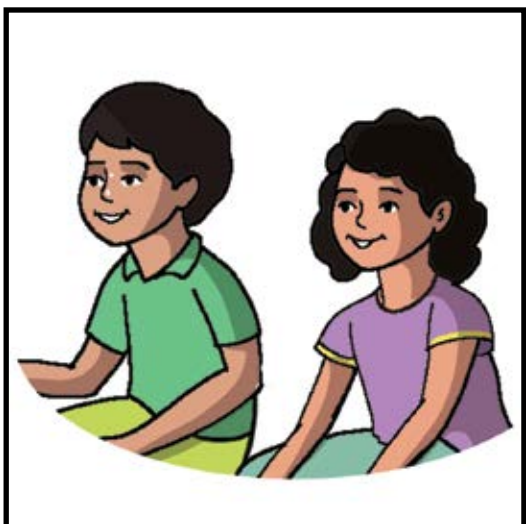

gel

gender

orange

gate

goat

garden



# Accelerated Adult Learning - Basic Literacy

## Lesson 44 Small Businesses

Name the letter and its sound.



I want to start a business.

business

b

B

Name the pictures and match them with the words.

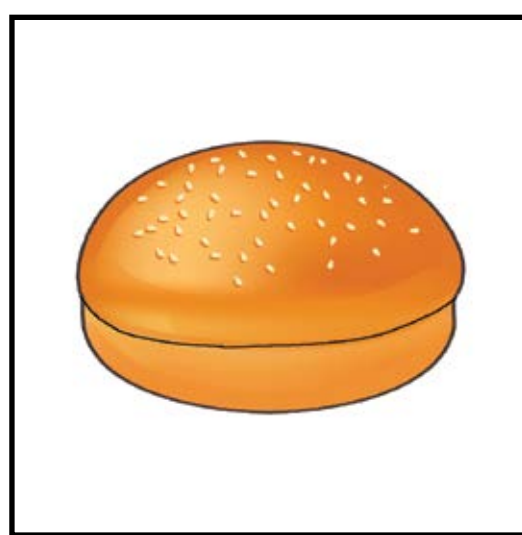
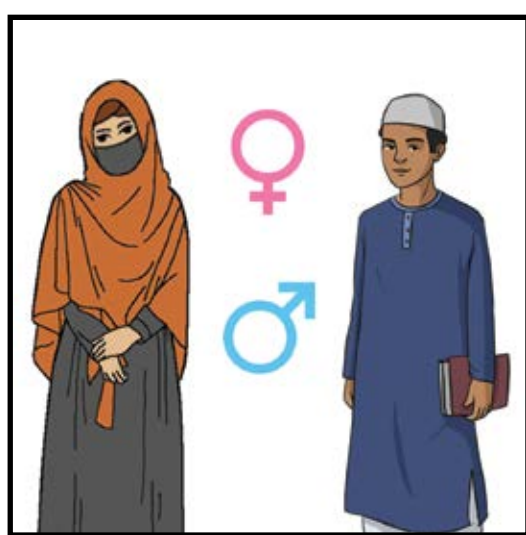

bun

barber

business

gender

gel

page



# Accelerated Adult Learning - Basic Literacy

## Lesson 45 Buying and Selling

Name the letter and its sound.

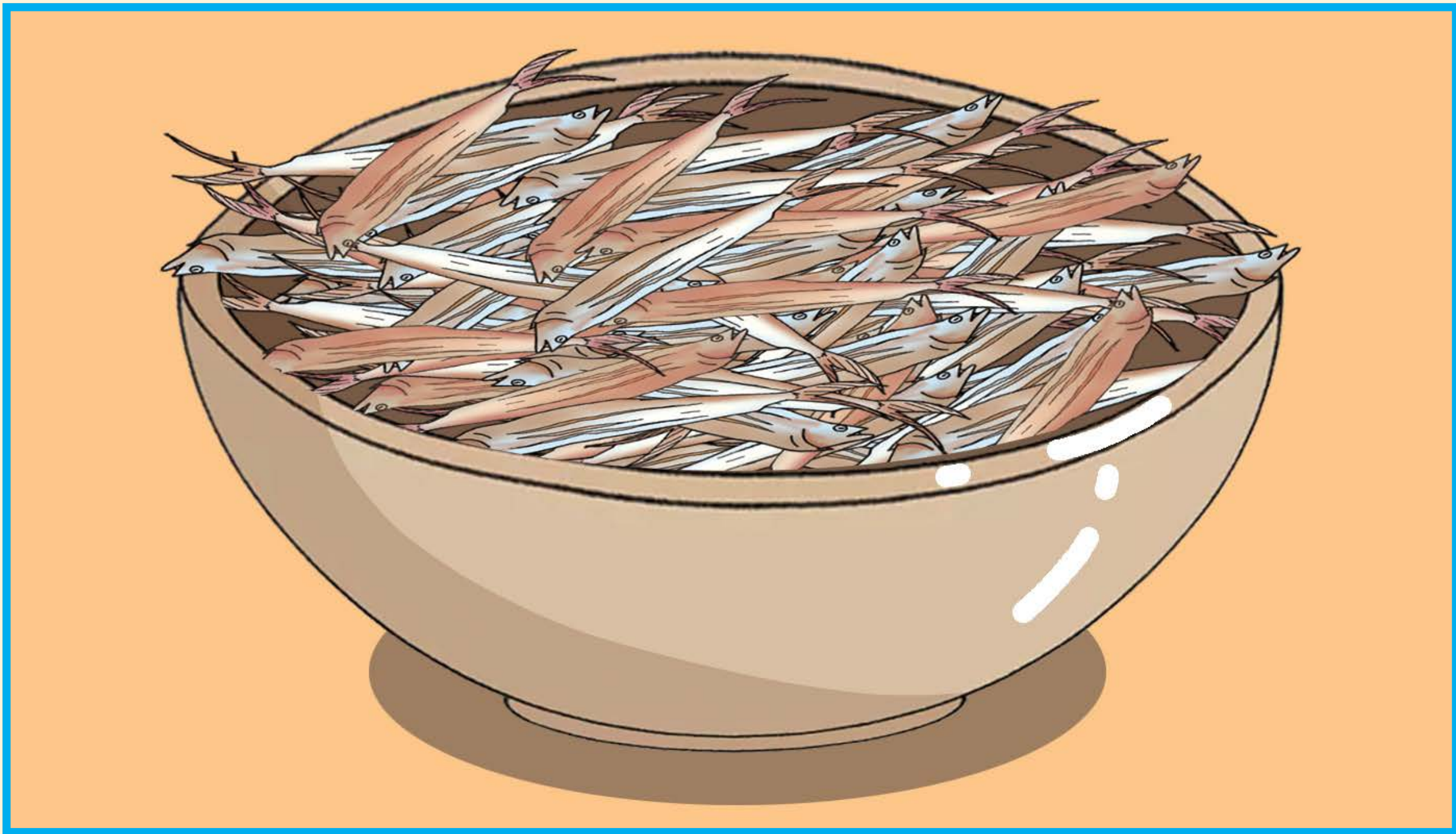

My brother sells **dry** fish.

dry  
d  
D

Name the pictures and match them with the words.

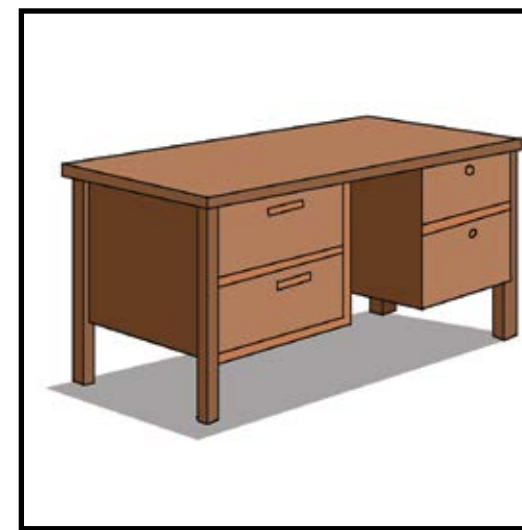
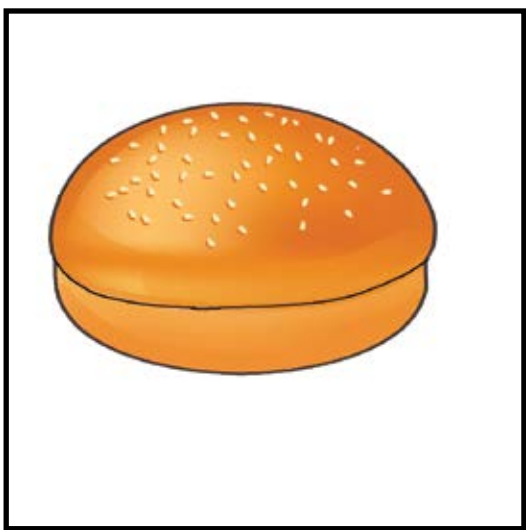

desk

dry

dress

business

bun

barber



# Accelerated Adult Learning - Basic Literacy

## Lesson 46

### Bamboo

Name the letter and its sound.



I made a **fence** with bamboo.

fence

f

F

Name the pictures and match them with the words.

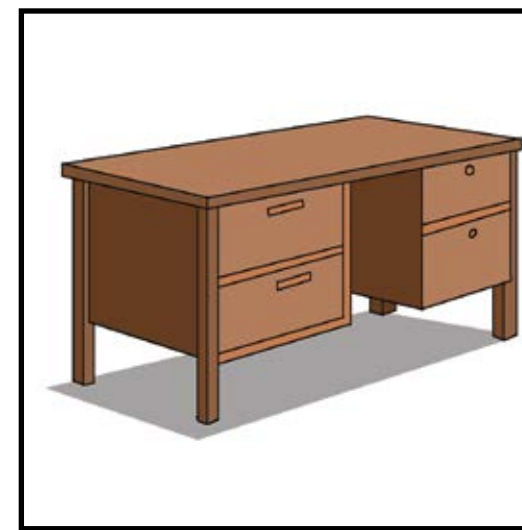
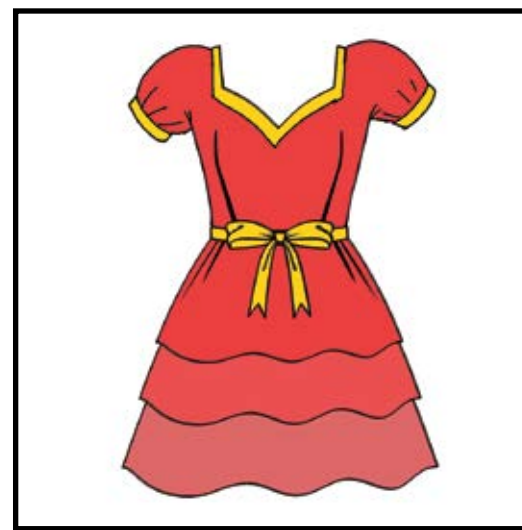
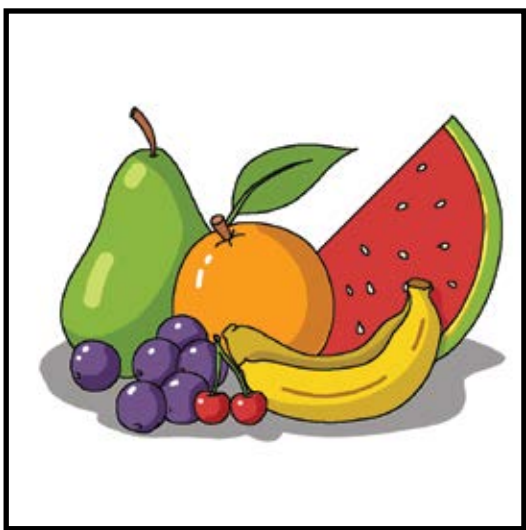

farmer

fence

fruit

dry

dress

desk



# Accelerated Adult Learning - Basic Literacy

## Lesson 47

### Making Houses

Name the letter and its sound.

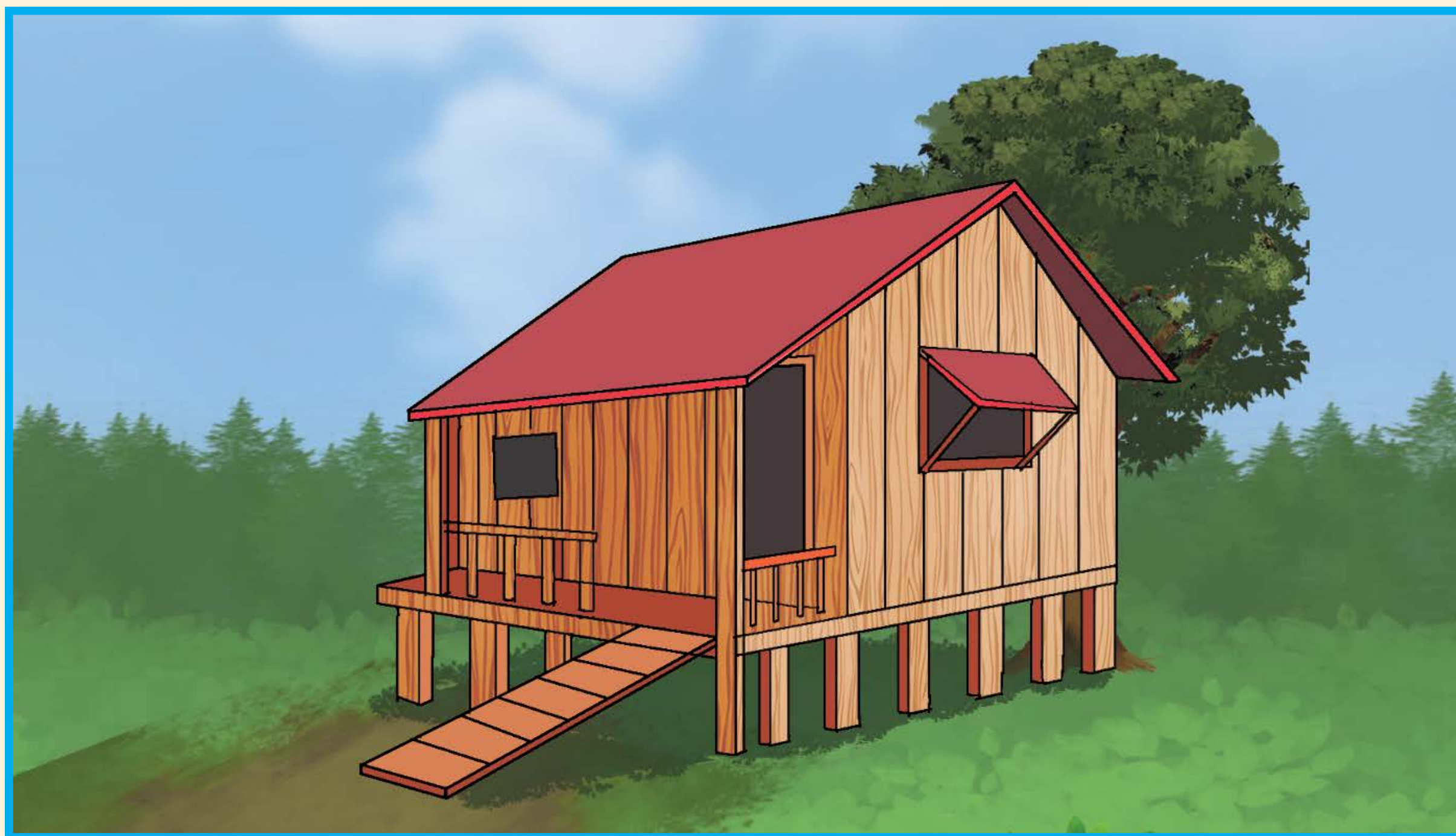

Father made a new **house**.

house

h

H

Name the pictures and match them with the words.

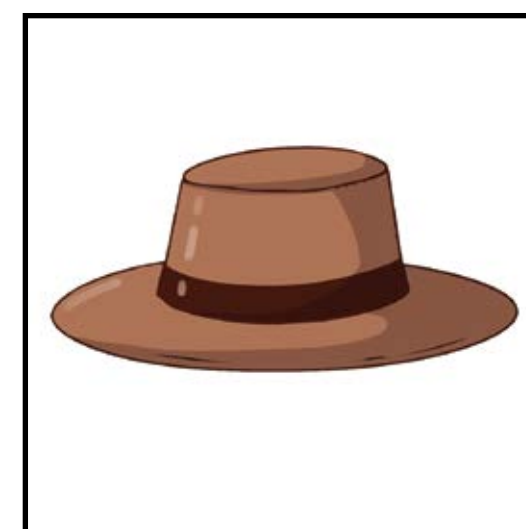
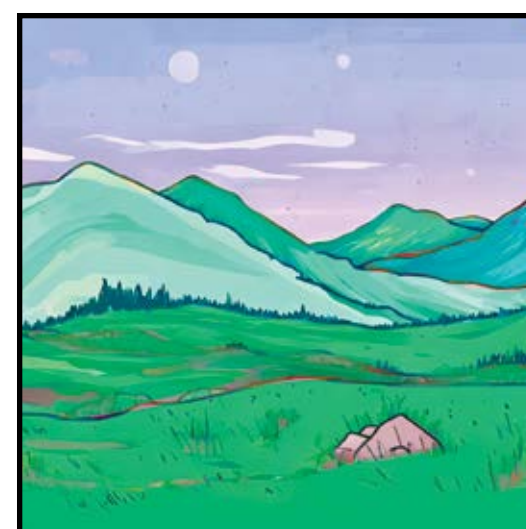
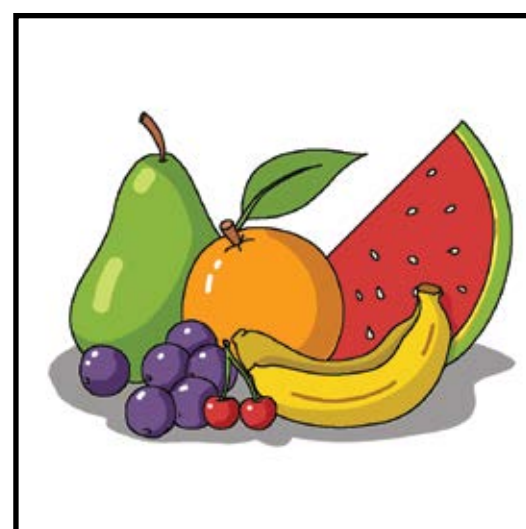
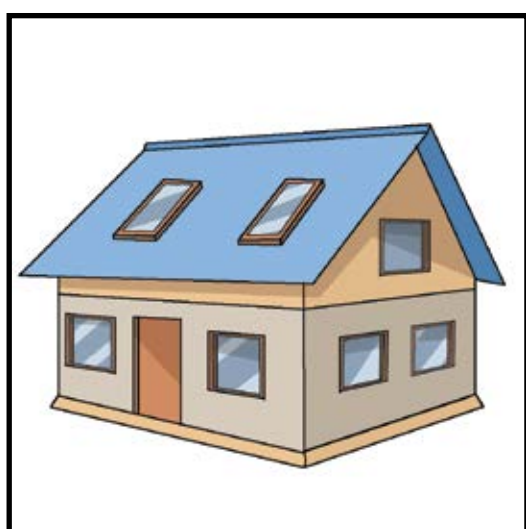

hat

house

hill

fence

farmer

fruit



# Accelerated Adult Learning - Basic Literacy

## Lesson 48

### Seasonal Businesses

Name the letter and its sound.



I sell **jackets** in the winter.

jackets  
j  
J

Name the pictures and match them with the words.

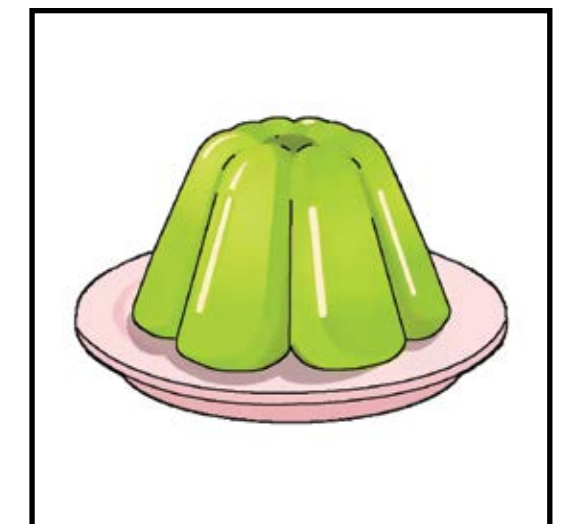
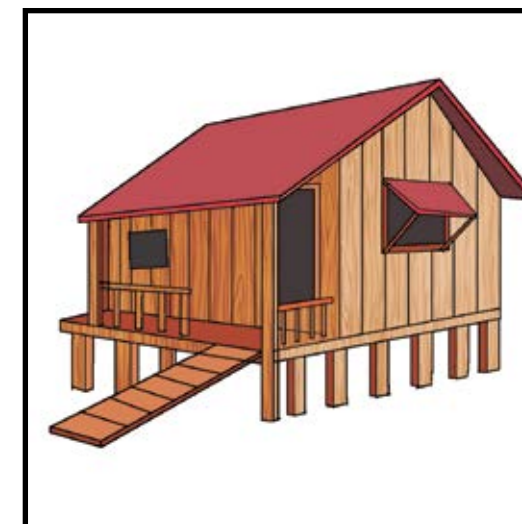
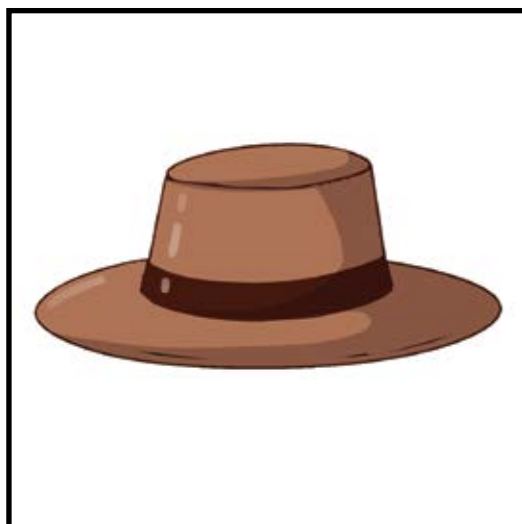

jelly

jacket

jeep

house

hat

hill



# Accelerated Adult Learning - Basic Literacy

## Lesson 49

### First Aid Kits

Name the letter and its sound.

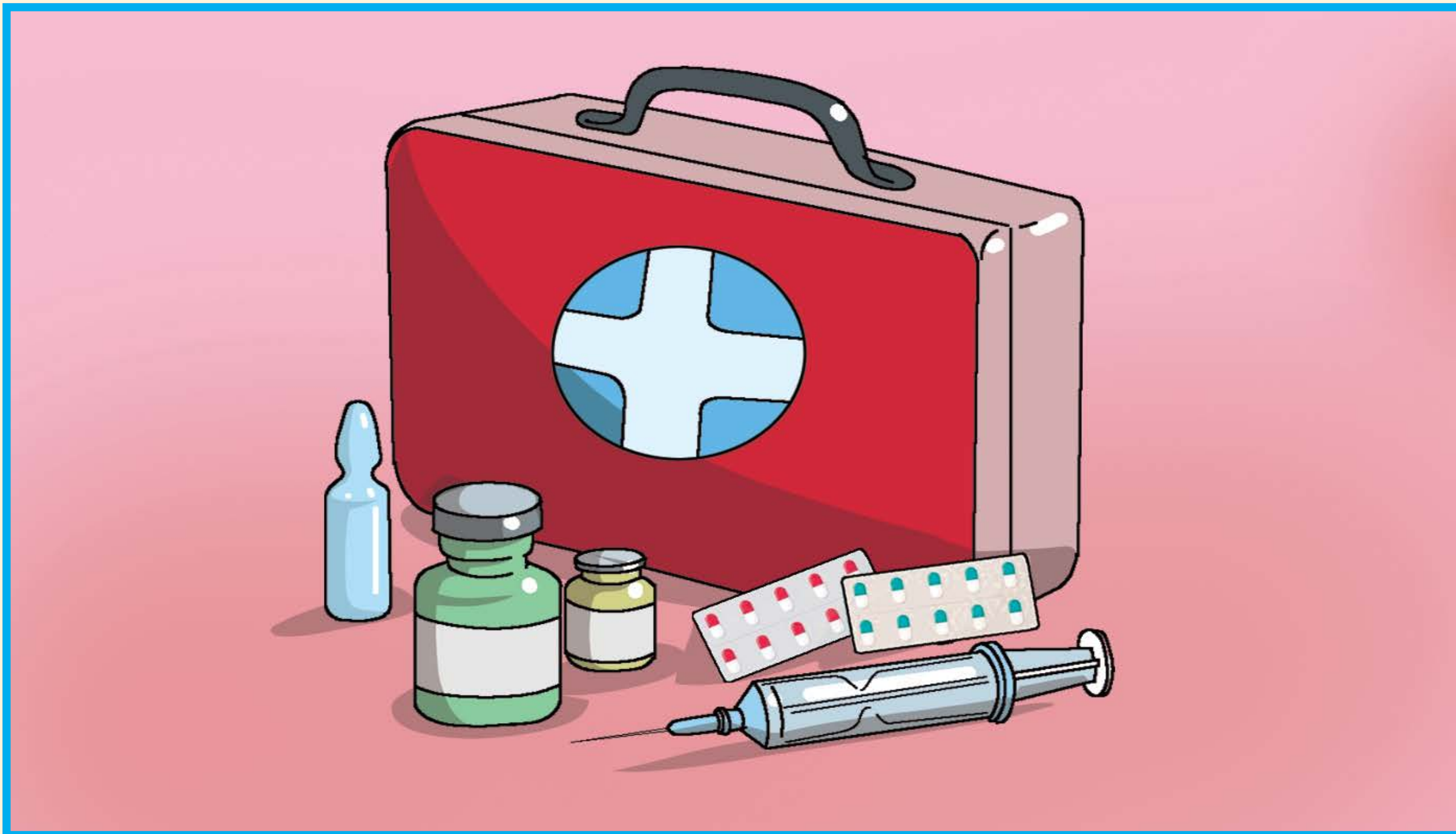

She has a first aid **kit**.

kit

k

K

Name the pictures and match them with the words.

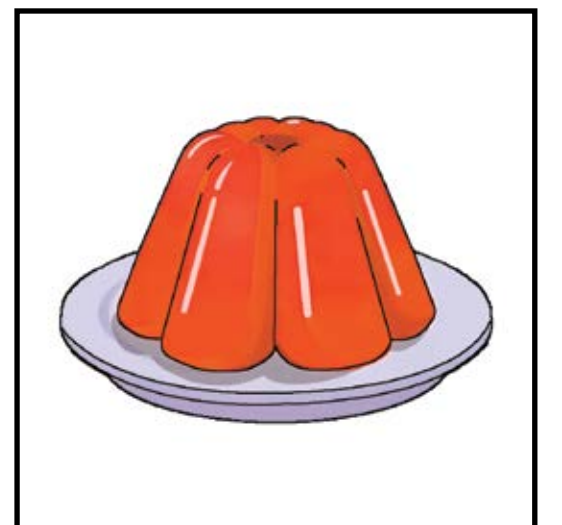
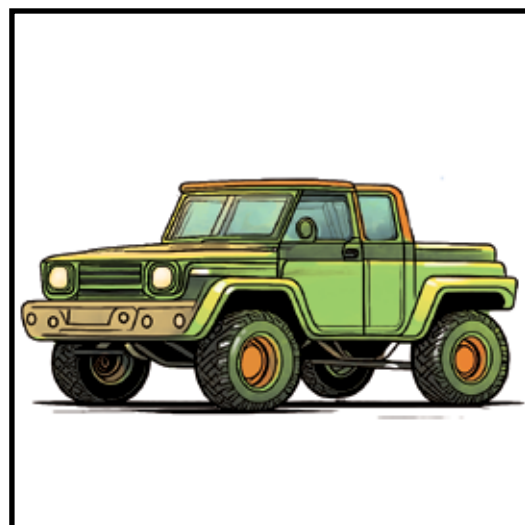
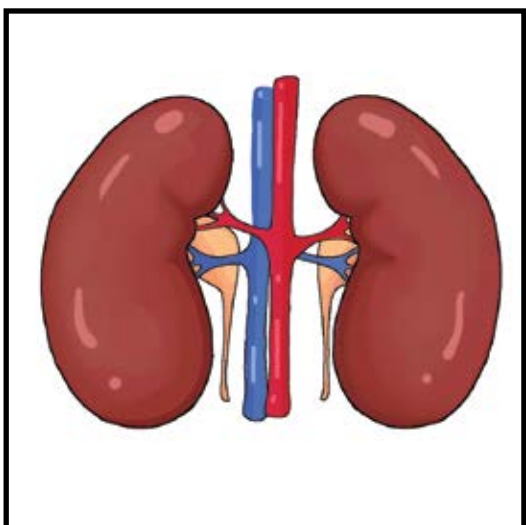

kit

kid

kidney

jelly

jacket

jeep



# Accelerated Adult Learning - Basic Literacy

## Lesson 50

### Review

Name the letter and its sound.



Brother cut tomatoes into **thick** slices.

thick  
th  
TH

Name the pictures and match them with the words.

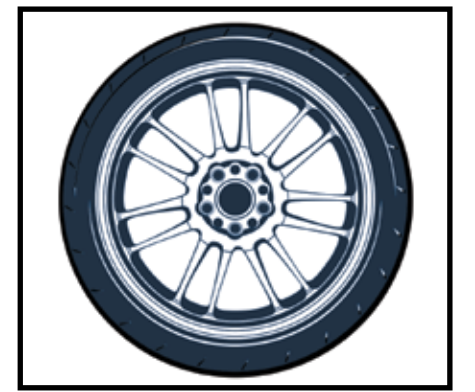
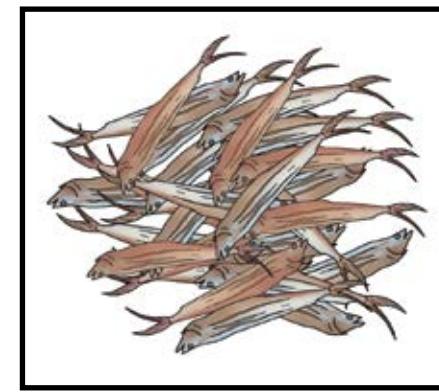
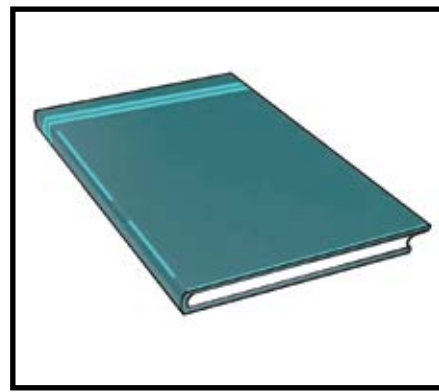
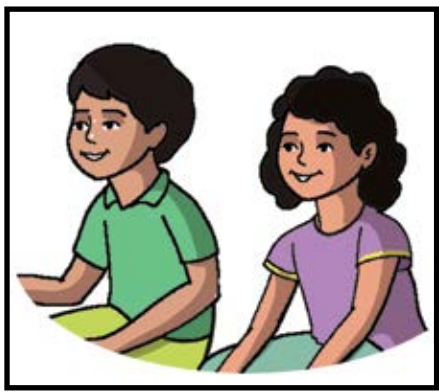

thin

wheel

gender

business

dry fish

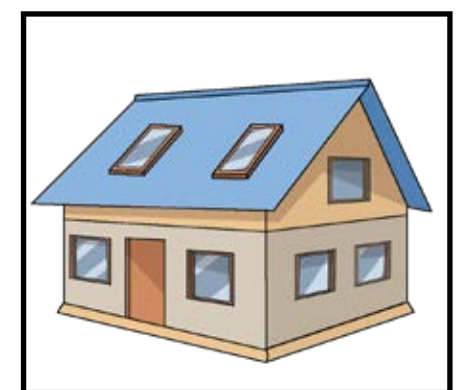
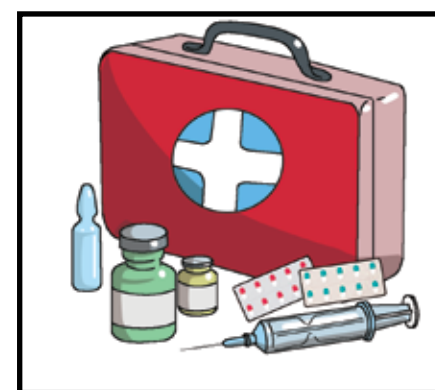
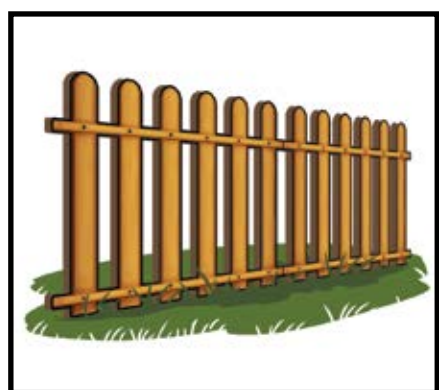

fence

house

jacket

kit



# Accelerated Adult Learning (Basic Literacy) **Lesson 51-60** Flipchart



**ISEC** 

Improving Skills and  
Economic Opportunities  
for Cox's Bazar



# Accelerated Adult Learning - Basic Literacy

## Lesson 51 Lamp Making

Name the letter and its sound.

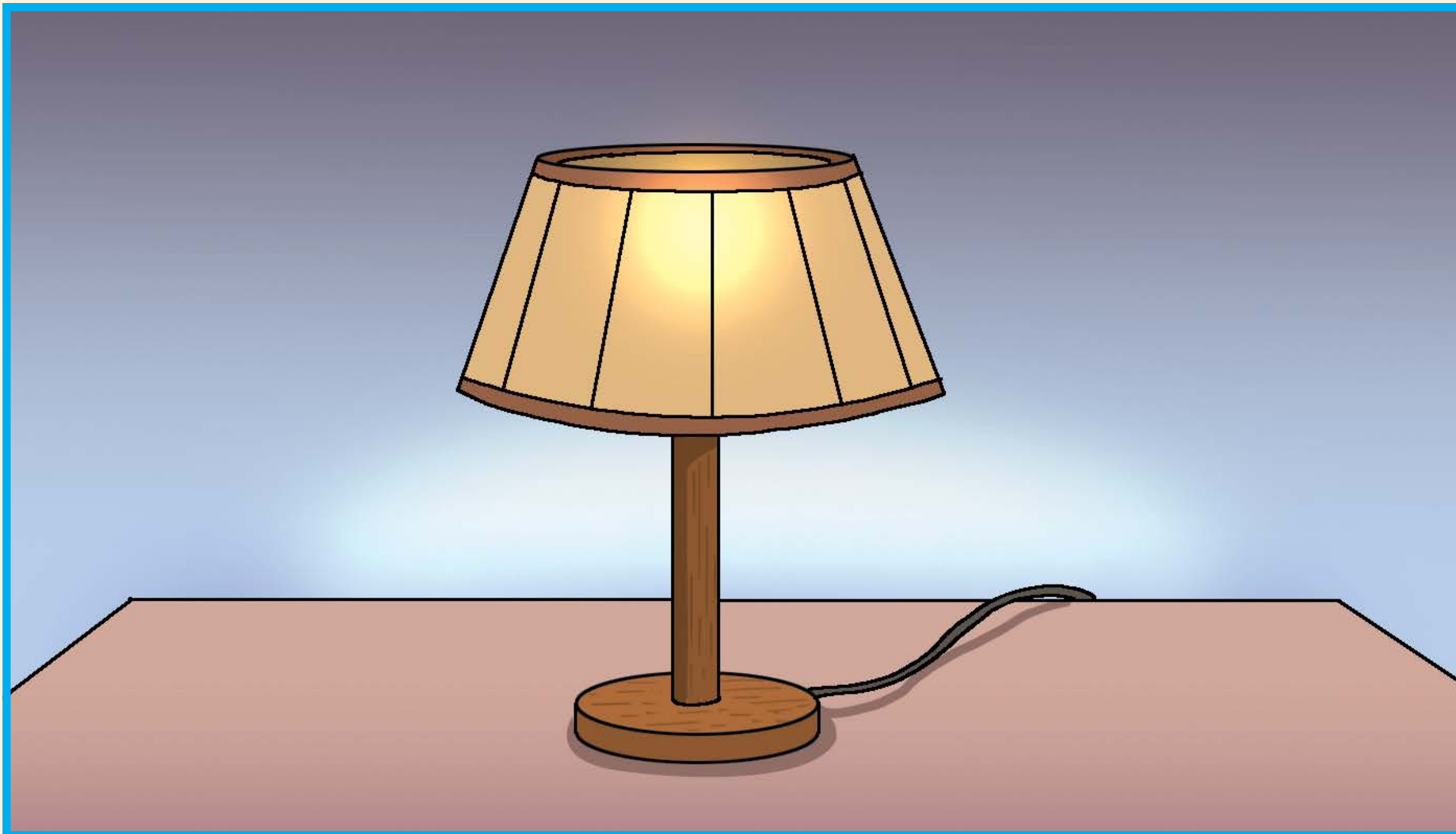

Sister made a **lamp**.

l  
amp  
l  
amp

Name the pictures and match them with the words.

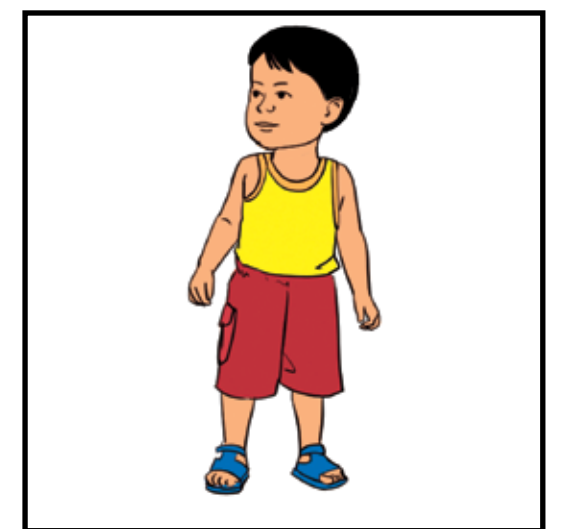
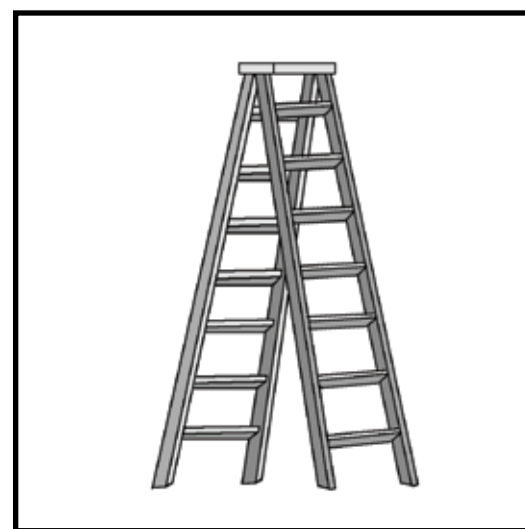
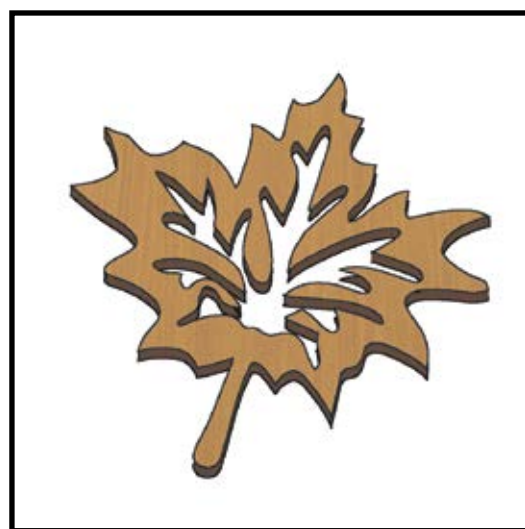
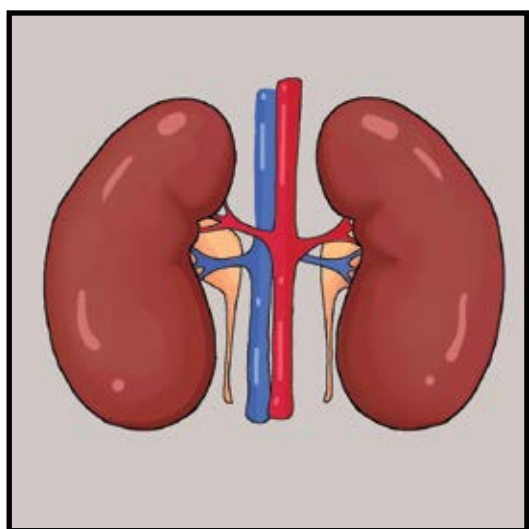

leaf

lamp

ladder

kit

kid

kidney



# Accelerated Adult Learning - Basic Literacy

## Lesson 52

### Pottery

Name the letter and its sound.



I like **mugs** made of clay.

mugs  
m  
M

Name the pictures and match them with the words.

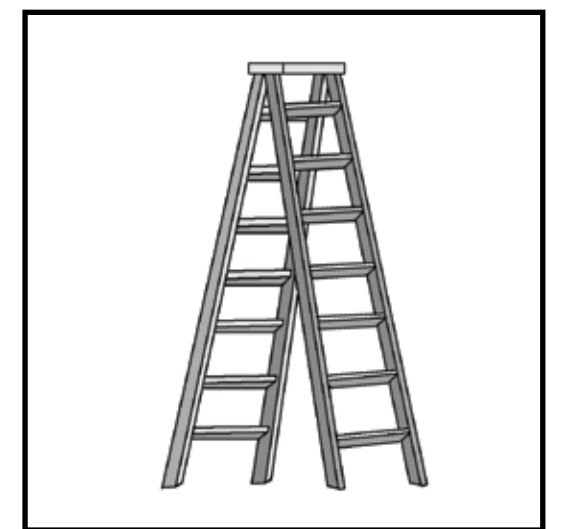
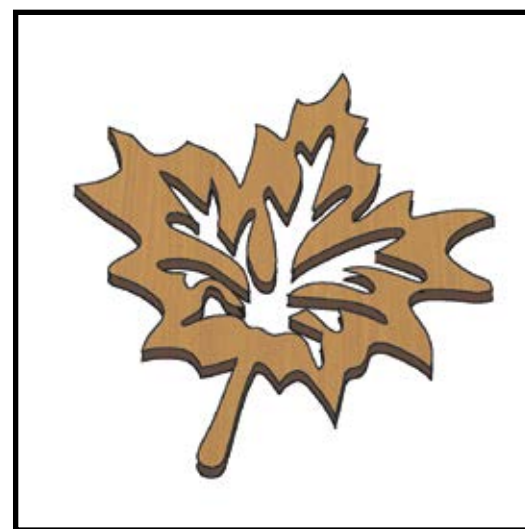

mask

market

mugs

lamp

ladder

leaf



# Accelerated Adult Learning - Basic Literacy

## Lesson 53 Bead Necklaces

Name the letter and its sound.

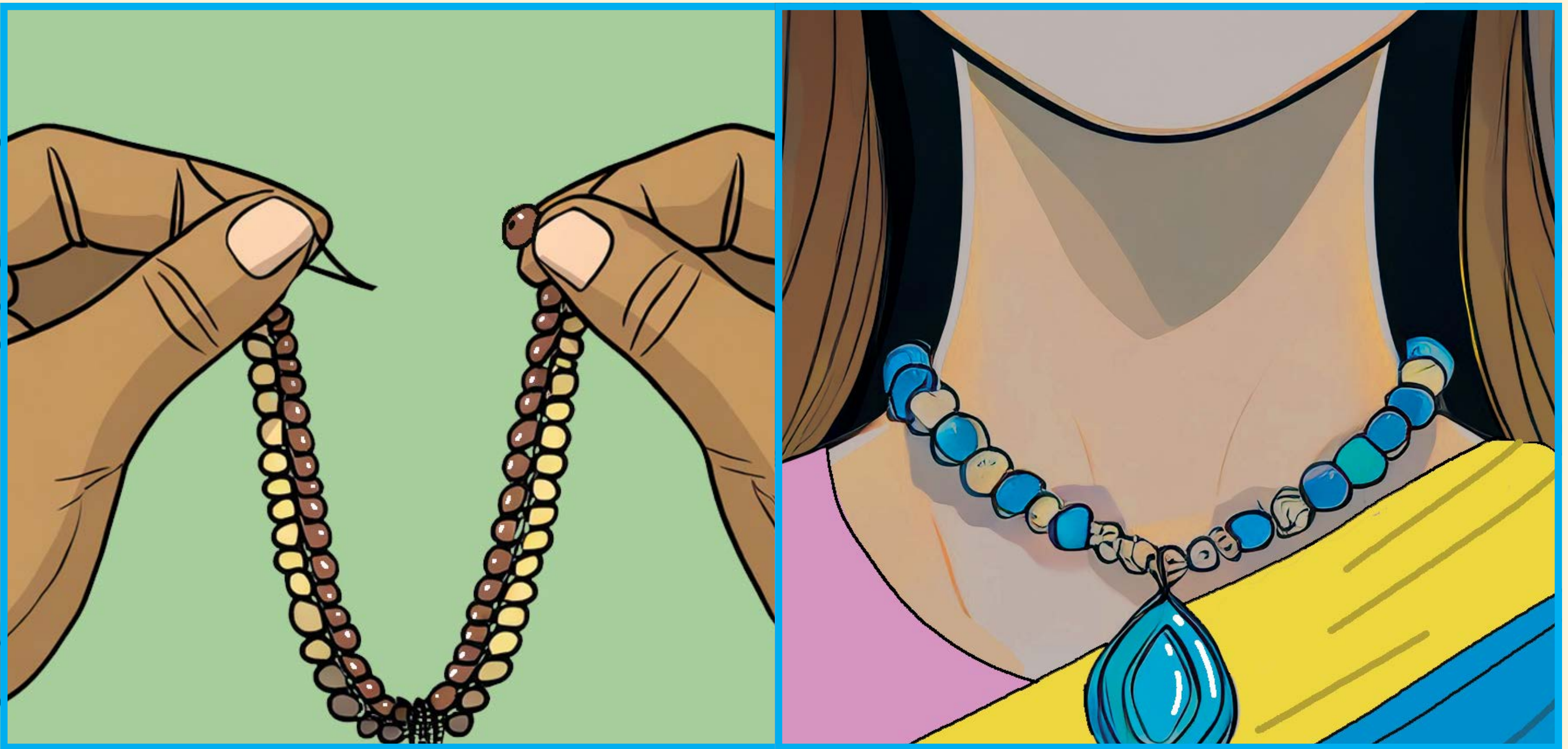

Asma made a bead **necklace**.

n  
necklace

n

N

Name the pictures and match them with the words.

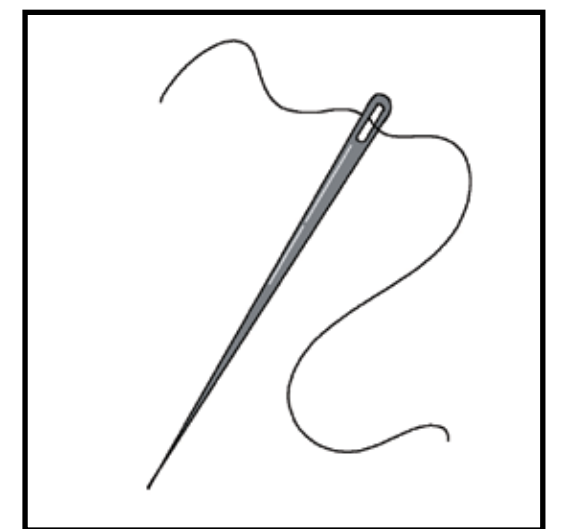
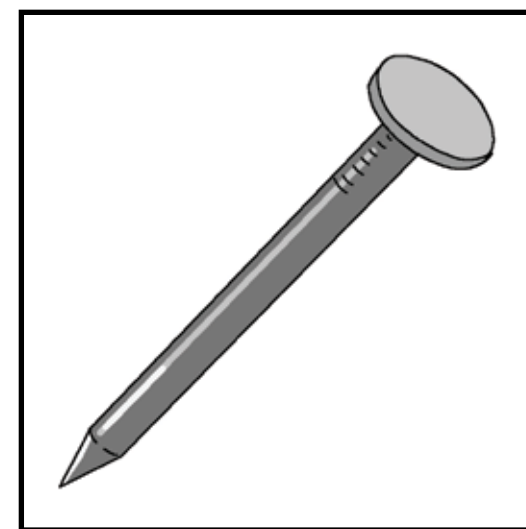
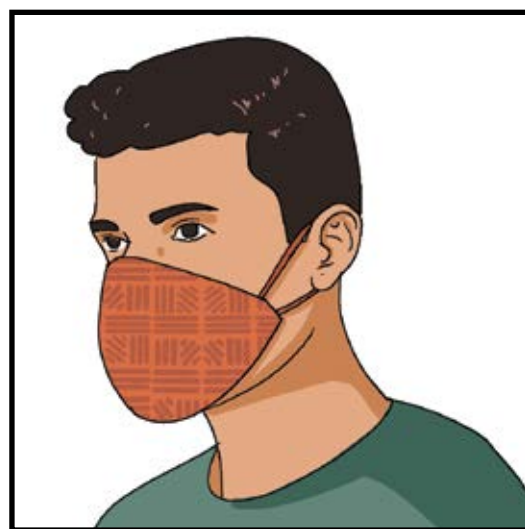
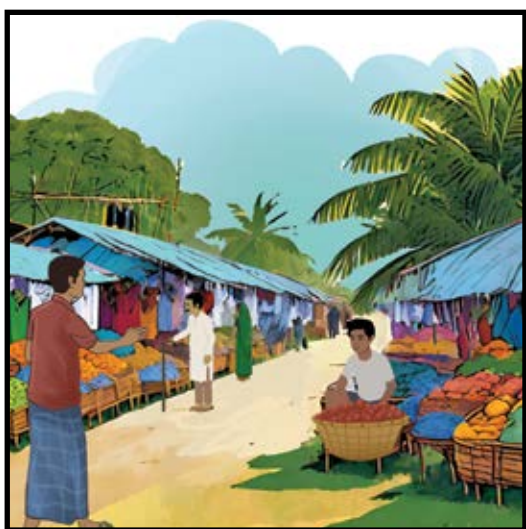

n  
needle

n  
necklace

n  
nail

m  
mask

m  
market

m  
mugs



# Accelerated Adult Learning - Basic Literacy

## Lesson 54 Handmade Quilts

Name the letter and its sound.



My mother made a **quilt**.

quilt  
qu  
QU

Name the pictures and match them with the words.

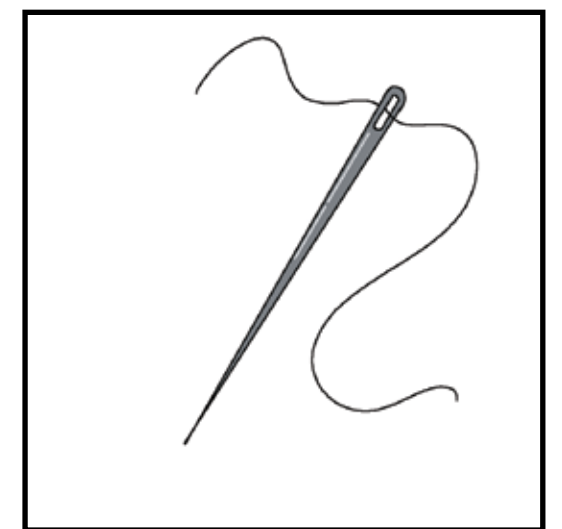
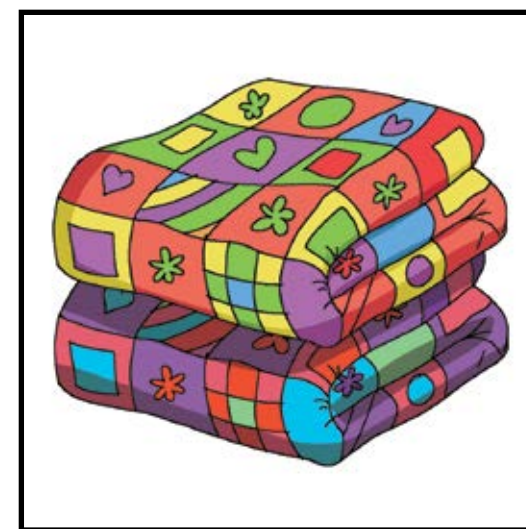
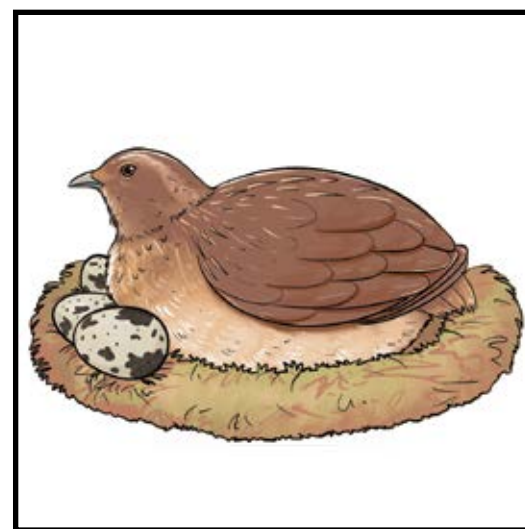

quail

queen

quilt

necklace

needle

nail



# Accelerated Adult Learning - Basic Literacy

## Lesson 55

### Drawing

Name the letter and its sound.

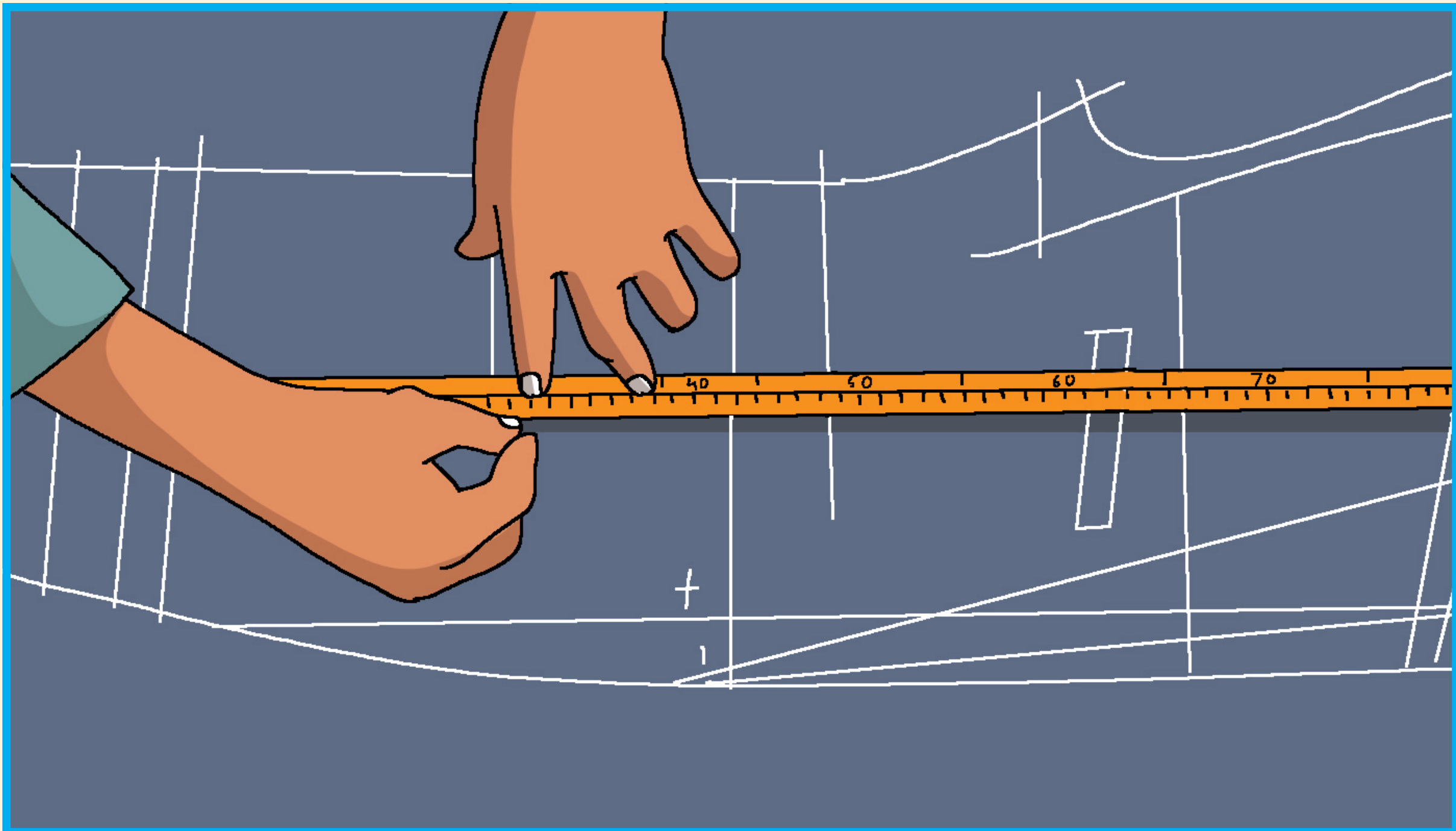

The tailor draws lines with a ruler.

ruler

r

R

Name the pictures and match them with the words.

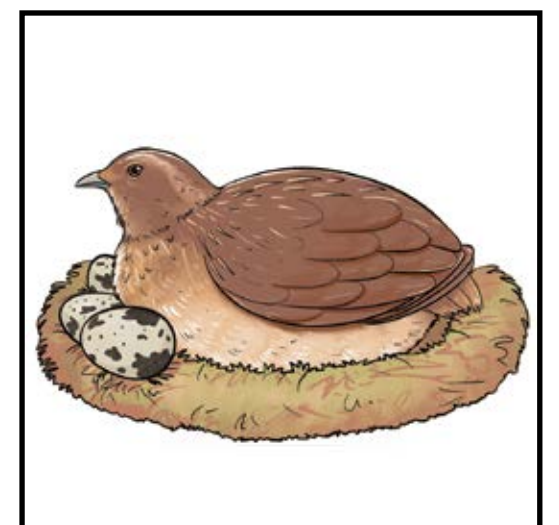
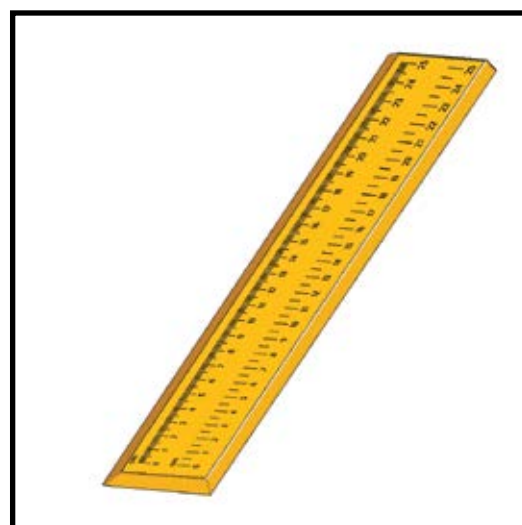

rain

ruler

roof

quail

queen

quilt



# Accelerated Adult Learning - Basic Literacy

## Lesson 56

### Vase Making

Name the letter and its sound.



I like to paint on a **v**ase.

vase

v

v

Name the pictures and match them with the words.

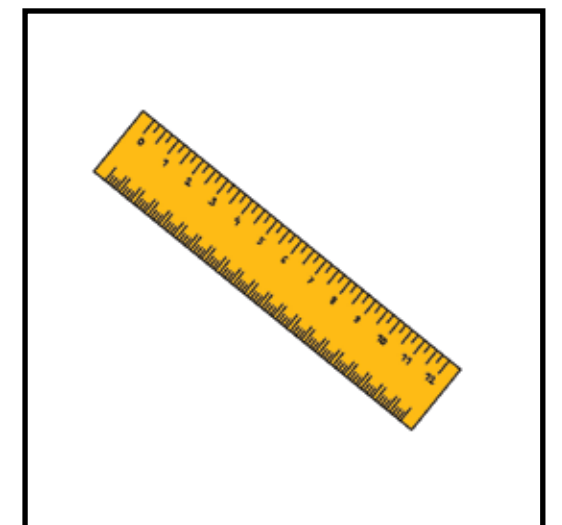
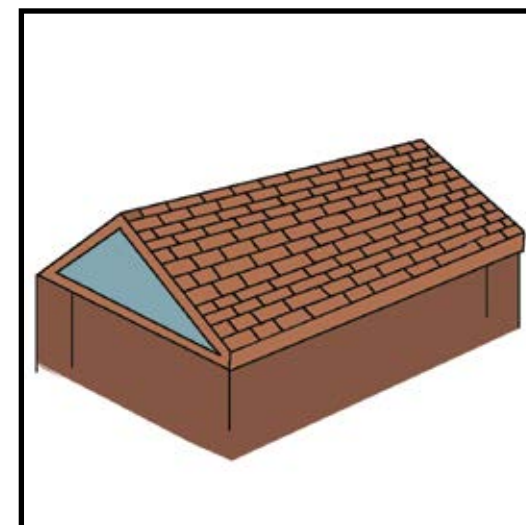

vase

vest

violin

ruler

rain

roof



# Accelerated Adult Learning - Basic Literacy

## Lesson 57

### Wooden Goods

Name the letter and its sound.



I made a wooden **box**.

box  
x  
x

Name the pictures and match them with the words.

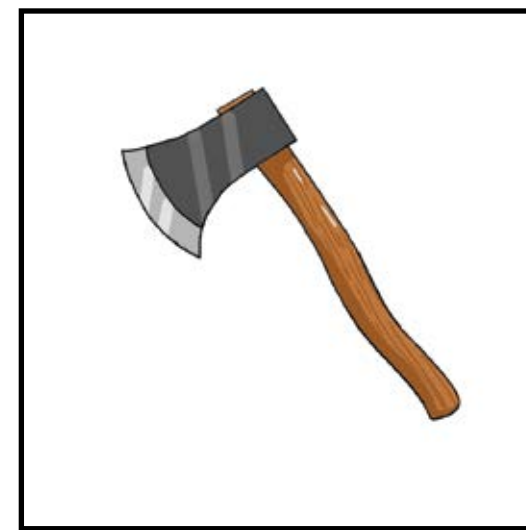

x-ray	box	axe	vase	vest	violin
-------	-----	-----	------	------	--------



# Accelerated Adult Learning - Basic Literacy

## Lesson 58

### Sewing Machines

Name the letter and its sound.

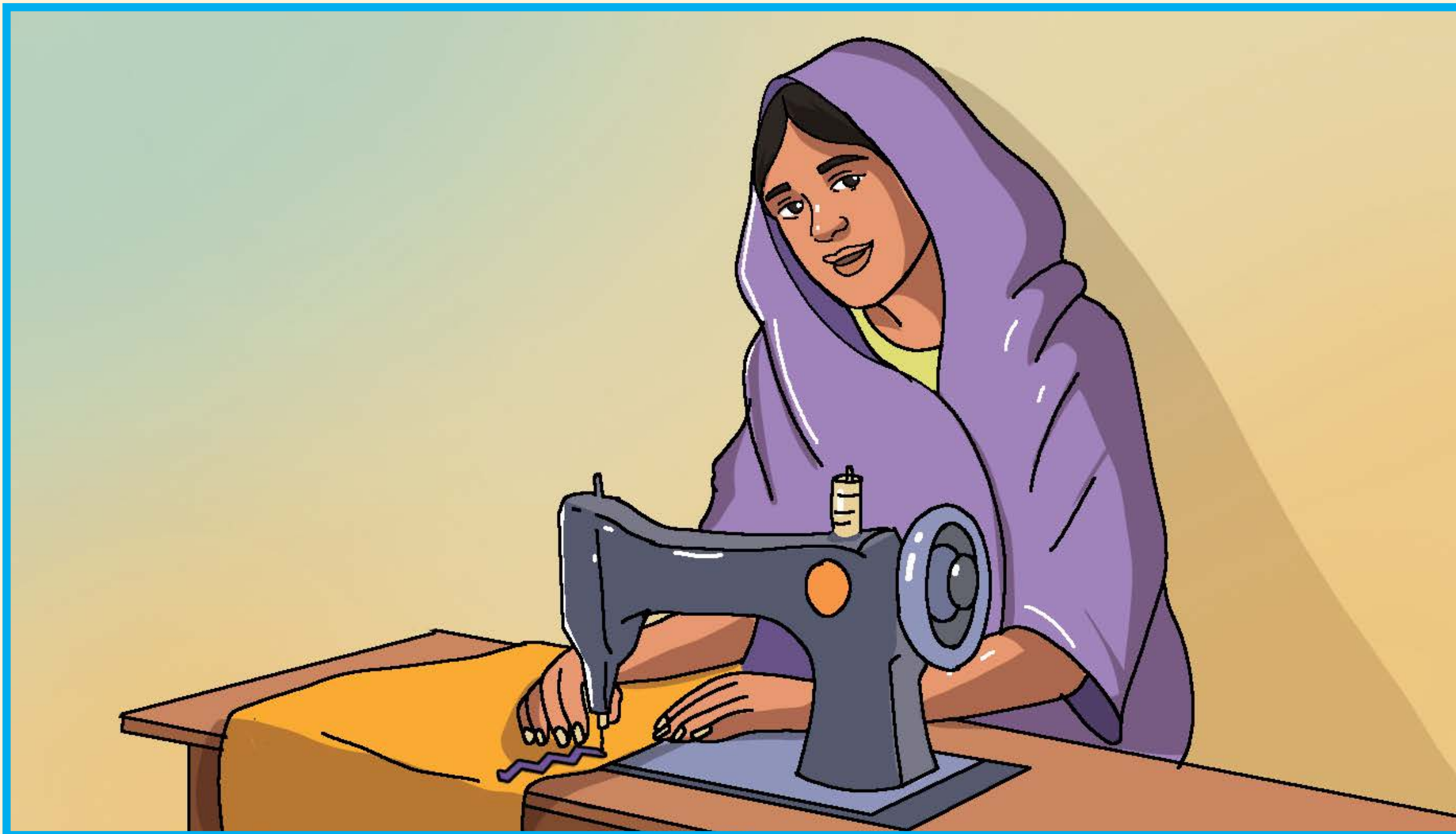

My mother did **zigzag** sewing.

zigzag

z

z

Name the pictures and match them with the words.

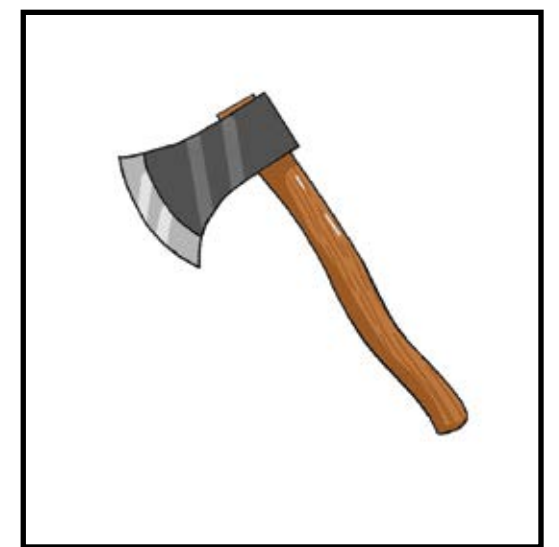
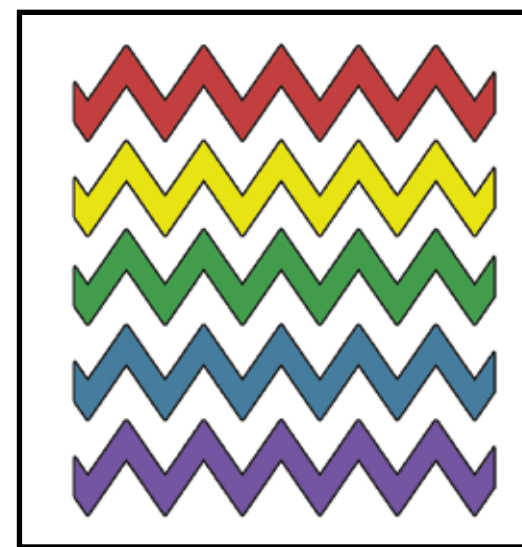
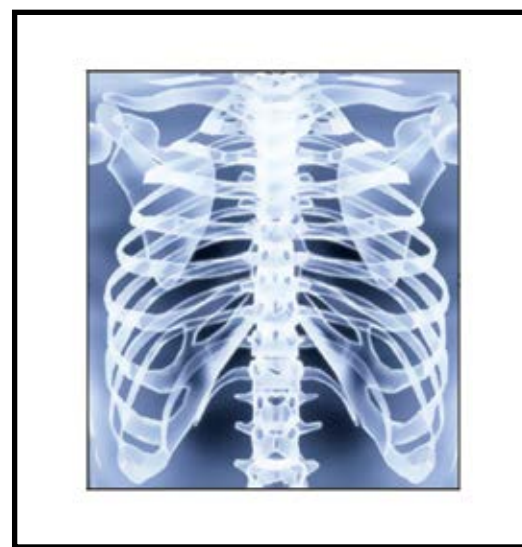
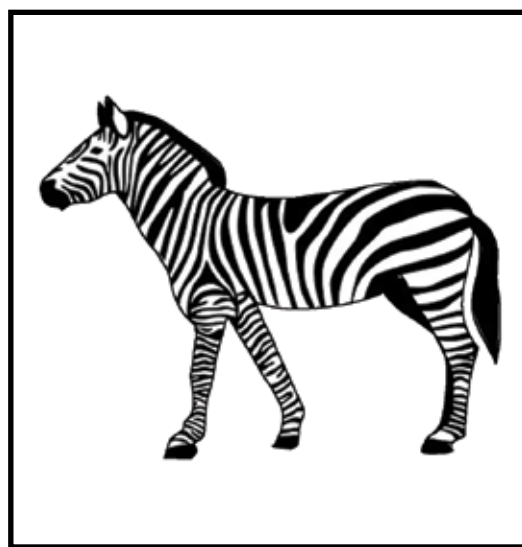
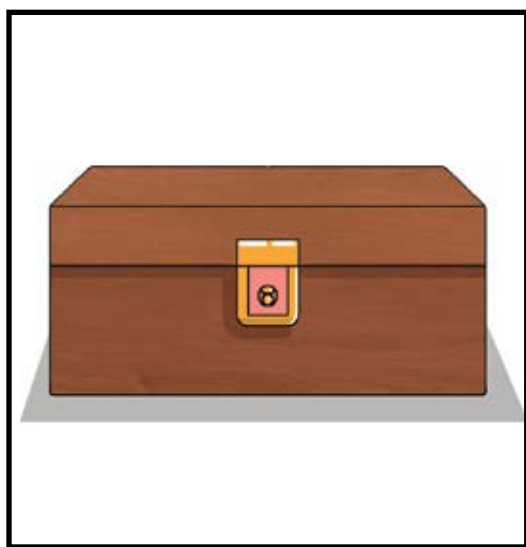
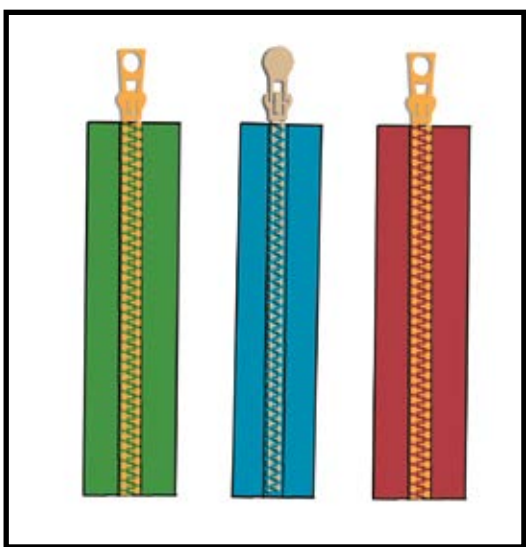

zebra

zigzag

zipper

axe

x-ray

box



# Accelerated Adult Learning - Basic Literacy

## Lesson 59

### Review

Name the letter and its sound.



My father painted on the **mug**.

mug  
m  
M

Name the pictures and match them with the words.

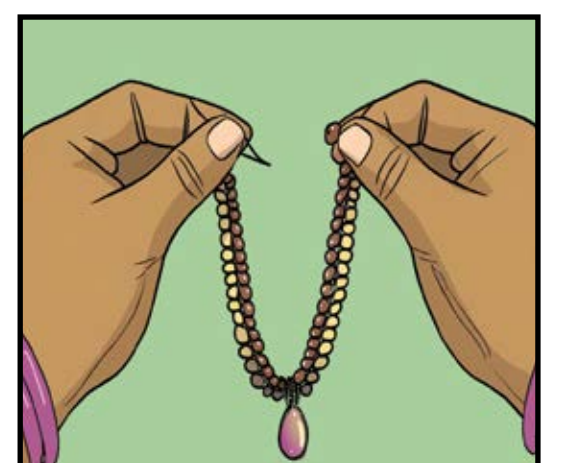
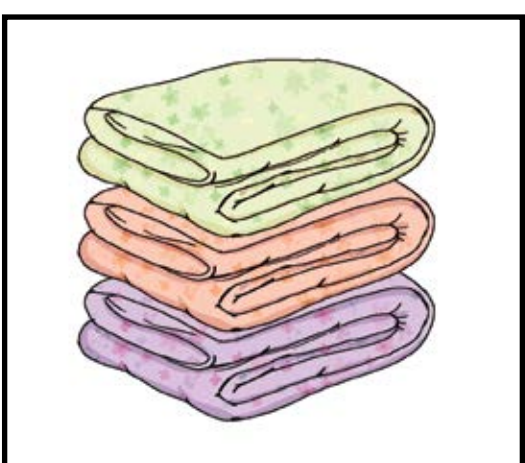

lamp

quilt

necklace

mug

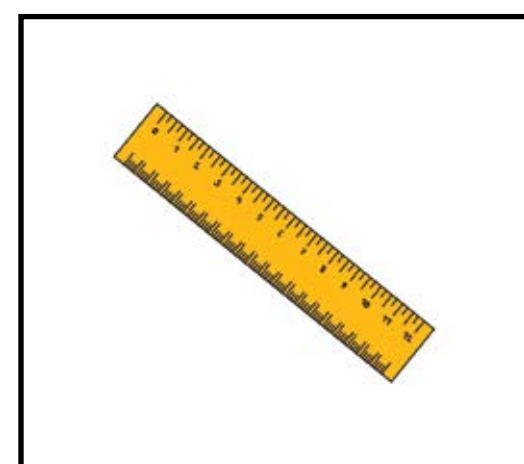

zigzag

vase

box

ruler



# Accelerated Adult Learning - Basic Literacy

## Lesson 60

### Review

Name the letter and its sound.

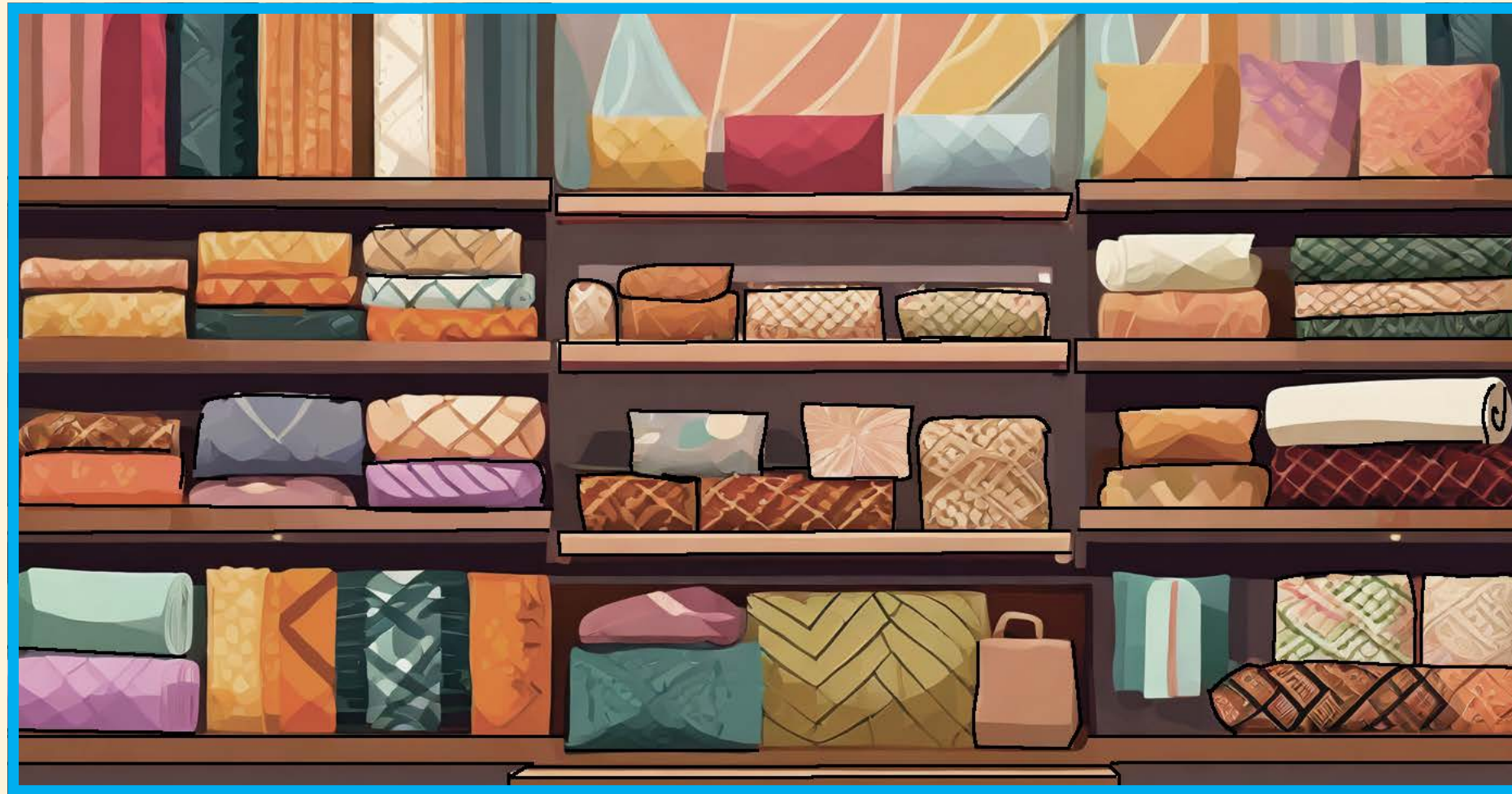

We have a **quilt** shop.

quilt  
qu  
QU

Name the pictures and match them with the words.

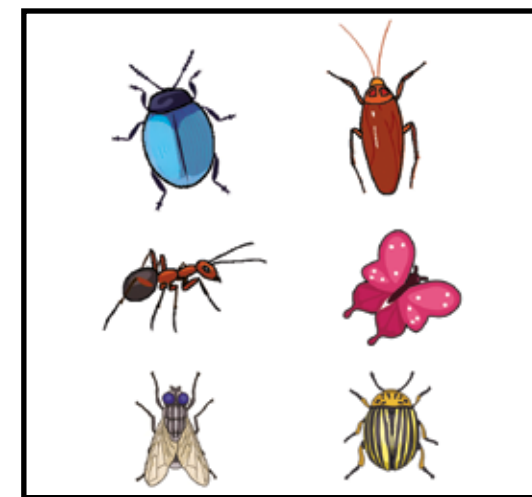
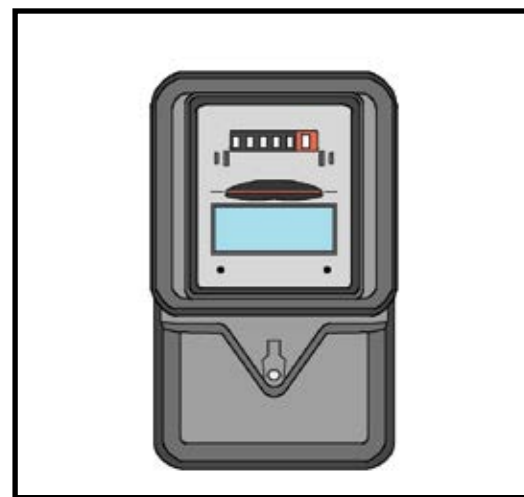
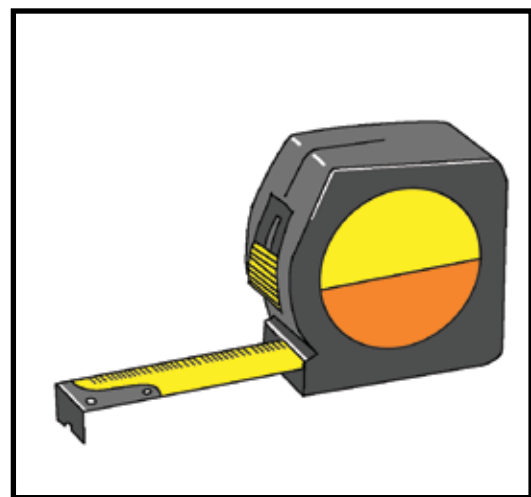
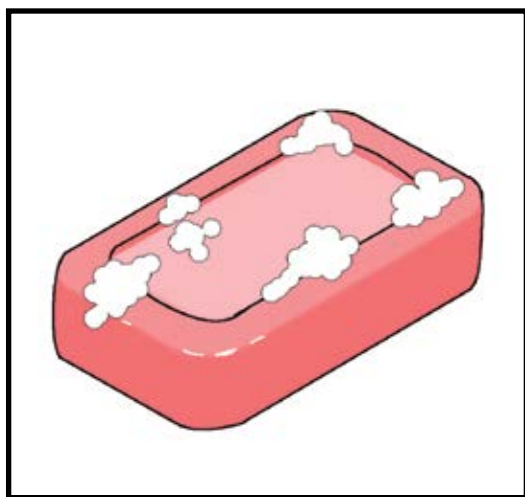

meter

insects

soap

tulips

tape

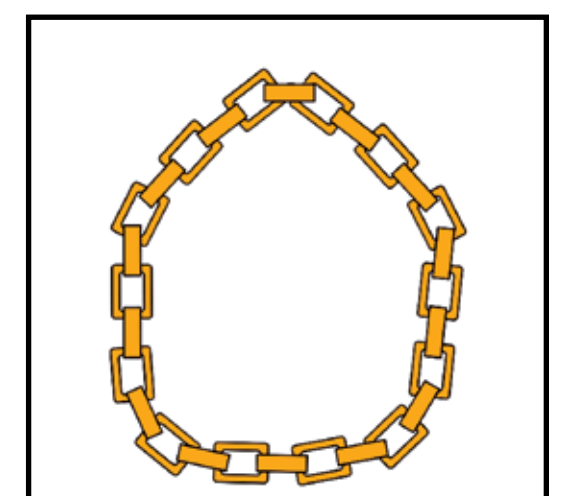
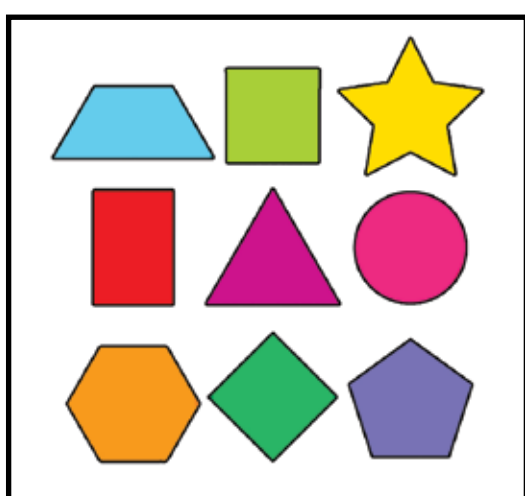

photo

chain

shape

dye



# Accelerated Adult Learning (Basic Literacy) **Lesson 61-70** Flipchart



**ISEC** 

Improving Skills and  
Economic Opportunities  
for Cox's Bazar



# Accelerated Adult Learning - Basic Literacy

## Lesson 61

### Using a Calendar

Read the sentence.



The shop is open seven **days** a **week**.

**days**

**week**

Name the pictures and match them with the words.

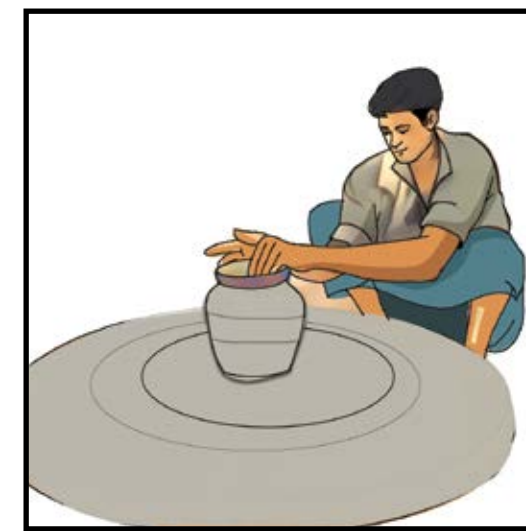
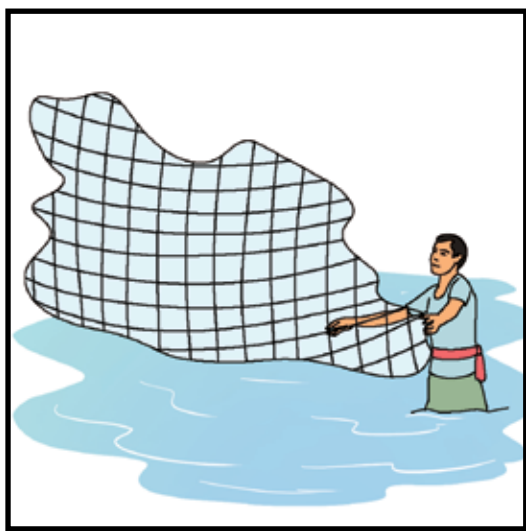
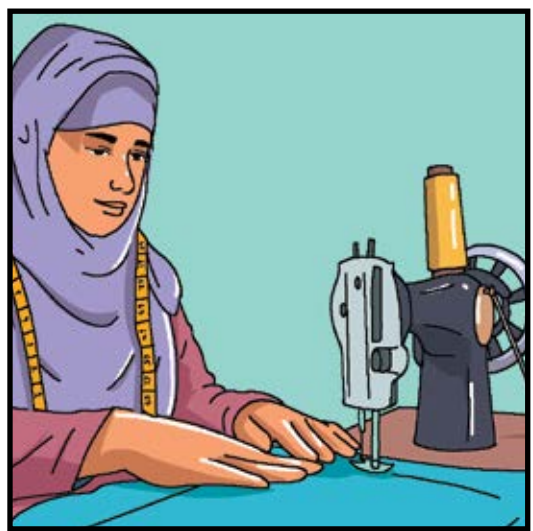

shopkeeper

potter

tailor

fisherman

carpenter

weaver

Read the days of the week.

Sunday

Monday

Tuesday

Tuesday

Thursday

Friday

Saturday



# Accelerated Adult Learning - Basic Literacy

## Lesson 62

### Working Days

Read the sentence.



I am working **today** and will have a rest **tomorrow**.

today

tomorrow

Name the pictures and match them with the words.

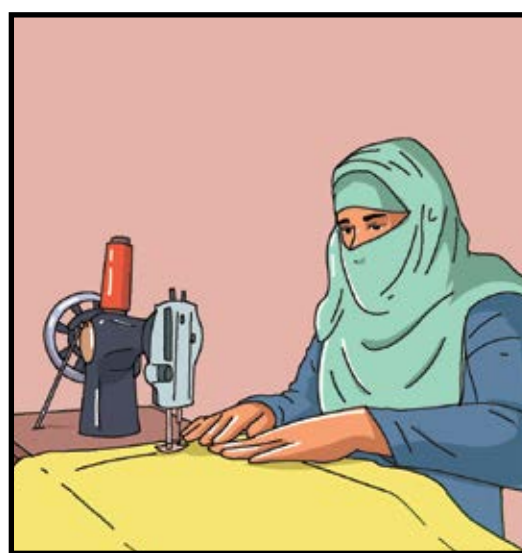

potter

tailor

carpenter

cook

welder

barber



# Accelerated Adult Learning - Basic Literacy

## Lesson 63

### Keeping Accounts

Read the sentence.



The shopkeeper made a profit **yesterday**.

yesterday

Name the pictures and match them with the words.

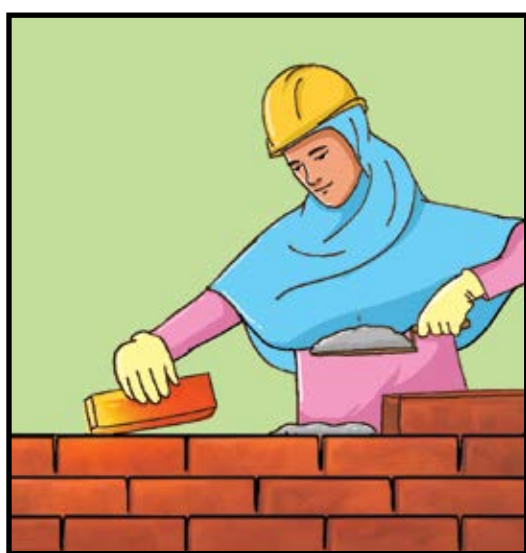

cook

welder

barber

painter

mason

driver



# Accelerated Adult Learning - Basic Literacy

## Lesson 64 Working Hours

Read the sentence.



Noman is **at home** today.

**at home**

Name the pictures and match them with the words.



painter

mason

driver

roofer

plumber

poultryman



# Accelerated Adult Learning - Basic Literacy

## Lesson 65 Vaccinations

Read the sentence.



I **am** in the clinic today.

am

Name the pictures and match them with the words.

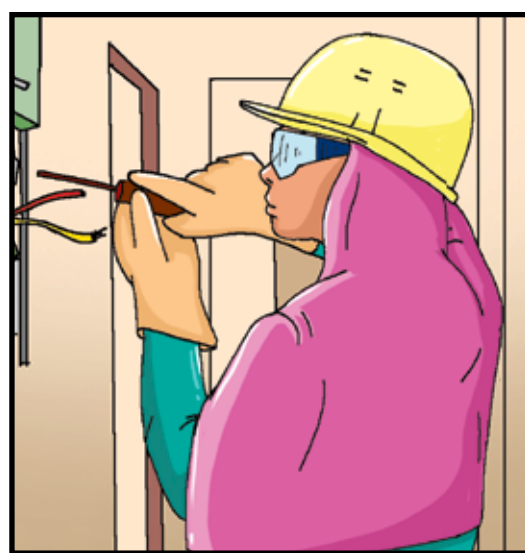

roofer

plumber

poultryman

farmer

gardener

electrician



# Accelerated Adult Learning - Basic Literacy

## Lesson 66

### Tailor

Read the sentence.

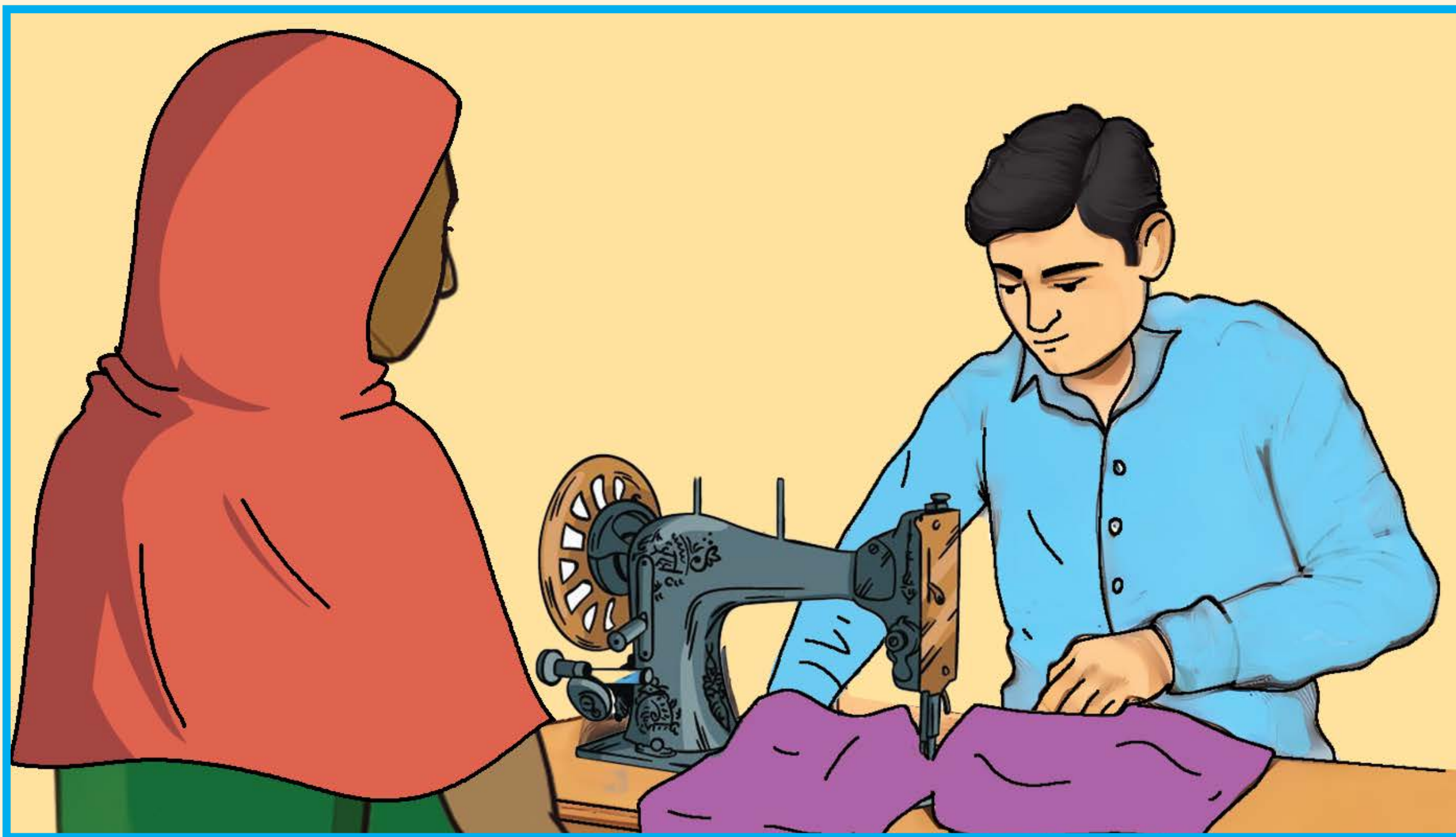

Asma went to the **tailor** **yesterday**.

tailor

yesterday

Name the pictures and match them with the words.

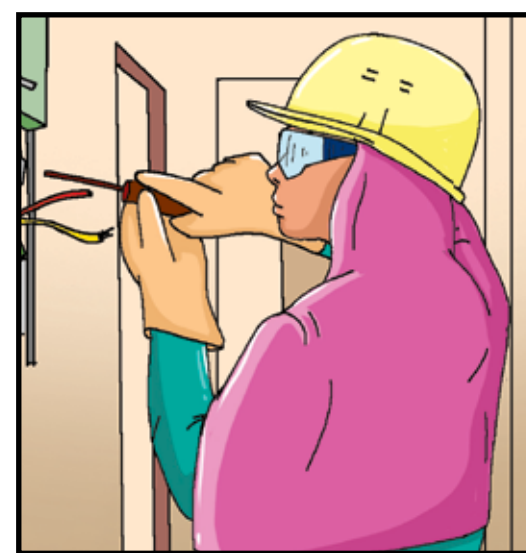
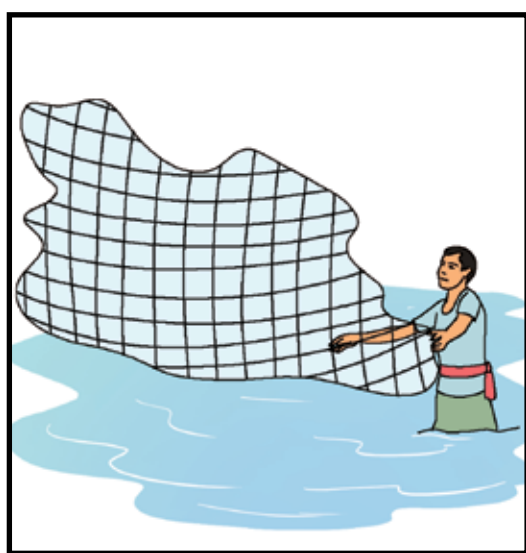

farmer

gardener

electrician

fisherman

jeweller

craftsperson



# Accelerated Adult Learning - Basic Literacy

## Lesson 67 Drying Fruit

Read the sentence.

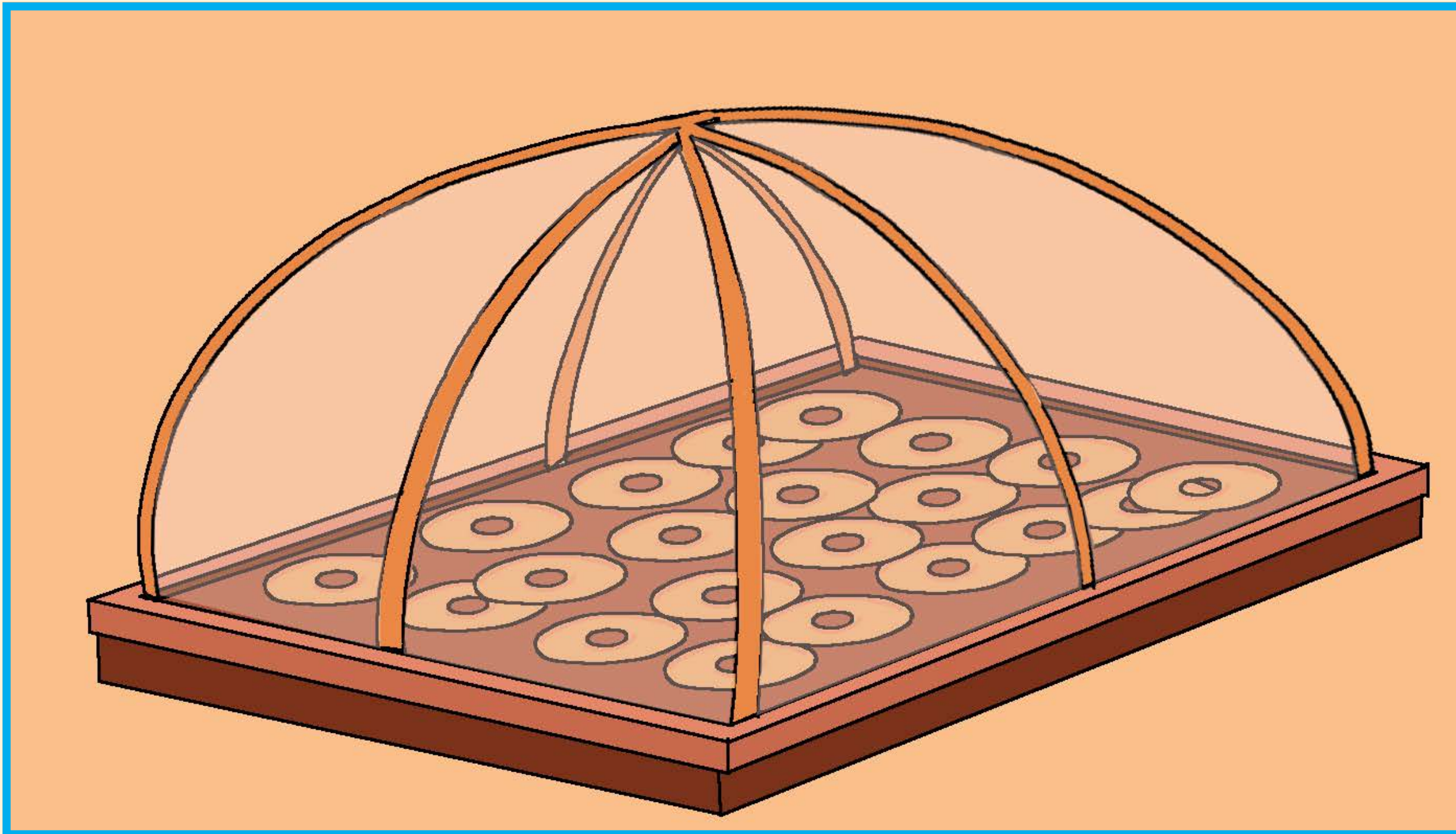

They **will dry** the fruit **tomorrow**.

will dry

tomorrow

Name the pictures and match them with the words.

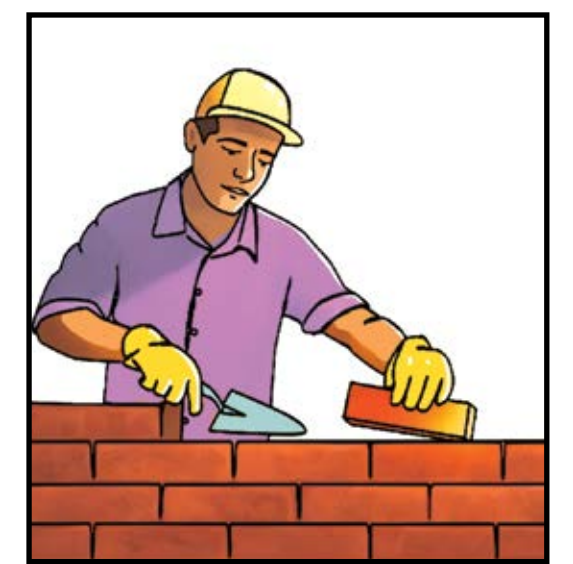
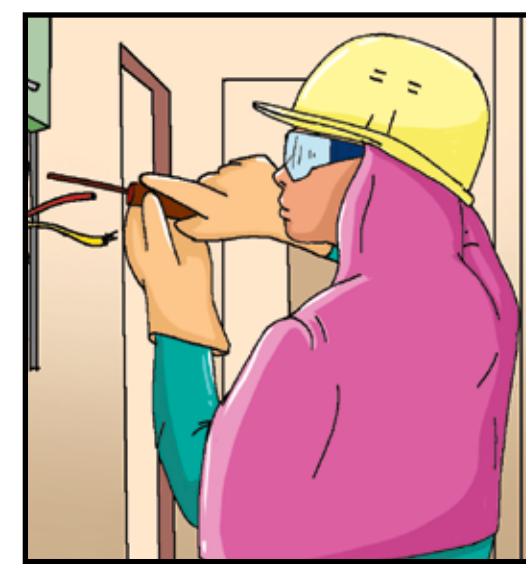
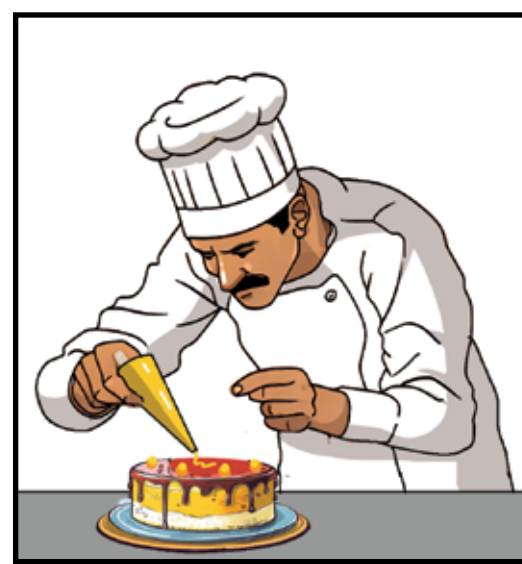

electrician

craftsperson

jeweller

baker

mason

barber



# Accelerated Adult Learning - Basic Literacy

## Lesson 68

### Storing Dry Food

Read the sentence.



We **sell** dry food in the **market**.

sell

market

Name the pictures and match them with the words.

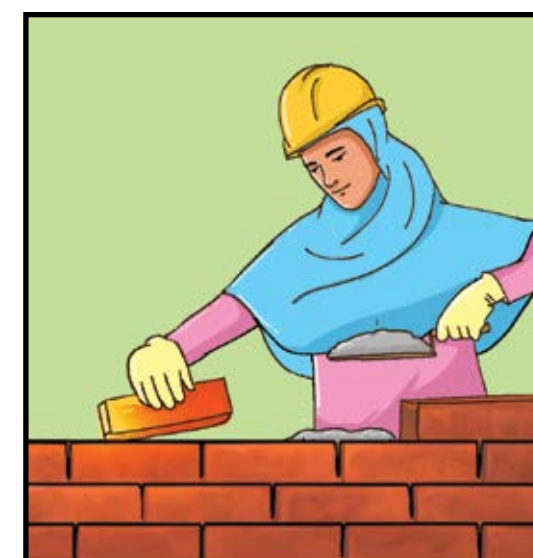

baker

mason

barber

concreter

food  
processor

mechanic



# Accelerated Adult Learning - Basic Literacy

## Lesson 69 Jeweller

Read the sentence.



Hazera went to a jeweller yesterday.

jeweller

yesterday

Name the pictures and match them with the words.

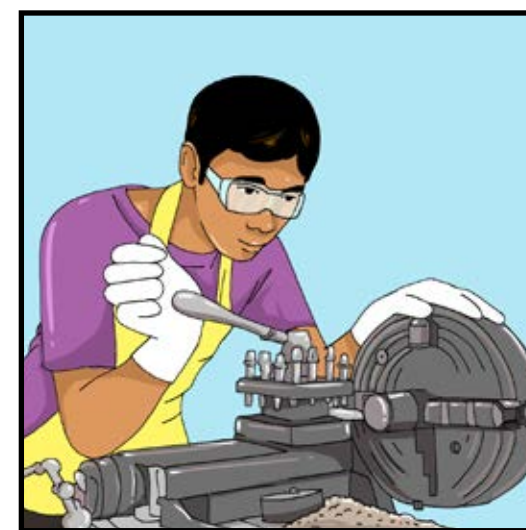

mechanic

food  
processor

concreter

tea  
seller

carpenter

health  
worker



# Accelerated Adult Learning - Basic Literacy

## Lesson 70

### Review

Read the sentence.

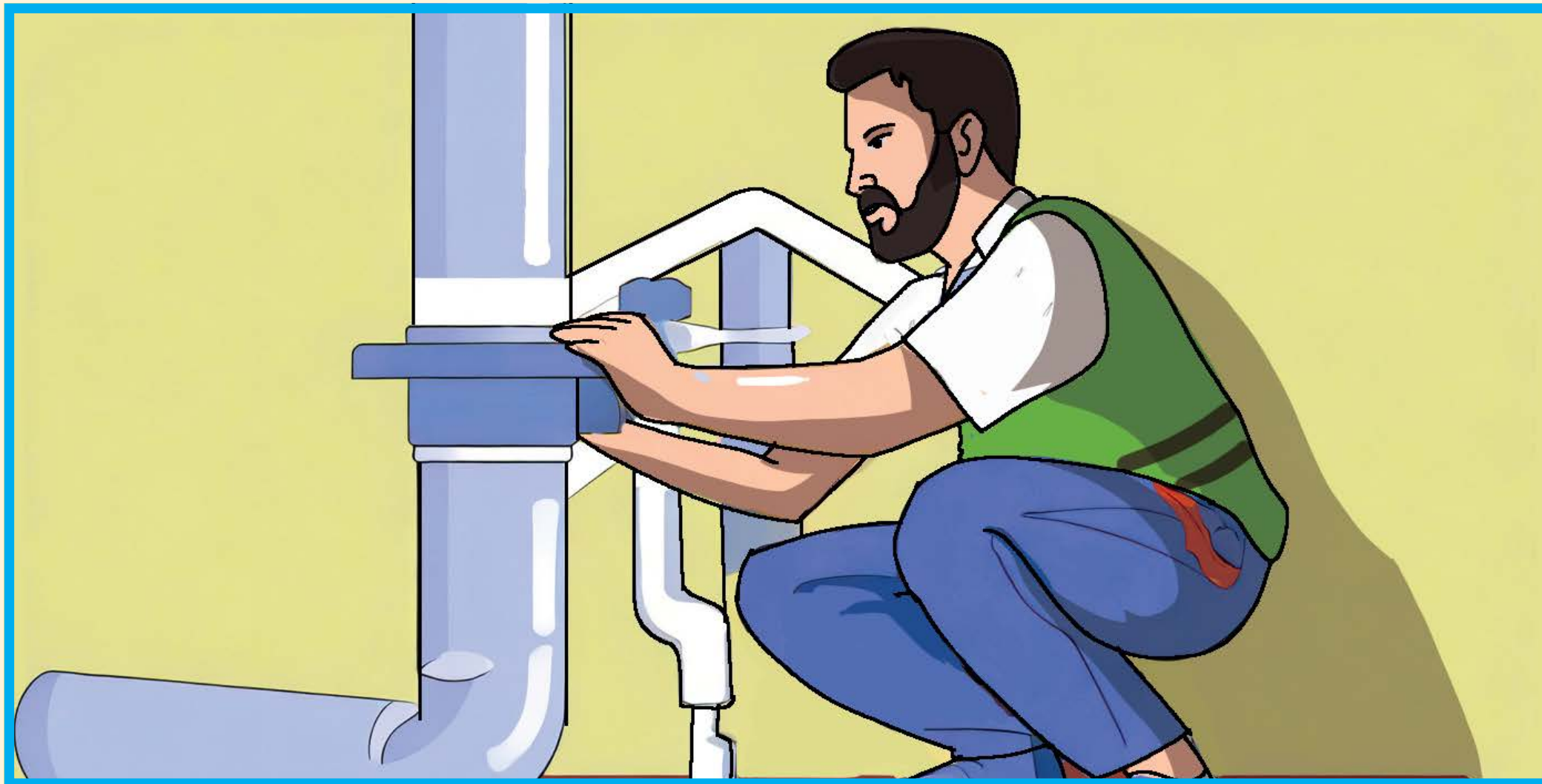

The **plumber fit** the pipes yesterday.

plumber

fit

Name the letter and its sound.

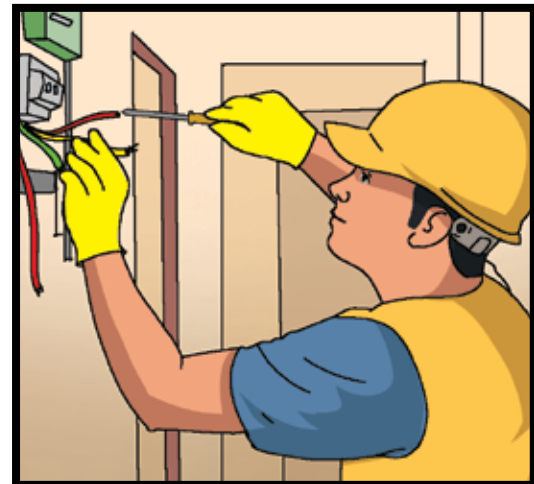

carpenter

barber

electrician

craftperson

plumber



tailor

health  
worker

machanic

food  
processor



# Accelerated Adult Learning (Basic Literacy) **Lesson 71-80** Flipchart



**ISEC** 

Improving Skills and  
Economic Opportunities  
for Cox's Bazar



# Accelerated Adult Learning - Basic Literacy

## Lesson 71

### Barber

Read the sentence.



All twelve months I make jute goods.

tweleve

months

Name the pictures and match them with the words.

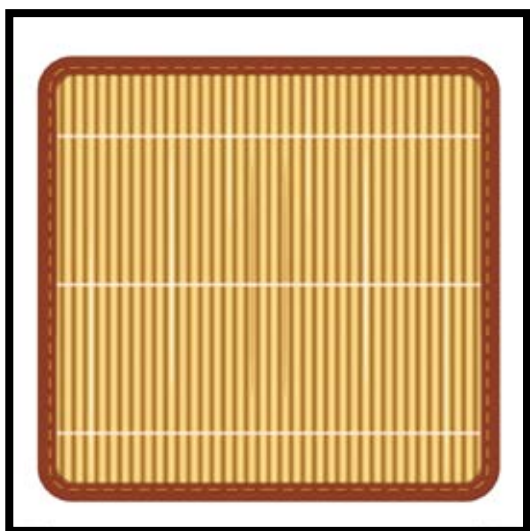

rak

bag

table

basket

mat

cage



# Accelerated Adult Learning - Basic Literacy

## Lesson 72

### Barber

Read the sentence.



Rahim went to the **barber last** month.

barber

last

Name the pictures and match them with the words.

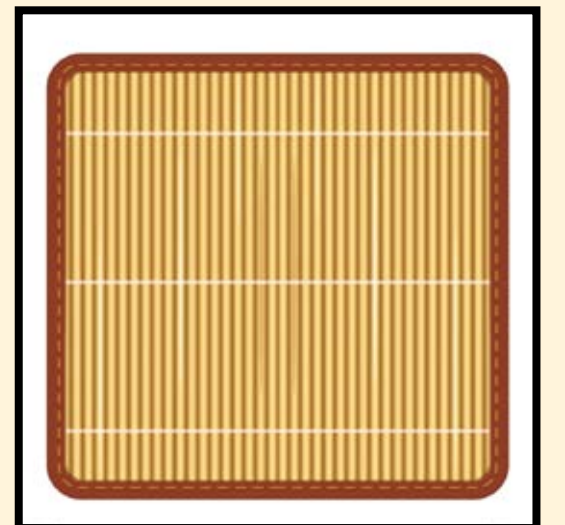

bag

basket

mat

scissors

mirror

apron



# Accelerated Adult Learning - Basic Literacy

## Lesson 73 Furniture Shop

Read the sentence.



Setara will **start** a **shop** for wooden goods.

start

shop

Name the pictures and match them with the words.



scissors

mirror

apron

chair

table

almirah



# Accelerated Adult Learning - Basic Literacy

## Lesson 74 House Wiring

Read the sentence.



An **electrician** **wired** my new **house**.

**electrician**

**wired**

**house**

Name the pictures and match them with the words.

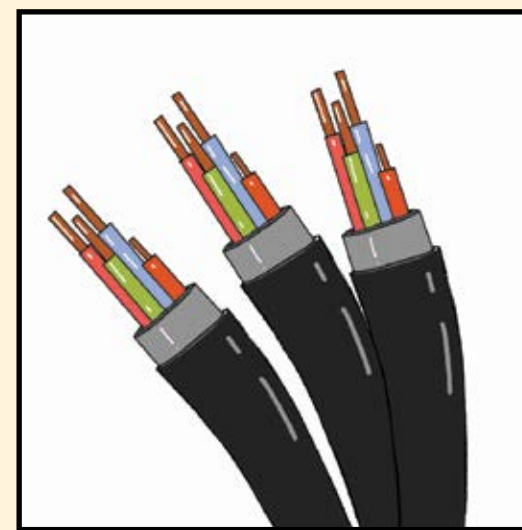
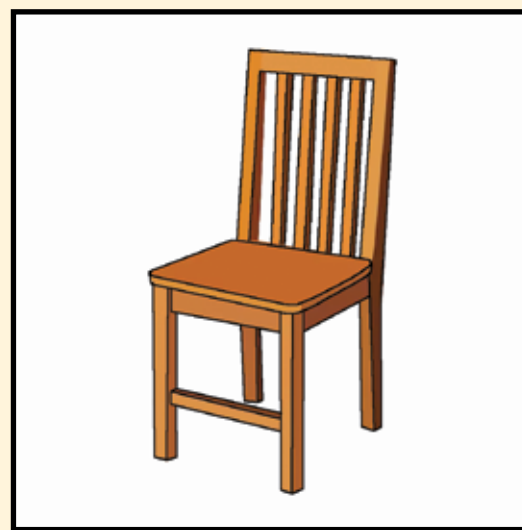
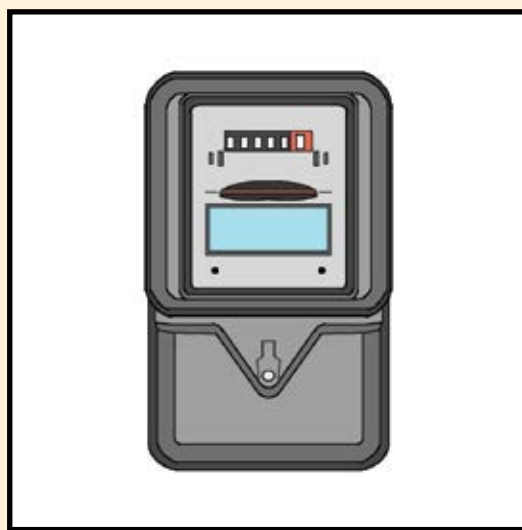
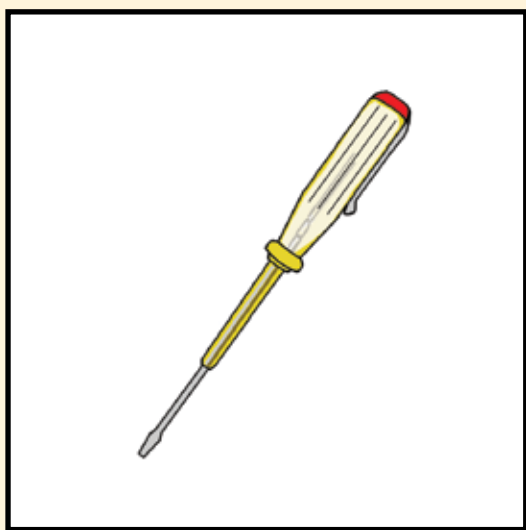

chair

table

almirah

meter

tester

wire



# Accelerated Adult Learning - Basic Literacy

## Lesson 75 Community Health Worker

Read the sentence.



My **sister** is a **health worker**.

sister

health

worker

Name the pictures and match them with the words.

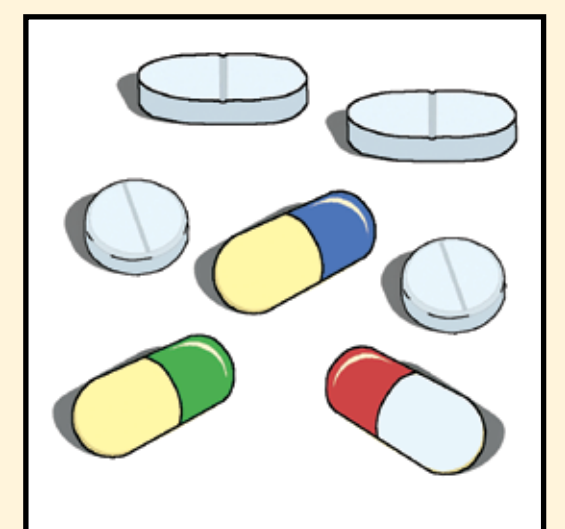
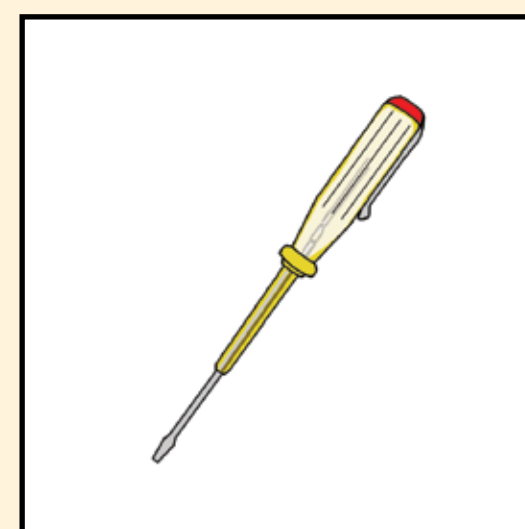
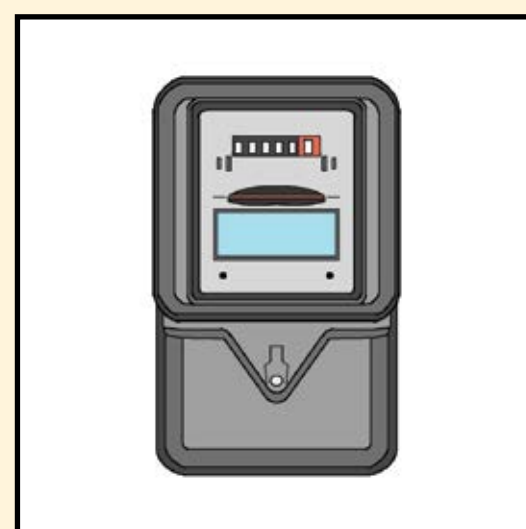
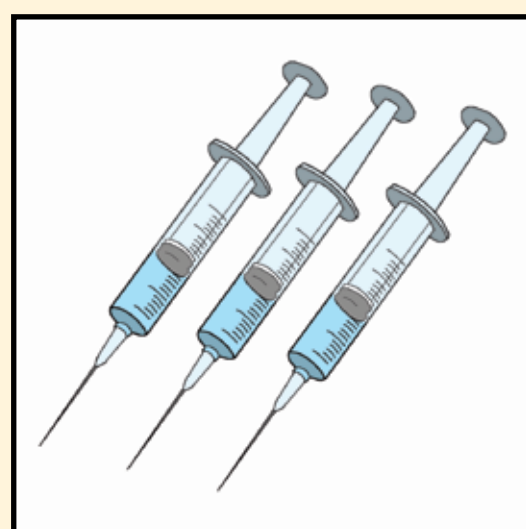
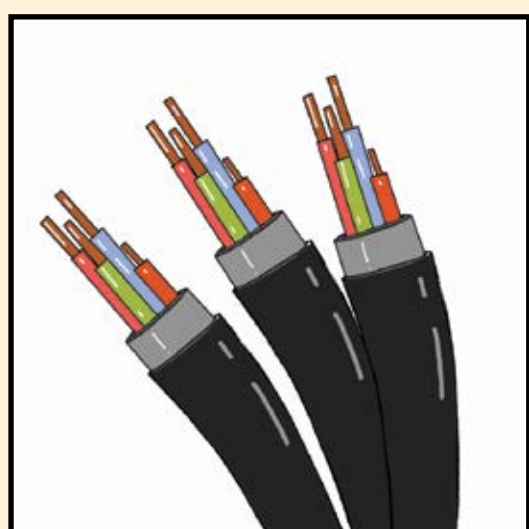

meter

tester

wire

tablet

blood

syringe



# Accelerated Adult Learning - Basic Literacy

## Lesson 76

### Bricklayer

Read the sentence.

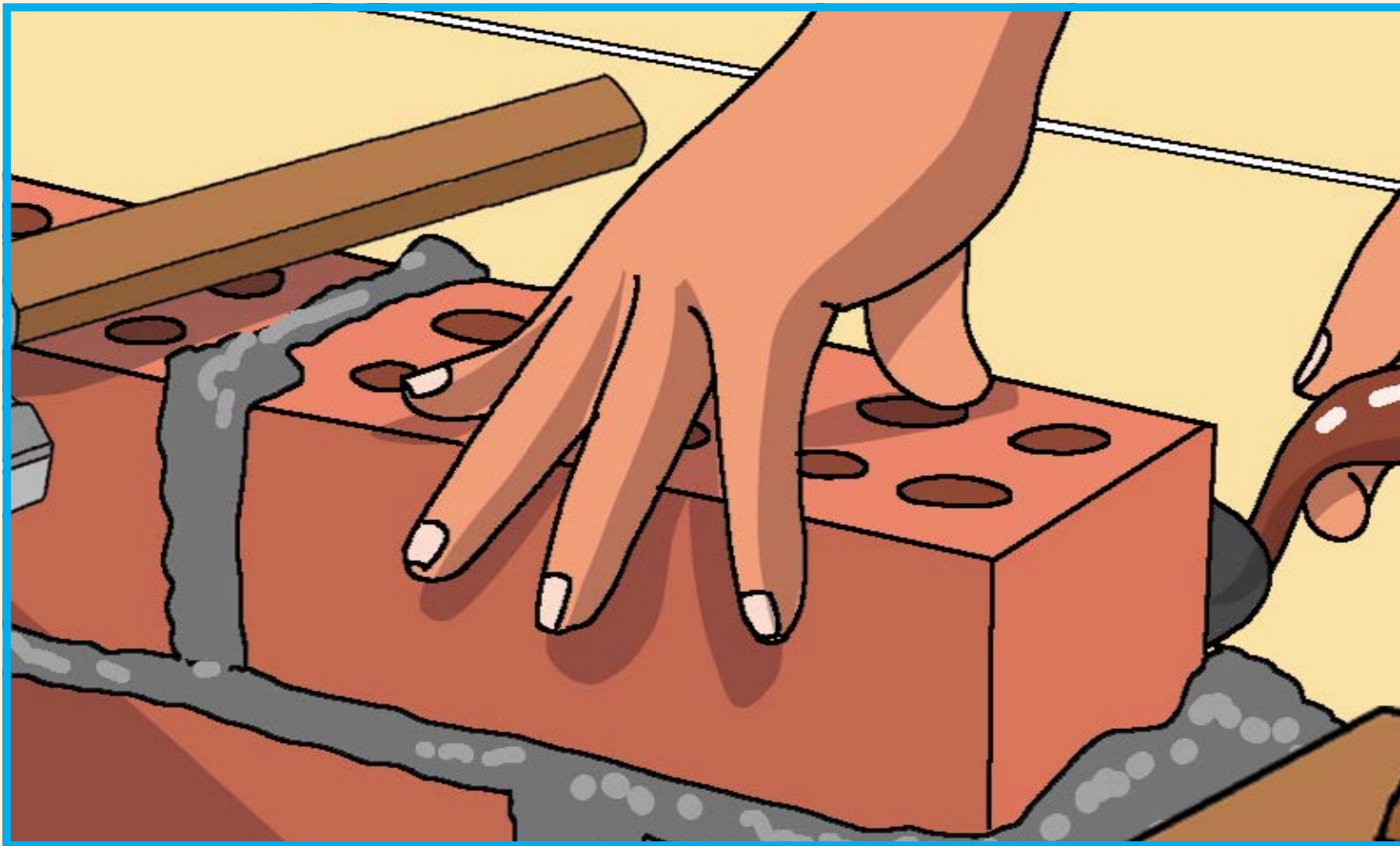

A bricklayer made the walls.

bricklayer

walls

Name the pictures and match them with the words.

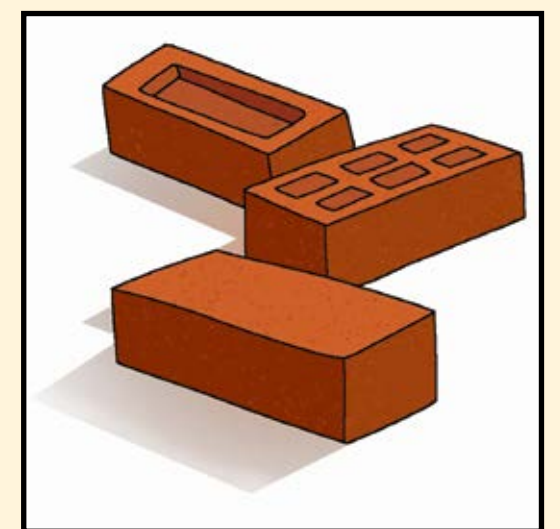
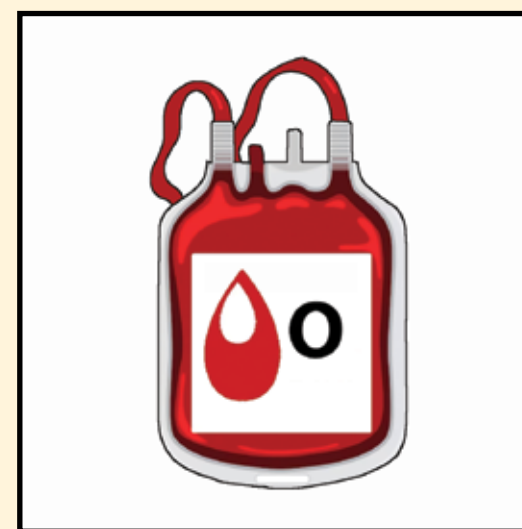
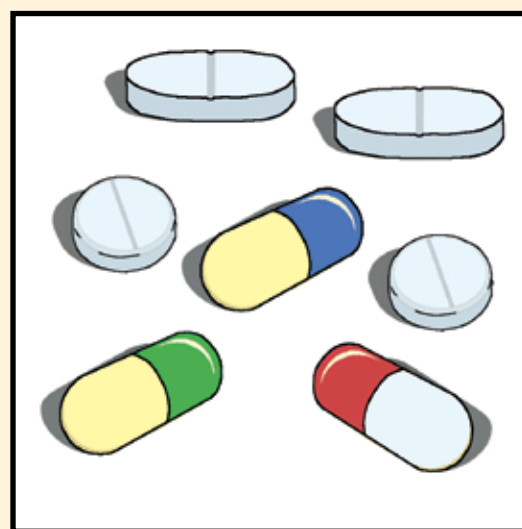
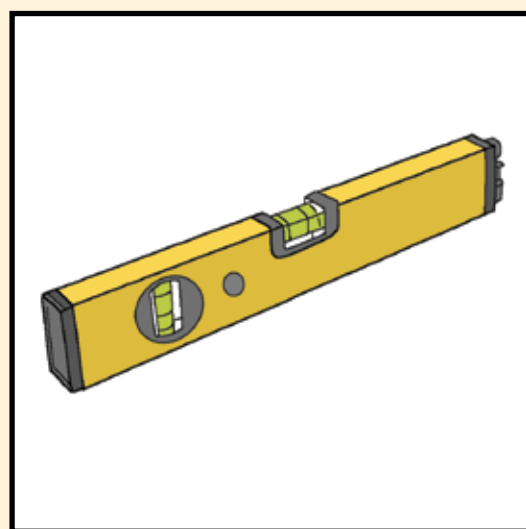
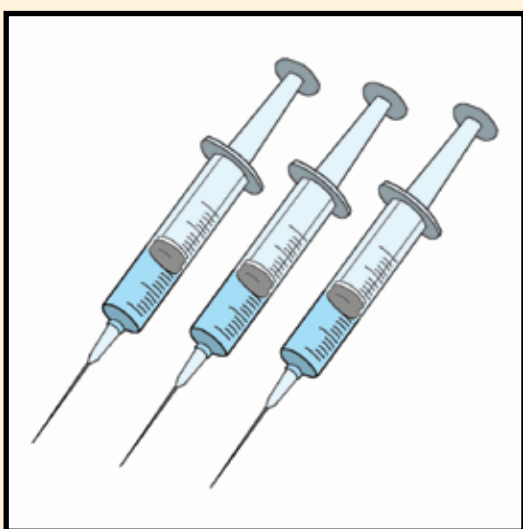

tablet

blood

syringe

brick

cement

level



# Accelerated Adult Learning - Basic Literacy

## Lesson 77 Pipe Repair

Read the sentence.



The **plumber** will **fix** the **leaking** pipe.

plumber

fix

leaking

Name the pictures and match them with the words.

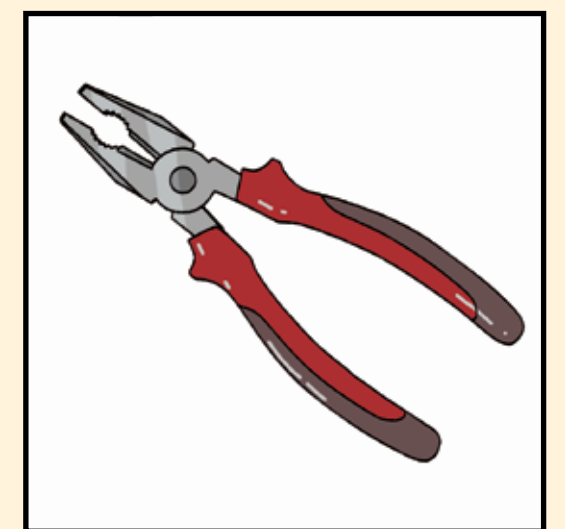
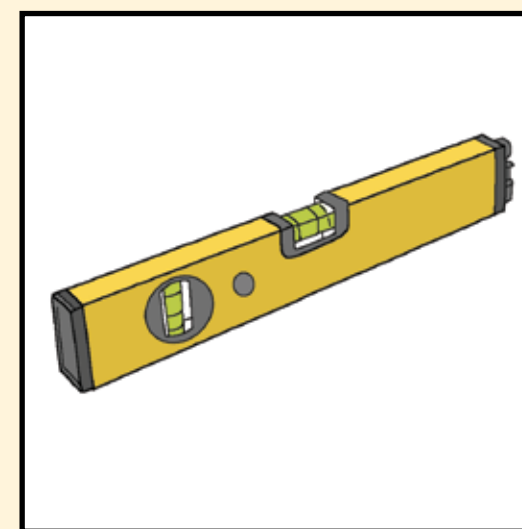
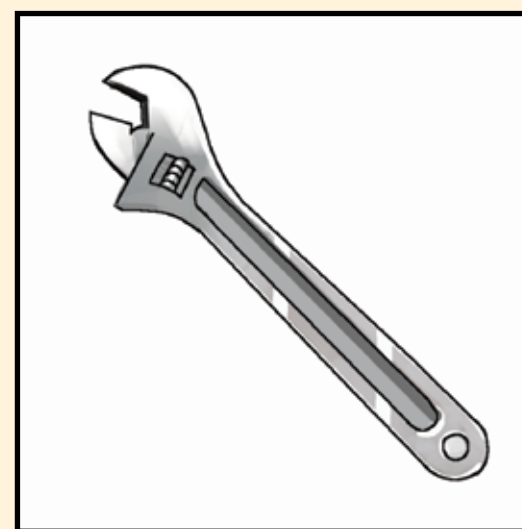
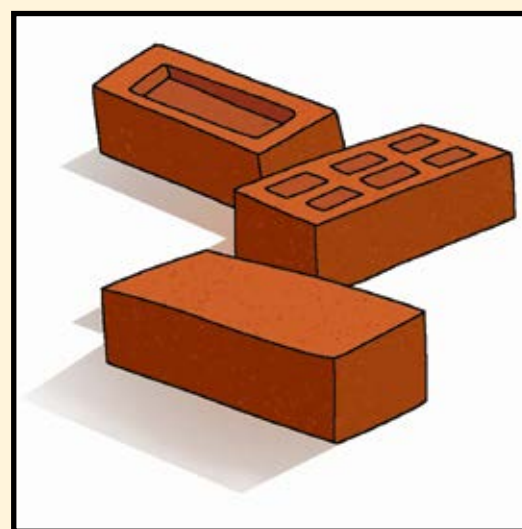
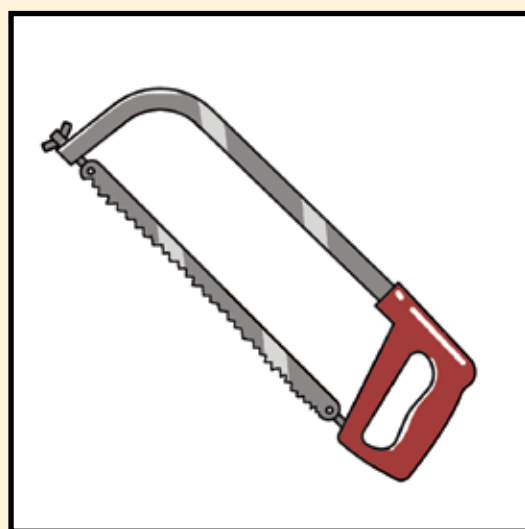

brick

cement

level

hacksaw

pliers

wrench



# Accelerated Adult Learning - Basic Literacy

## Lesson 78 Making Clothes

Read the sentence.



Janu makes **lots** of **different** clothes.

lots

different

clothes

Name the pictures and match them with the words.

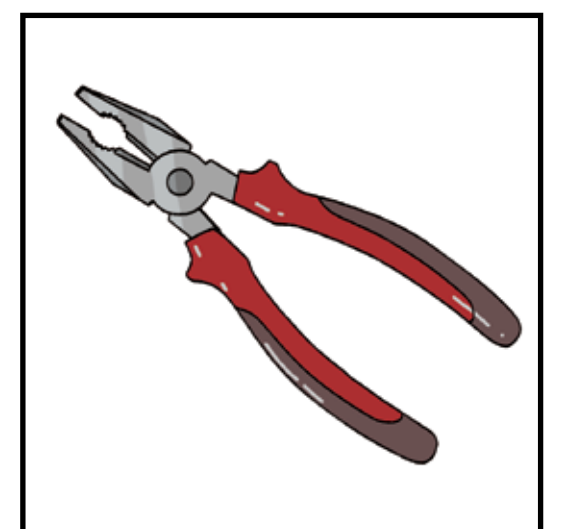
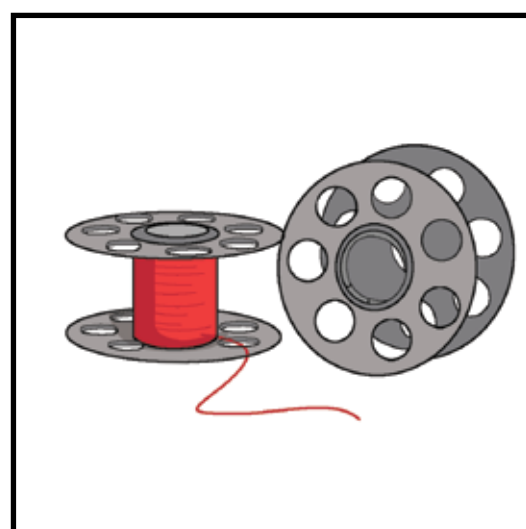
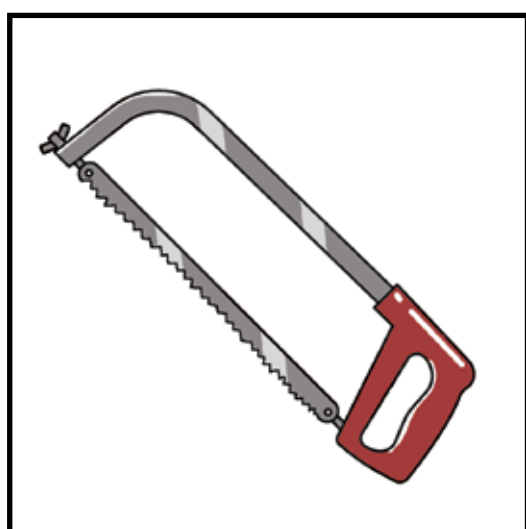
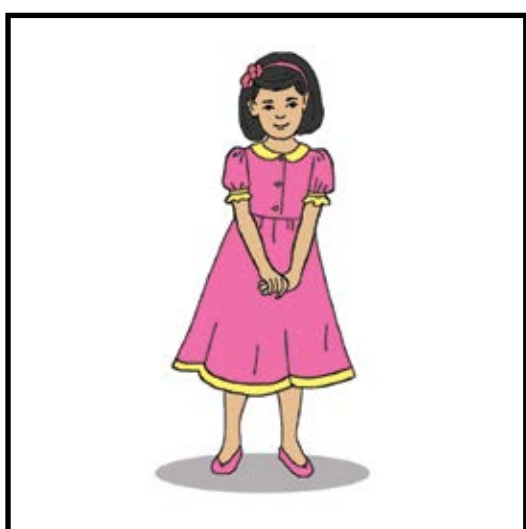
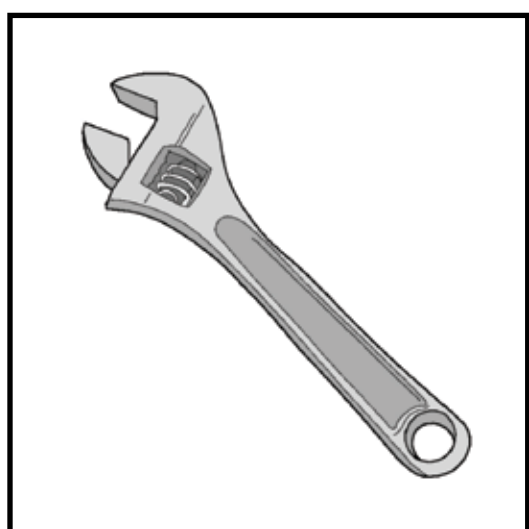

hacksaw

pliers

wrench

frock

bobbin

salwar



# Accelerated Adult Learning - Basic Literacy

## Lesson 79

### Use of Gas Cylinders

Read the sentence.



The use of **gas cylinders** saves **trees**.

gas

cylinders

trees

Name the pictures and match them with the words.

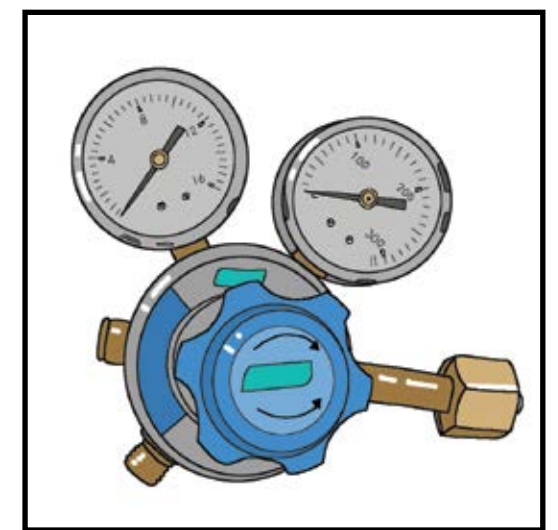
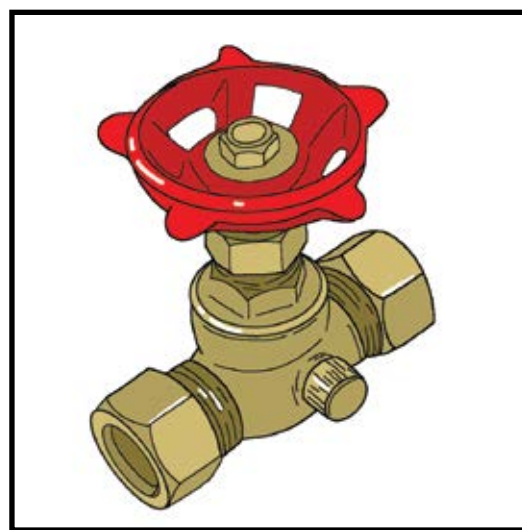
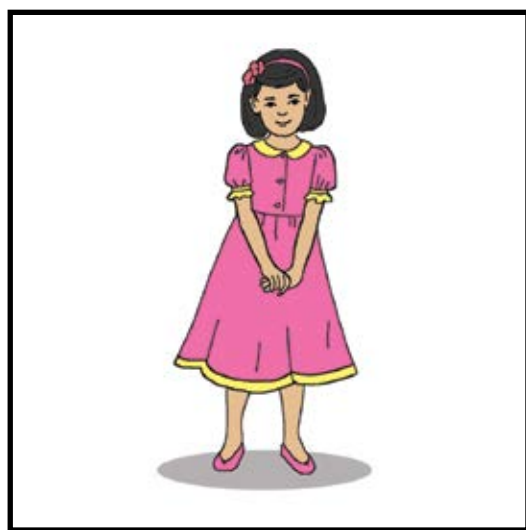
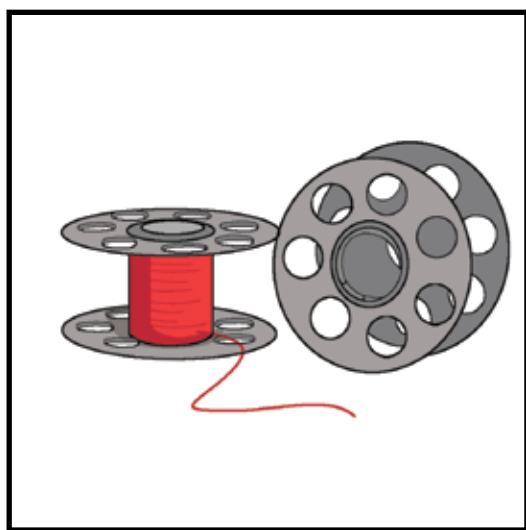

frock

bobbin

salwar

valve

regulator

stove



# Accelerated Adult Learning - Basic Literacy

## Lesson 80

### Review

Read the sentence.



I **sell** **peanuts** in **packets** in the market.

sell

peanuts

packets

Name the pictures and match them with the words.

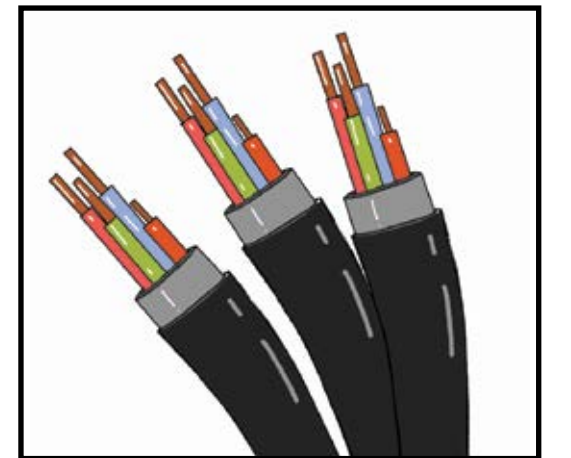
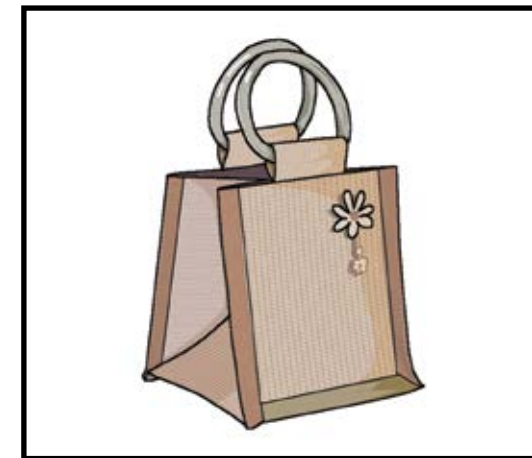

bag

scissors

almirah

wire

blood

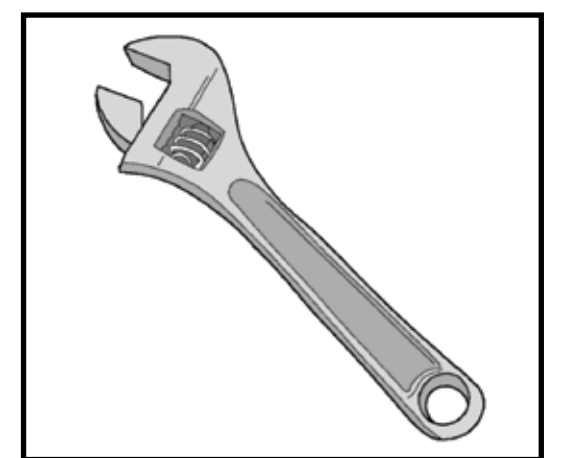
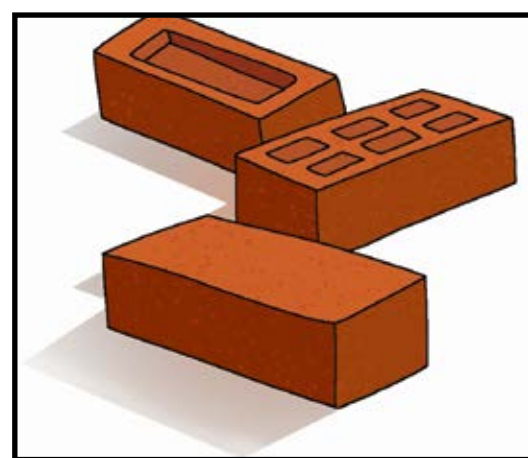
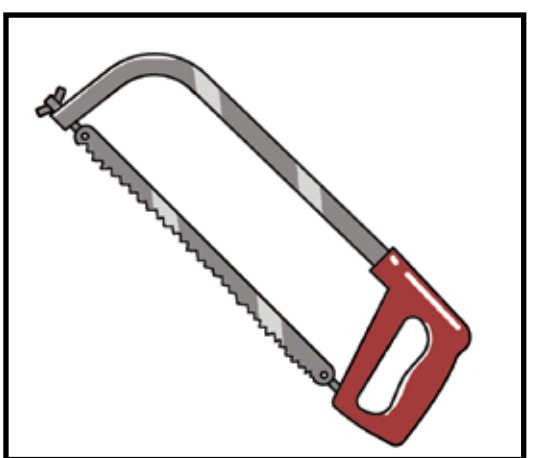

brick

wrench

hacksaw

stove